

INSTRUCTION MANUAL

FOR

INDOOR METAL ENCLOSED SF6  
CIRCUIT BREAKER EQUIPMENT

# YSF6

FOR EQUIPMENT RATED VOLTAGES  
UP TO 13.8KV AND 24KV

The successful operation of all switchgear depends largely upon careful erection, systematic inspection at regular intervals and the maintenance of all parts in a satisfactory condition. If the equipment described in this manual receives the recommended attention it will give many years of reliable and trouble-free service.

Since all designs in the Merlin Gerin range are the subject of continuous research and development work, the equipment supplied may differ in minor details from that described. However, we will be happy to supply on request any additional information which may be required. Please quote the unit serial number(s), the contract number and the date of this manual in any enquiry.

YSF6MAN/JCF/21.06.00  
(front sheet amendment)

DECEMBER 1991 3rd EDITION

SCHNEIDER ELECTRIC LIMITED, THE MEDIUM VOLTAGE DIVISION OF MERLIN GERIN LTD.  
123 Jack Lane, Hunslet, Leeds, LS10 1BS, England.

Telephone: National (0113) 2903500. International +44 113 2903500  
Fax: National (0113) 2903710. International +44 113 2903710  
Web: <http://www.schneider.co.uk>

## CONTENTS

1. "YSF6" CIRCUIT BREAKER UNIT - GENERAL
  - 1.1 Basic Design Concept
  - 1.2 Sulphur Hexafluoride Gas
  - 1.3 "Puffer" Arc Control System
  - 1.4 Operating Mechanism
  - 1.5 Interlocks & Padlocking
  - 1.6 Copperwork & Insulation
  - 1.7 Technical Specification
  
2. DELIVERY & ERECTION
  - 2.1 Typical Minimum Delivery Weights for 630A & 1250A Units
  - 2.2 Loading, Delivery & Unloading
  - 2.3 Storage of Switchgear
  - 2.4 Preparation of Switchroom Floor
  - 2.5 Erection of Fixed Portions
  - 2.6 Fitting the Busbars
  - 2.7 Jointing the Main Cables
  
3. PREPARATION & COMMISSIONING
  - 3.1 Preparation of Fixed Portion
  - 3.2 Preparation of Moving Portion
  - 3.3 Testing of Protective Equipment
  - 3.4 High Voltage Tests
  - 3.5 Making Alive
  
4. MOVING PORTION ISOLATION SYSTEM
  - 4.1 To Plug the Moving Portion into the Fixed Portion
  - 4.2 To Withdraw Moving Portion from the Fixed Portion
  - 4.3 Transfer Earthing of the Circuit Cable
  - 4.4 Earthing the Circuit or Busbars through the Portable Earthing Devices: General
  - 4.5 To Fit the Yellow Earthing Device for Feeder Circuit Earthing
  - 4.6 To Fit the Red Earthing Device for Upper Busbar Earthing
  - 4.7 To Fit the Red Earthing Device for Lower Busbar Earthing
  - 4.8 To Plug in and Withdraw the Moving Portion with either Earthing Device Fitted
  - 4.9 Test Access Device
  
5. OPERATION OF SPRING CLOSING MECHANISMS
  - 5.1 To Charge the Closing Springs Manually
  - 5.2 Electrical Charging of the Closing Springs
  - 5.3 To Close the Circuit Breaker
  - 5.4 To Trip the Circuit Breaker
  - 5.5 Operation of Low Pressure Lock Out System
  
6. INSPECTION, SERVICING AND OVERALL REQUIREMENTS
  - 6.1 General Policy
  - 6.2 Frequency of Maintenance
  - 6.3 Guarantee
  - 6.4 Maintenance Agreements

- 7. INSPECTION & OPERATION CHECKS (5 YEARS/500 OPERATIONS)
  - 7.1 General Inspection
  - 7.2 Operational Check
  - 7.3 Number of Operations
  - 7.4 Gas Pressure
  - 7.5 Isolating Contacts
  - 7.6 Moving Portion Insulation Cleaning
  - 7.7 Insulation Resistance Check
  - 7.8 Visual Inspection of Fixed Portion
  
- 8. SERVICING (10 YEARS/1000 OPERATIONS)
  - 8.1 Inspection and Operation Checks
  - 8.2 Mechanism
  - 8.3 Earth Connections
  - 8.4 Auxiliary Switches & Interlocks
  - 8.5 Isolating & Elevating Mechanisms
  - 8.6 VT & Secondary Circuitry
  
- 9. ADDITIONAL MAINTENANCE OPERATIONS IN EXCEPTIONAL CASES
  - 9.1 Gas Pressure Testing & Filling
  - 9.2 Action in the Event of Low Gas Pressure
  - 9.3 Leakage of SF6 By-products
  - 9.4 Fixed Portion General Overhaul During a Switchboard Outage
  
- 10. SPARES & TOOLS
  - 10.1 Spare Parts
  - 10.2 Tools
  
- 11. KEY TO ILLUSTRATIONS

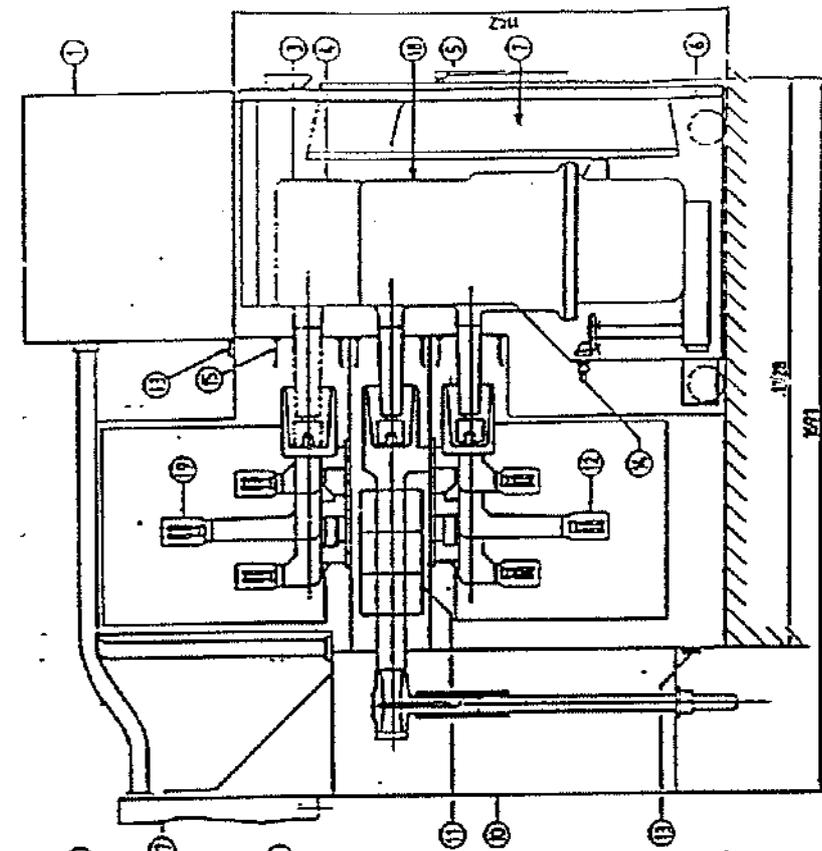

1370  
891  
265 HPR-UM  
1170  
for withdrawal to transfer between busbars

- ① CURRENT TRANSFORMER
- ② LOW LEVEL BUS-BARS
- ③ EARTH CONNECTION
- ④ ELEVATING SCREW HANDLE POSITION
- ⑤ SLITTERS WITH PACKLOCKING FACILITY
- ⑥ TRANSFER EARTH STARTPOINT CONTACT
- ⑦ PLOT CABLE BOX
- ⑧ BREAKER IN LOW LEVEL BUS-BAR POSITION
- ⑨ HIGH LEVEL BUS-BARS

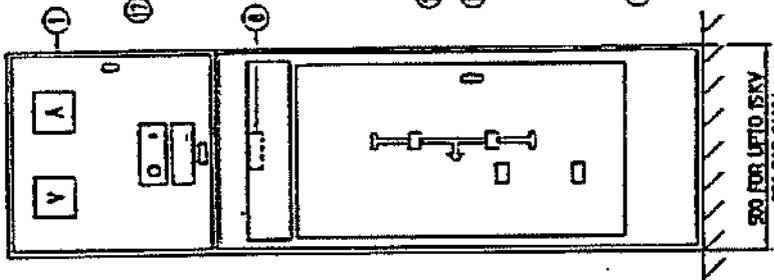

500 FOR LIFTED ISKY  
550 FOR 24KV

- ① RELAY INSTRUMENT PANEL
- ② BREAKER IN TRANSFER EARTH POSITION
- ③ BREAKER IN SERVICE POSITION
- ④ CAST RESIN BREAKER HANDLE FOR REMOVABLE CHARGING STRINGS
- ⑤ REMOVABLE CHARGING STRINGS
- ⑥ MOVING PORTION CARRIAGE
- ⑦ MECHANISM BOX (OPEN/CLOSE)
- ⑧ ISOL IN INTERLOCK
- ⑨ VOLTAGE TRANSFORMER (ISOLATABLE)
- ⑩ ATU INSULATED CABLE BOX

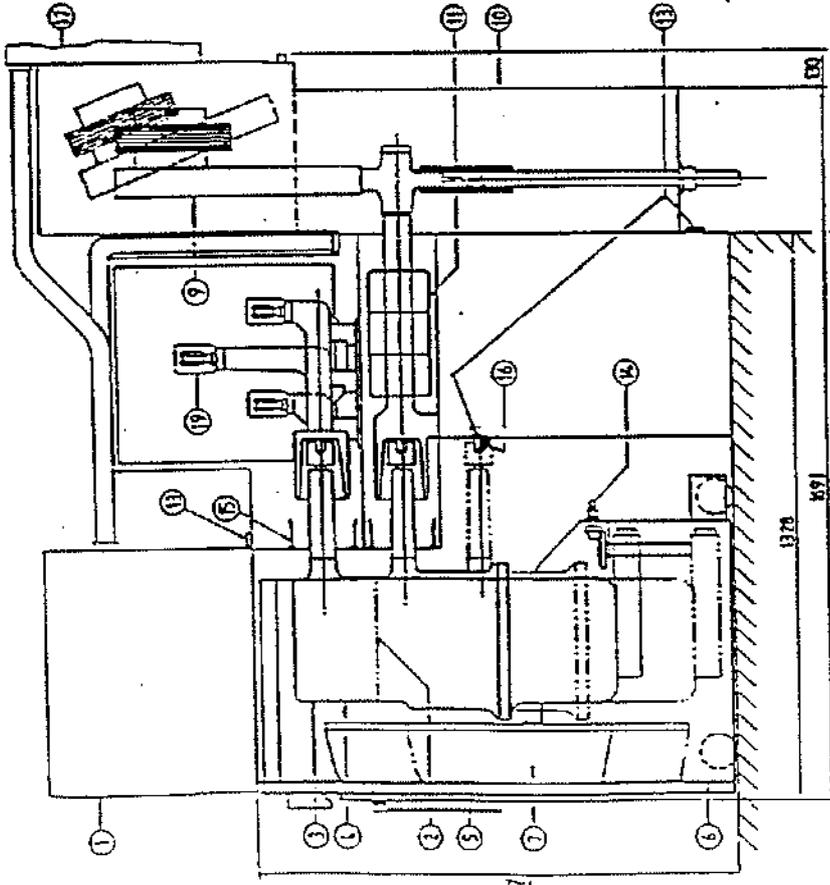

1370  
891  
265 HPR-UM  
1170  
for withdrawal with transfer carriage

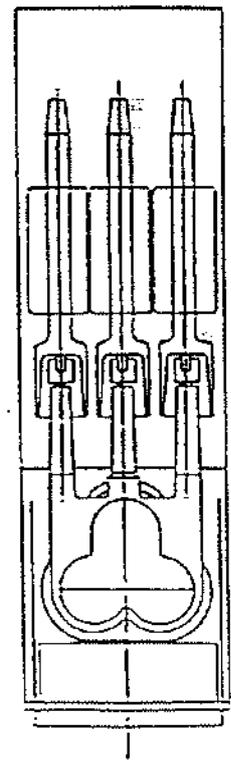

G. A. OF YSF6

## 1. "YSF6" CIRCUIT BREAKER EQUIPMENT - GENERAL

### 1.1 Basic Design Concept

- 1.11 "YSF6" is the designation of a range of indoor, metal enclosed, sulphur hexafluoride (SF6) circuit breaker equipment for service at a range of voltages up to 24kV and symmetrical breaking current fault levels up to 40kA. See sub-section 1.7, "Technical Specification", in this manual.
- 1.12 Each individual fixed portion and moving portion has a data plate giving its own various ratings, which must not be exceeded without prior approval from Merlin Gerin MV Division.
- 1.13 The insulation and arc control systems are designed and certified for use on 3 phase, 50/60Hz systems with earthed neutral. "YSF6" units must not be used on other types of system without prior approval from Merlin Gerin MV Division.
- 1.14 Each panel has two major components:-
- a) The horizontally isolatable moving portion, a wheeled carriage (6) carrying the cast resin moulding (4) which houses the three, single phase arc control systems, the operating mechanism (7), the moving main isolating contacts (41), front panel (42) and door (43); and
  - b) The fixed portion housing.
- 1.15 The fixed portion housing is a rigid, sheet steel structure incorporating the busbars (12 & 19) in a chamber or chambers, cable box (10), fixed main isolating contacts (44), transfer earthing contacts (16) where fitted, voltage transformer (9) where fitted, current transformers (11) and instrument and relay accommodation (1). The modular design of the fixed portion enables a variety of alternative arrangements to be produced.
- 1.16 In the standard unit, a single set of busbars (19) is mounted in a chamber above the current transformer (11) chamber. Beneath the current transformer chamber are three fixed star-point contacts (16) which are bonded to the switchboard metalwork earth. To earth the feeder circuit (10), the circuit breaker moving portion is withdrawn from the switchboard and the circuit breaker module is wound down from the upper (3) to the lower (2) location by means of a detachable handle (56) which is fitted to a spigot (14) at the rear of the moving portion. When the moving portion is plugged into the fixed portion, the lower moving isolating contacts (41b) engage the star point contacts (16) and the upper ones (41a) engage the feeder fixed isolating contacts (44a). Busbar earthing is by means of a portable earthing device (55) which mounts on the moving portion main isolating contacts (41).
- 1.17 Where a duplicate set of busbars (12) is required, an additional low-level busbar chamber is incorporated below the current transformer (11) accommodation. Its fixed main isolating contacts (44b) are in the position occupied on transfer earthing equipped units by the earth star point contacts. The elevating feature of the moving portion (56, 14) is used in this instance to transfer the circuit breaker module, and thus the feeder circuit, between the upper and lower sets of busbars. Variants of the portable earthing device (55) permit earthing of the feeder or either set of busbars.
- 1.18 In some cases, because of the fault levels involved or to suit customers' operating requirements, busbar and feeder earthing trucks may be provided. These are essentially fully rated circuit breaker moving portions which connect a single, 3 phase set of isolating contacts to a star point earthing connection.

# Modular Design Flexibility (1.1A)

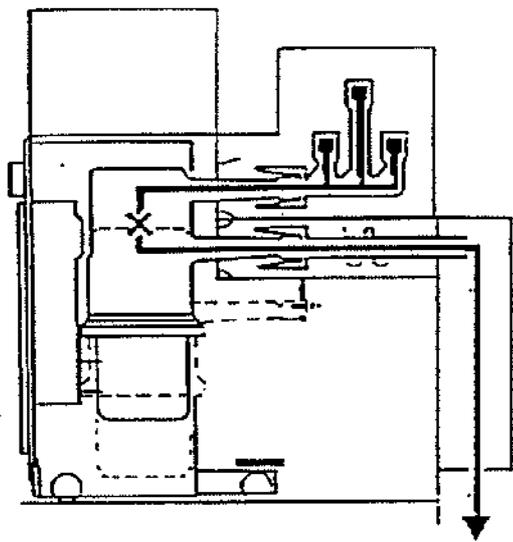

1

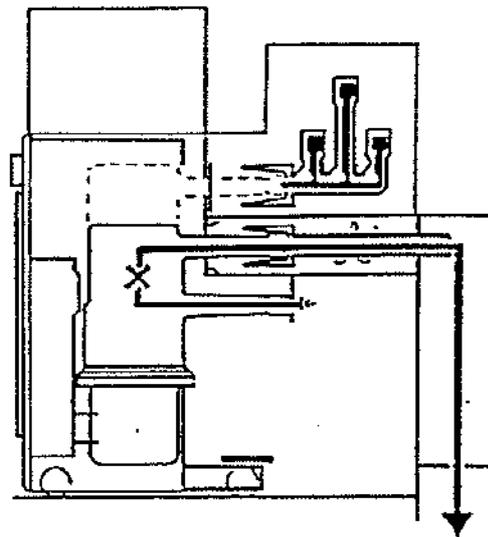

2

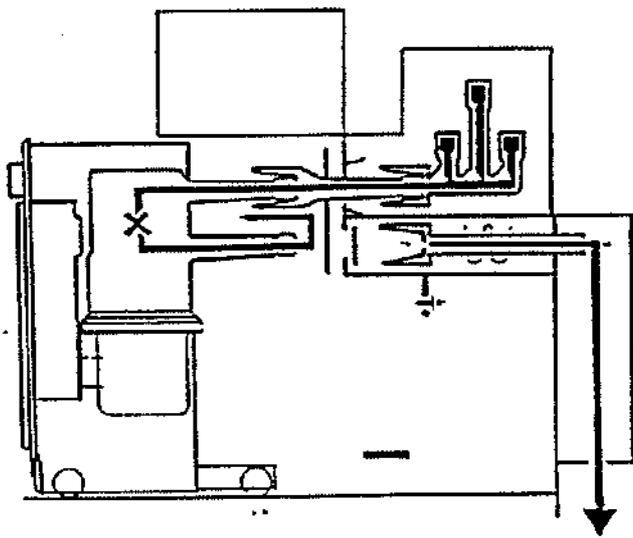

3

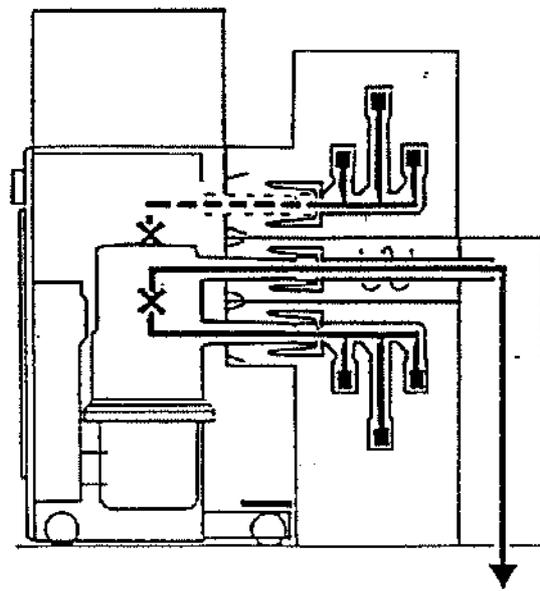

4

- 1 The standard single busbar design has the busbars in the high level position preferred by most utility engineers.
- 2 Lowering the circuit breaker module, plugging the moving portion in and closing the breaker earths the feeder circuit.
- 3 A portable, one-piece device which mounts on the moving portion provides an economical means of earthing the busbars.
- 4 Switchboards can be supplied with a duplicate set of busbars, selected by the vertical transfer of the circuit breaker module. Feeder or busbar earthing is by means of the device in (3).

1.19 Isolation of the circuit breaker is always by its horizontal withdrawal from the fixed portion. In order to permit an adequate spring pressure to be applied to the moving main isolating contact clusters (41), so ensuring a good electrical connection with the fixed contacts (44), their actual mating and separation is by means of a horizontal screw (62) which engages with a flexibly mounted nut (72) on the fixed portion. The screw is operated through the winding handle (56) which is plugged into a socket on the end of the screw through a hole in the front panel (42). The screw only operates over the few centimetres involved in the actual mating and separation of the contacts. Secondary circuits are made and broken simultaneously by means of fixed (84) and moving (85) secondary isolating contact blocks.

## 1.2 Sulphur Hexafluoride Gas

1.21 Sulphur hexafluoride (SF<sub>6</sub>) is, at normal ambient temperatures, a colourless, odourless, non-toxic, non-flammable gas. It does not occur naturally, but must be artificially synthesised. It remains gaseous down to a temperature of -60°C at 760 Torr (mm Hg). Because the sulphur atom is in its highest valency state, with six co-valent bonds with fluorine atoms, the molecule is extremely stable and chemically inert.

1.22 SF<sub>6</sub> is a heavy gas, approximately five times as dense as air. Its thermal conductivity is only 42% that of air, but it has a high specific heat, peaking at the temperature (around 2100-2500°K) at which the molecule dissociates and re-forms. The result is that, in a circuit breaker, the gas is uniquely able to transfer vast amounts of heat away from the arc, to cool the arc and lessen the possibility of re-strikes after current zero.

1.23 SF<sub>6</sub> has a high dielectric strength; at 0.9 bar it coincides with that of switch oil. It is also electro-negative, and readily "mops-up" free electrons, as well as creating a positive space charge around an electrode, thus further raising the breakdown voltage.

1.24 Pure SF<sub>6</sub> is non-toxic: manufacturers of SF<sub>6</sub> gas perform routine batch tests by placing mice in an 80/20% SF<sub>6</sub>/air atmosphere for 24 hours. They are unharmed. There is a theoretical possibility of asphyxiation if SF<sub>6</sub> gas collects in a low lying part of a switchroom but, in practice, the volume of gas employed in YSF<sub>6</sub> breakers is so small that, even if all the gas leaked from a unit, the resulting "pool" of gas would be only a few millimetres deep.

1.25 At high temperatures (above 800°C) and when exposed to electric arcing, SF<sub>6</sub> breaks-down into sulphur and fluorine atoms, most of which re-combine on cooling to re-form SF<sub>6</sub>. Small quantities of decomposition products may also be formed, but these are absorbed by a molecular sieve filterpack of activated alumina and soda lime in the base of the circuit breaker drive housing. Since the unit is sealed for life, the filterpack has adequate capacity for the whole of the unit's operating life.

1.26 In sum, sulphur hexafluoride is an ideal arc-quenching medium for use in circuit breakers; approximately 100 times more effective than air. It has been used for many years at transmission voltages and for some years at distribution levels. The "YSF<sub>6</sub>" unit has been developed in the light of this operational experience.

## 1.3 "Puffer" Arc Control System

1.31 The principle of operation of the "YSF<sub>6</sub>" circuit breaker is a variation on the "dual flow single puffer" system (Figs 1.3A, B, C, D). The moving contact system incorporates a piston (25a) which compresses a specific volume of gas and then blasts it axially along the arc. This eliminates the need for an external compressor or gas reservoir, avoids the risk of ingress of moisture and reduces the number of potential leak points. In fact, the design of the circuit breaker is such that the number of gas/air seals is at a minimum: one (34) at the junction of the cast resin chamber (4, 21) and the metal drive linkage housing (35), one at the point at which the mechanism drive shaft (37) enters the linkage housing, and the seals in the filling valve and its attendant pressure measuring equipment. Note, that all of these seals are above the level of the filterpack.

- 1.32 Since the nominal gas pressure within the chamber is always within the range 0.6 bar to 1.5 bar above atmospheric (according to rating - see data plate on front of moving portion) the risk of significant leakage is minimal. The breaker has been shown to interrupt fault current with the internal pressure deliberately allowed to drop to atmospheric. However, see paragraph 1.78.
- 1.33 The illustrations show the construction and operation of a single phase of the circuit breaker. All three phases are housed in chambers within the monobloc cast resin enclosure (4, 21), and these chambers all open into a single metal drive linkage housing (35) so that there is a single gas envelope.
- 1.34 With the circuit breaker closed (Fig 1.3A), there are two parallel circuits between the upper (22) and lower (30) isolating contact bushing conductors. The main circuit is via the sprung fixed main contact fingers (23), the contact face of the compressor piston (25b) and the main conductor rod (29); in parallel with the main contact fingers is the upper arcing electrode (27), which is pushed by spring pressure firmly into a butt contact with the lower arcing electrode (28), the thickened and tipped section at the top of the main conductor rod (29).
- 1.35 When the breaker is tripped (Fig 1.3B), the drive shaft (37) rotates to pull down the linkage (36, 33) and thus the conductor rod (29) and piston (25a). The main contact between the piston face (25b) and fixed contact fingers (23) is broken, and the whole of the load or fault current now flows through the arcing electrodes (27, 28) which remain in contact as the upper electrode (27) is pushed down by its throw-off spring to follow the movement of the lower electrode (28). This arrangement ensures that there is no significant arcing or erosion at the main contacts, so that the overall closed contact resistance of the circuit breaker will remain virtually constant throughout its life. The downwards movement of the piston (25a) compresses the SF6 gas in the space between it and the partition (31).
- 1.36 Next the upper arcing electrode (27) reaches the limit of its travel and stops. The lower electrode (28) continues to move, and an arc is drawn between them (Fig 1.3C). The separation of the contacts leaves clear the gas ports through the piston (25a) and nozzle (24), and cool SF6 gas, under pressure due to the continuing movement of the piston, flows around and along the arc (which does not usually occupy the full circumference of the electrodes). The gas cools the outer layer of the arc plasma, strips off electrons and constricts the arc, before passing up and down the two hollow conductor rods, carrying heat away from the arc and dissipating it in the relatively large gas volumes in the top of the arcing chamber and in the drive linkage housing.
- 1.37 In the case of a heavy fault current, the volume of the arc may be such that it occupies the entire circumference of the electrodes (27, 28) and so blocks the flow of cool gas from the ports in the nozzle (24). This is known as "clogging" or "corking". The result is that the gas pressure continues to build up beneath the piston until, with the approach of current zero, the arc decreases sufficiently for the gas to blast through under the increased pressure, to ensure extinction and prevent re-striking after current zero. This self regulating feature is one of the major advantages of the "single puffer" system.
- 1.38 Whether the breaker operates in the free-flowing or the "clogging" mode, the electro-negative nature and remarkable heat transfer capability of the gas result in rapid de-ionisation of the plasma, the dissociated ions rapidly recombining to form stable molecules of SF6. Any remaining traces of arcing products are deposited on the absorbent surfaces of the filter pack (38) in the base of the drive linkage housing (35) during the natural diffusion and circulation of the gas. Actual arc extinction occurs at or near current zero, so that dangerous overvoltages due to either current chopping or pre-arcing are not created.
- 1.39 At the end of the opening stroke, the piston (25a) comes to rest with a full 65mm clearance between the arcing electrodes (27, 28), the space being filled with SF6 gas as an insulant. When the breaker is subsequently re-closed (Fig 1.3D), the decompressive effect of the rising piston opens spring loaded flap valves (20) to draw clean, cool gas from the lower chamber of the enclosure, ready for the next opening operation.



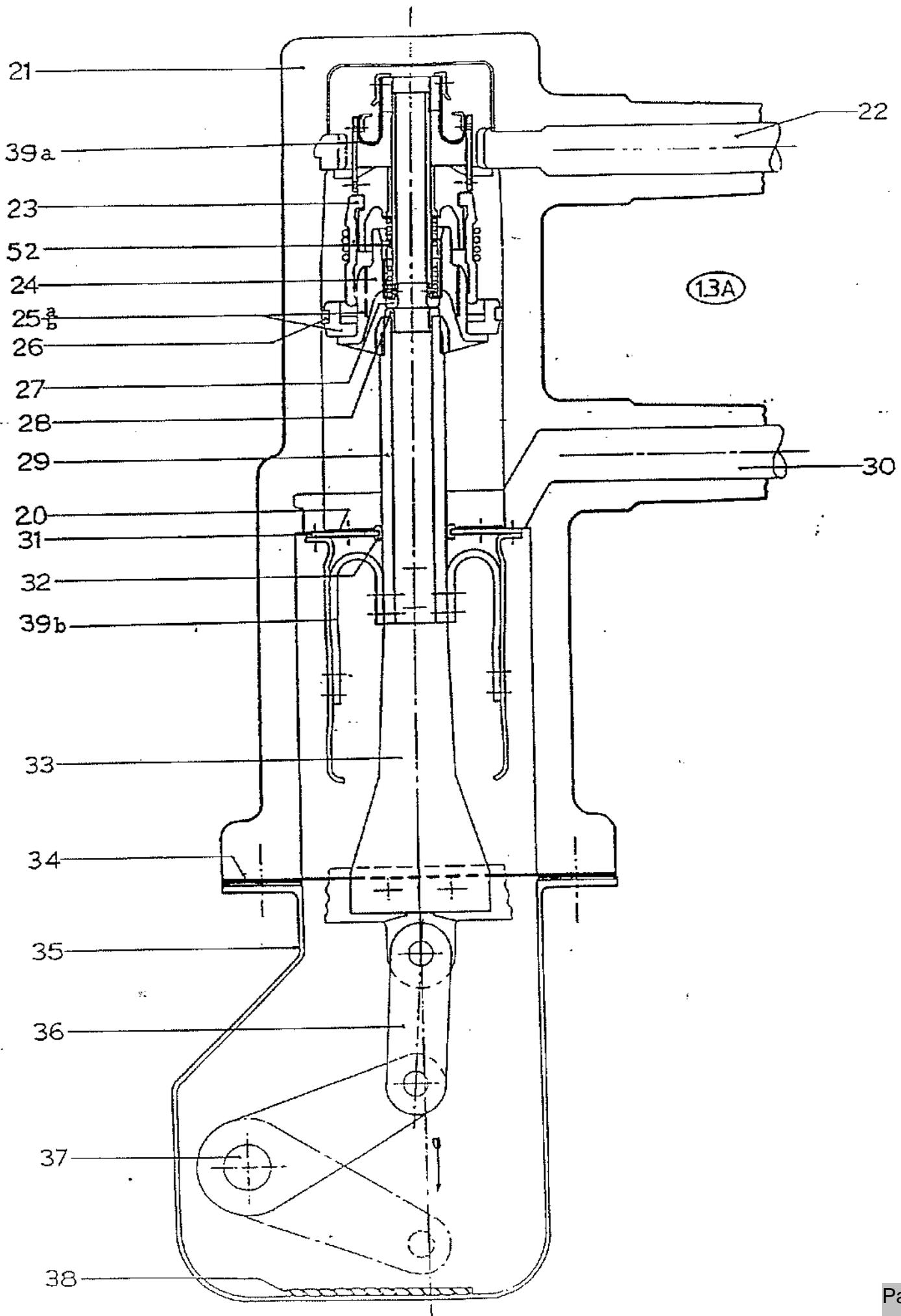

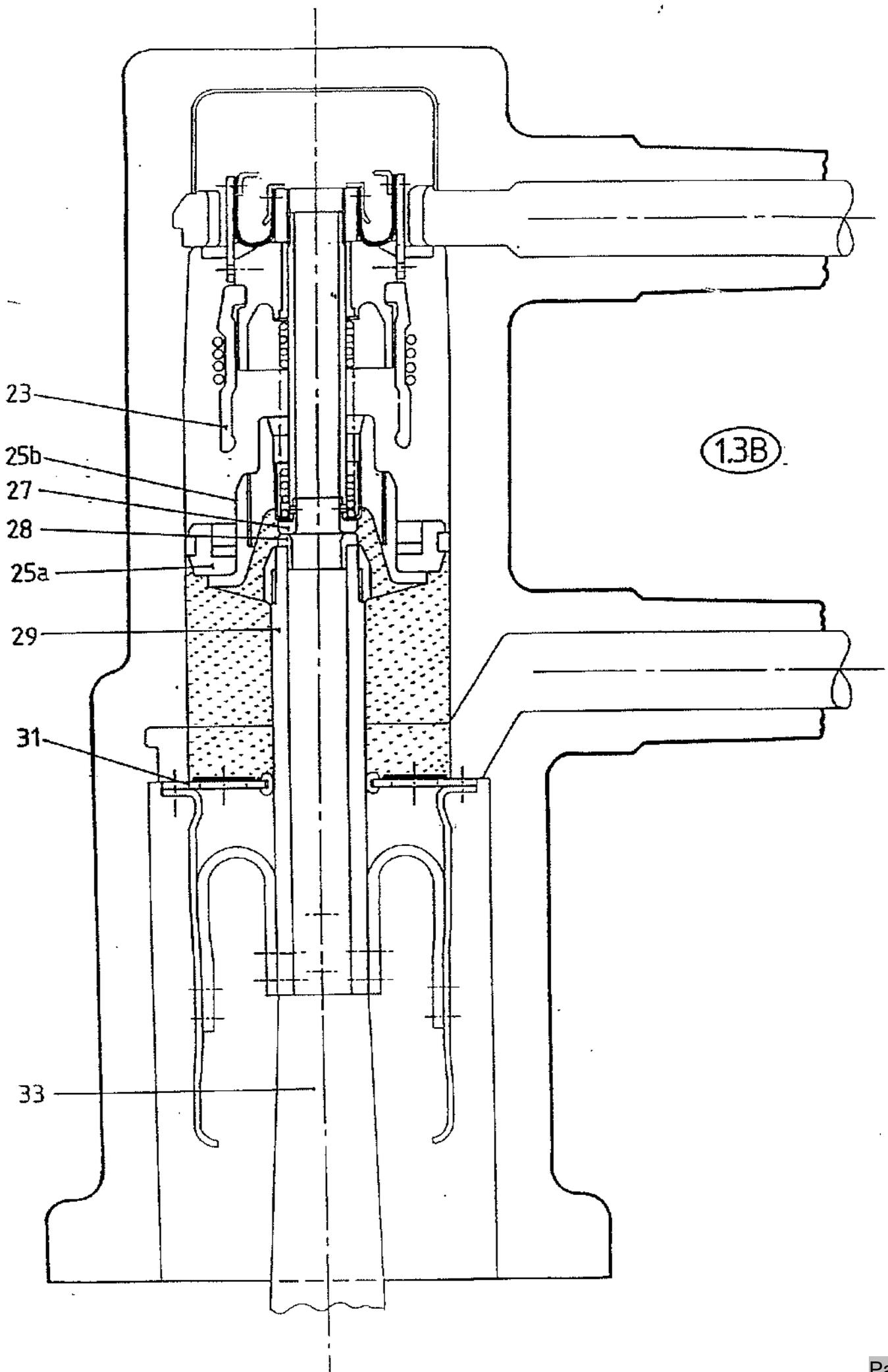

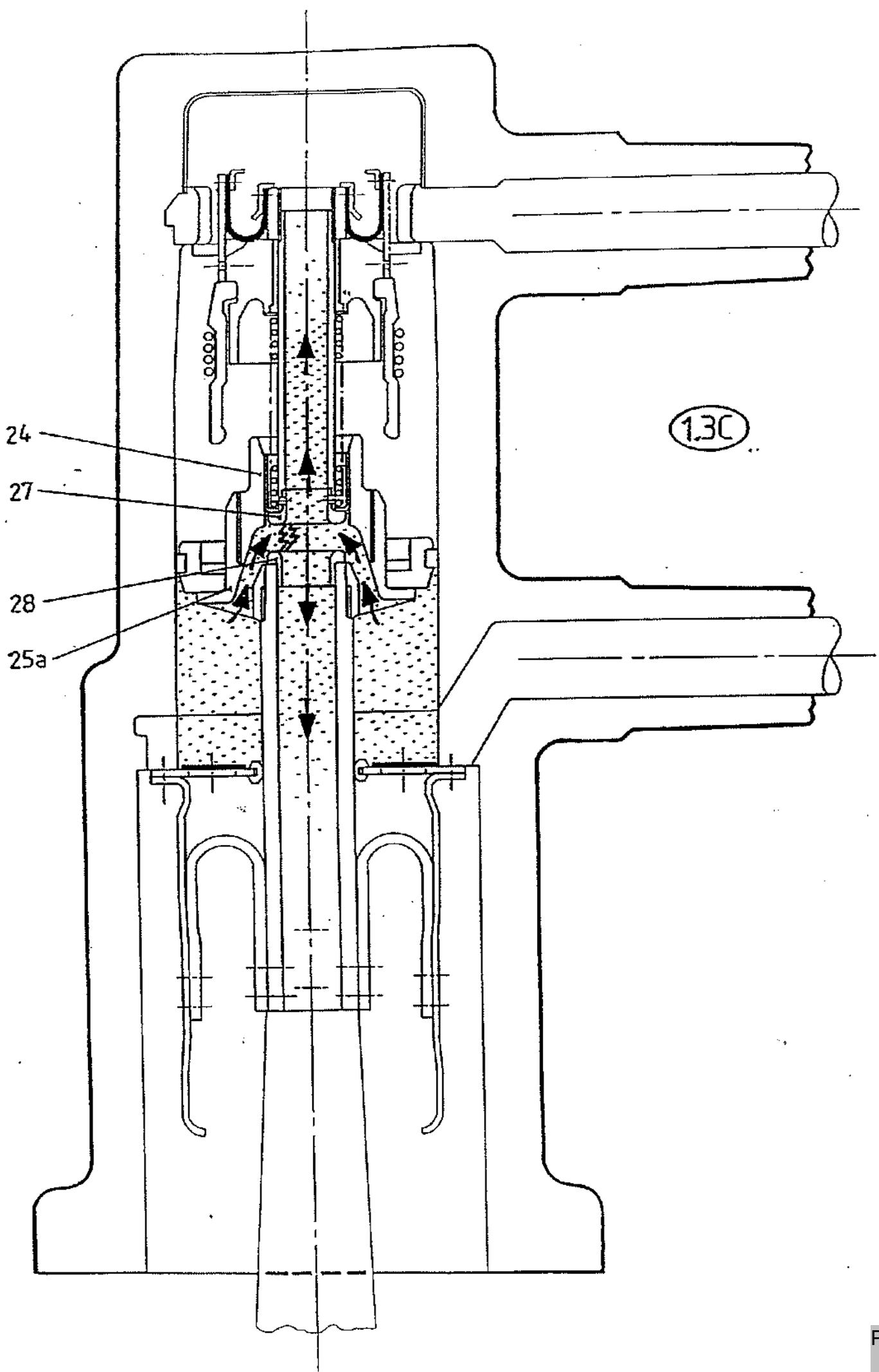

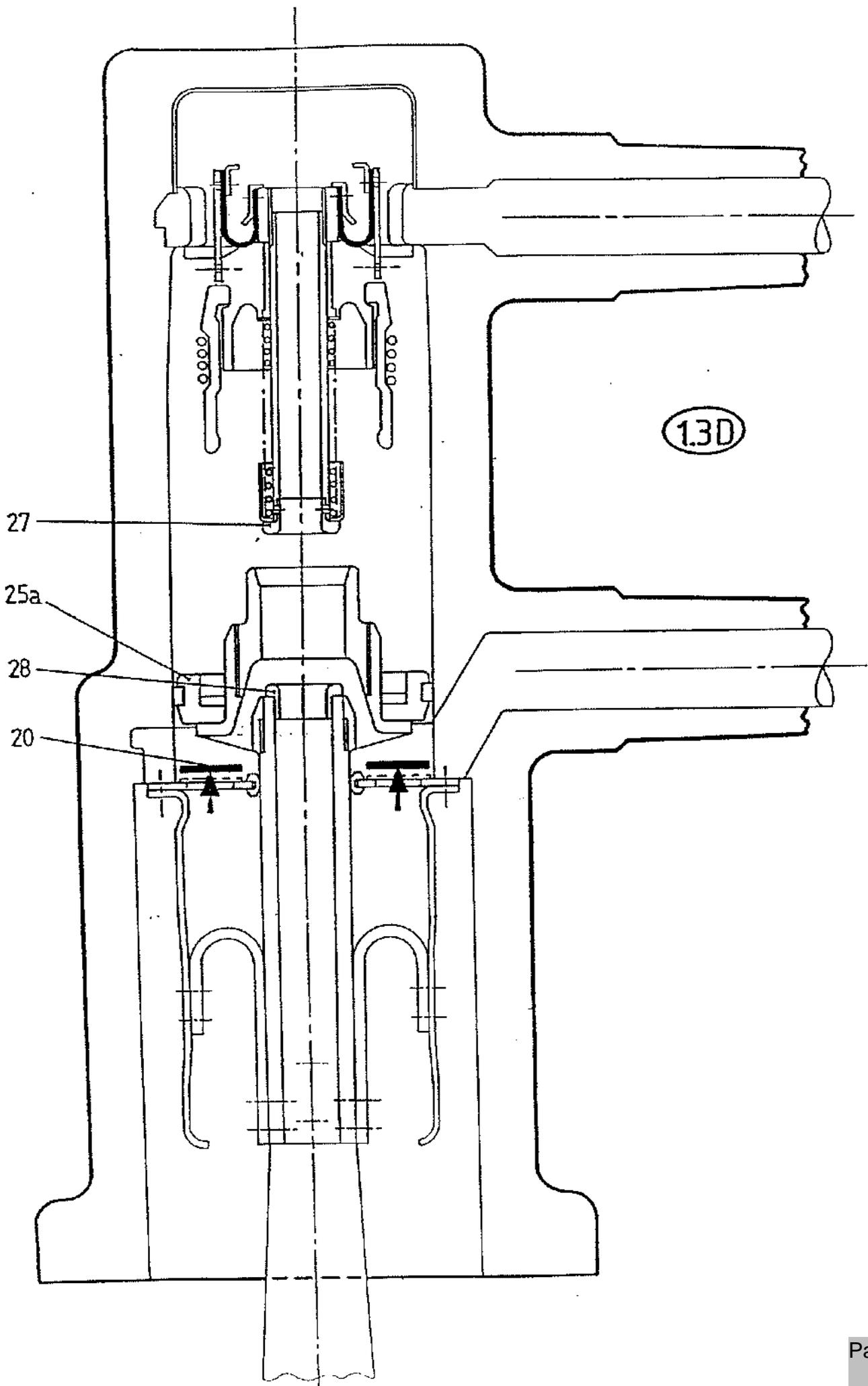

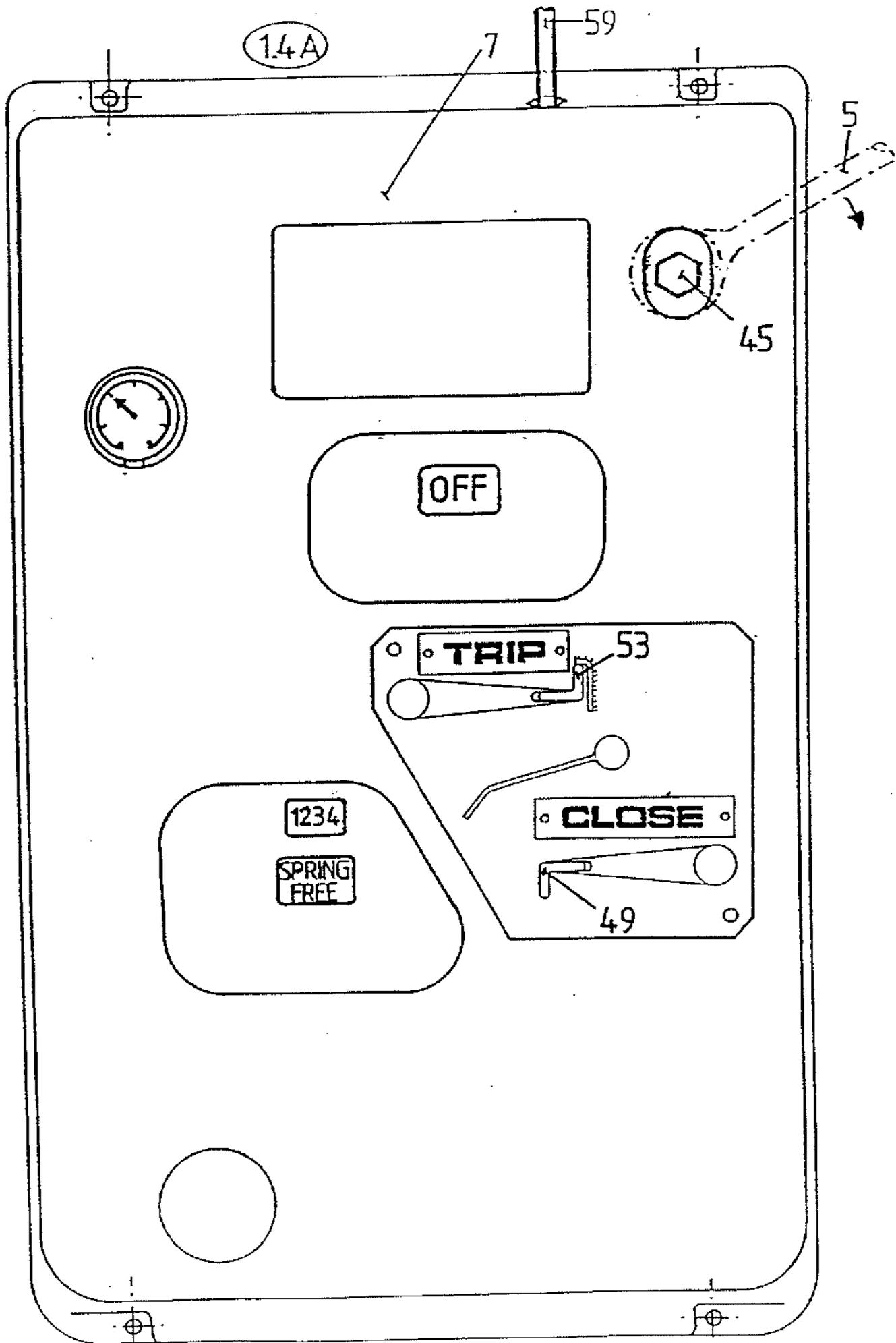

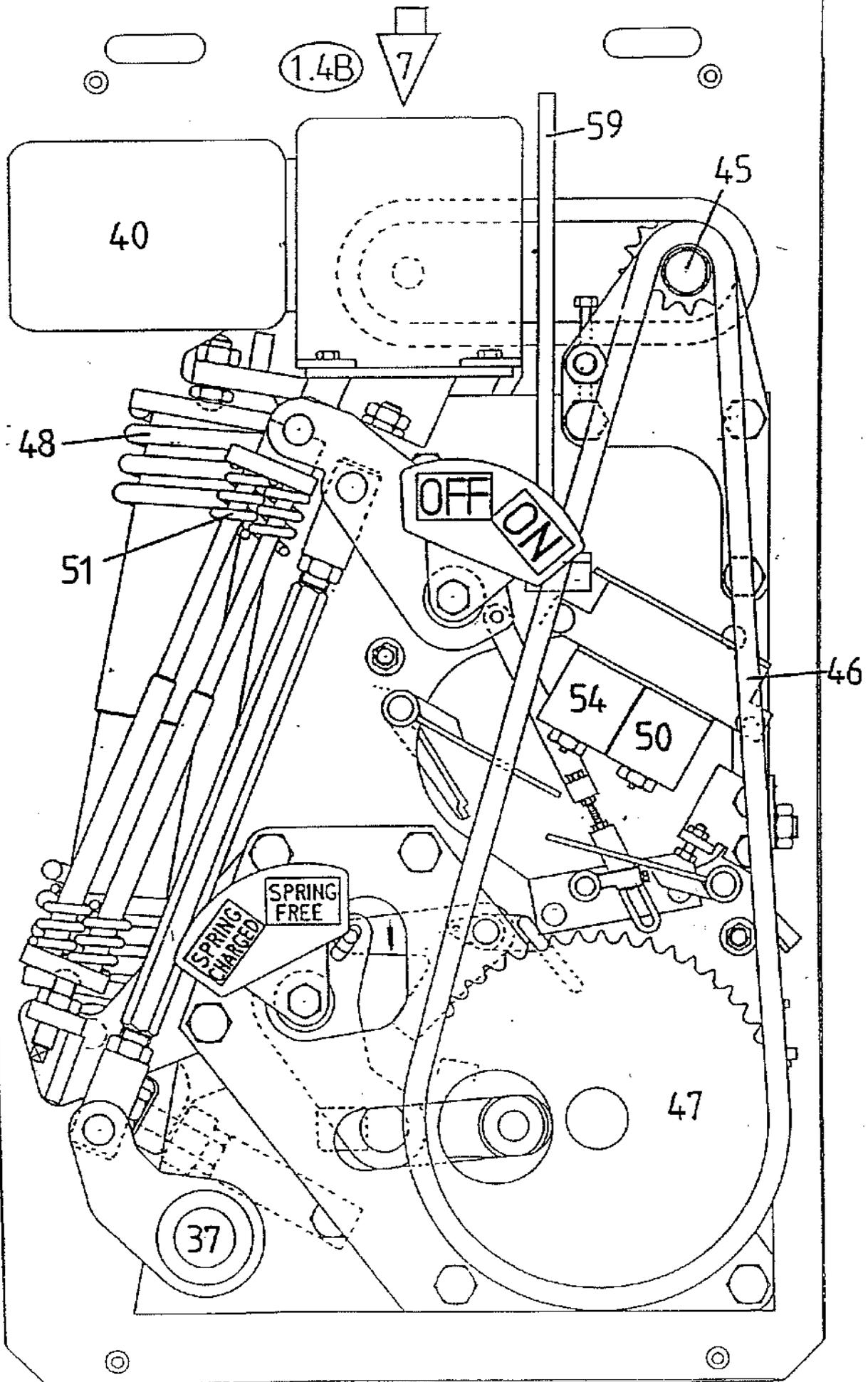

#### 1.4 Operating Mechanism

- 1.41 The "YSF6" unit is fitted with a spring closing mechanism (7) (Fig 1.4A, B). This may be charged by hand, using a ratchet type charging handle (5), or by means of a spring charging motor (40) which drives onto the same sprocket as the hand charging handle spigot (45). Where a unit is equipped with a spring charging motor, the hand charging facility is retained for use if the auxiliary supply should be lost.
- 1.42 A unit is originally supplied equipped for hand charging only can be readily retro-fitted with a charging motor and associated control equipment, since the standard wiring loom includes the necessary connections.
- 1.43 The drive from the charging handle or motor is transferred, through a chain (46) and a ratchet wheel (47), to a lever system which compresses the closing spring (48).
- 1.44 When the "CLOSE" lever (49) on the front of the mechanism housing (7) is pressed, or the "CLOSE" coil (50) is energised, the spring pressure is released to drive round the shaft (37) and push the linkage (36) and drive link (33) upwards, so pushing the three piston/moving contact assemblies (25, 28 etc.) into engagement with the fixed contacts (23, 27 etc.) (Fig 1.3A).
- 1.45 At the same time, the opening springs (51) and upper electrode springs (52) are compressed, ready if need be for immediate re-opening. Should the breaker be tripped during the closing stroke, it will complete the closing movement and then immediately re-open. This ensures that the full swept volume of gas is available beneath the piston to guarantee a rapid, clean break.
- 1.46 When the circuit breaker is closed, a second charge may be stored on the closing spring to allow for immediate reclosure if required after a trip operation. Breakers with motor charged spring mechanisms may be wired up so that this operation is automatic once the "auto/off" or "auto/non-auto" switch is set to "auto".
- 1.47 The breaker may be tripped by means of a mechanical trip lever (53) adjacent to the "CLOSE" lever, or by means of the trip coil (54) which may be energised by the manual operation of a trip/close lever on the control panel or by the operation of automatic protective circuitry.

#### 1.5 Interlocks & Padlocking

- 1.51 Positive interlocks incorporated in the design prevent potentially dangerous mal-operation of the equipment (Fig 1.5A). Any circuit breaker can be locked to prevent closure when it is open. Any circuit breaker can be locked to prevent manual tripping, while still permitting electrical tripping, when it is closed, but see paragraph 1.56 below.
- 1.52 A moving portion cannot be plugged into or withdrawn from a fixed portion unless the circuit breaker is OFF. The position of the mechanism, and thus of the contact system, is conveyed via a telescopic drive rod (59) to the auxiliary switch drive fork (58a) which is at the front of the moving portion top plate (60) behind the front panel (42). The drive fork has an interlock lug (61) which, when the fork is in the ON position, obstructs a lug (116) on the isolating selector rod (63) so that the selector (8), rod (63) and hold in blocks (64) are held in the SERVICE position. The block (64) engages with the hold-in bracket (65) on the underside of the fixed portion top plate, to prevent the moving portion being plugged in or withdrawn. An auxiliary linkage from the front fork (58a) to a repeater fork (58b) further back on the top plate ensures that the appropriate remote indication will still be given when the moving portion is in the TEST position i.e. isolated from the fixed main contacts but still partly within the housing and with the selector (8), rod (63) and hold-in blocks (64) in the SERVICE position.

1.5A

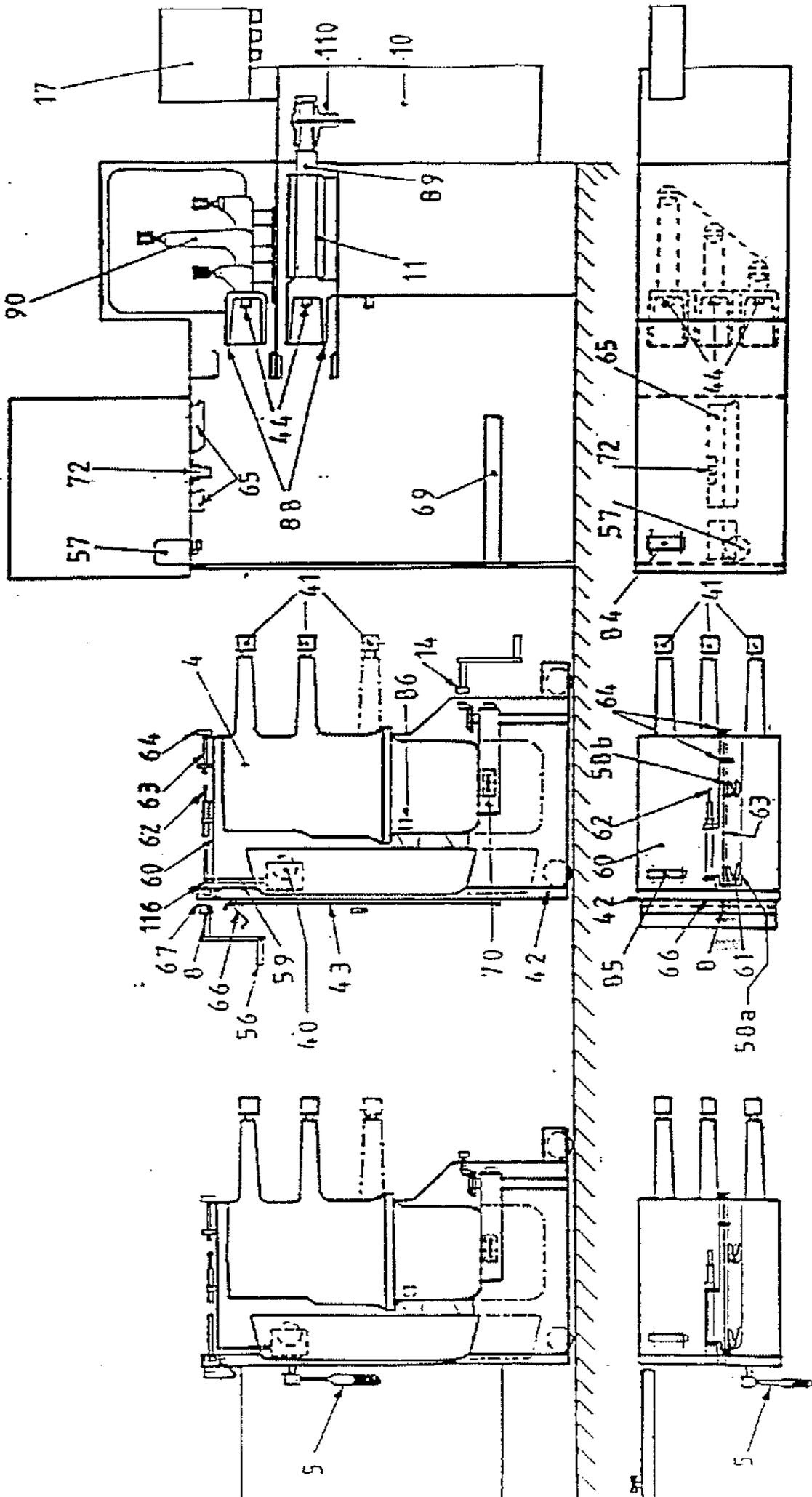



- 1.53 A circuit breaker cannot be closed to ON unless it is correctly located horizontally, i.e. fully plugged in, located at the test/isolate position within the housing, or fully withdrawn from the fixed portion. At any intermediate position, the hold-in bracket (65) prevents the hold-in block (64) and thus the isolating selector (8) being moved to the SERVICE position. In any other position, the isolating selector (8) prevents the interlock flap (66) being raised from the position at which it prevents the moving portion front panel door (43) being opened to give access to the mechanical CLOSE lever (49). In addition, an interlock cam (67) on the selector rod (63) depresses an isolating switch (68) to cut off the supply to the close coil (50) and charging motor (40) (where fitted), when the selector is in any position other than SERVICE.
- 1.54 A moving portion which is anywhere between its elevated and lowered positions cannot be pushed into the fixed portion. An interlock lug (70) on the right hand side of the moving portion is spring-loaded to protrude and catch against the front edge of the fixed portion side sheet. With the moving portion in the fully elevated or lowered position, this lug can be pushed back against the spring pressure by the fixed portion front edge and the rubbing strip (69) behind it. With the moving portion in any intermediate vertical position, however, the lug cannot pivot back and so the moving portion is prevented from entering the fixed portion.
- 1.55 A moving portion cannot be wound up or down unless it is fully withdrawn from the fixed portion housing. Only then is it possible to reach the elevating screw handle location (14) to fit the winding handle (56).
- 1.56 Where a switchboard is equipped for transfer earthing of the feeders, each moving portion is equipped with a micro-switch so located and wired that when the circuit breaker is lowered to the transfer earth position, the electrical trip circuit is isolated, so that the earth, once applied, can only be removed manually by someone on the spot. The padlocking points mean that the authorised person concerned can ensure that only he or she can do this.
- 1.57 The trip lever/button, close lever/button, isolating selector, feeder shutters and busbar shutters all have padlock points. Electrical control levers such as TRIP/CLOSE, AUTO/OFF and ON/OFF switches can also be supplied with padlocking facilities. DO NOT attempt to press the TRIP lever (53) and CLOSE lever (49) at the same time as damage to the mechanism could result.

NOTE: When the close lever (49) is padlocked to prevent operation, any attempt to close the breaker by local or remote electrical control could result in burning out the close coil (50).

- 1.58 The circuit breaker module is equipped with a low-pressure switch (86), which is wired to a relay in the fixed portion. If the internal gas pressure falls below a pre-set level, the switch will operate. The relay can be used to operate local or remote alarms or indications and can be arranged to disconnect the trip and close circuits or to trip the breaker immediately, according to the customer's requirements. In addition, and at extra cost, a visible pressure gauge can be provided. (See section 5.5).
- 1.59 The safety shutters (15) can be padlocked closed: see paragraph 3.12.

## 1.6 Copperwork & Insulation

- 1.61 A major factor in the design of the YSF6 unit is the use of a sophisticated cast resin insulation system, which enables a 125kV impulse level (for 24kV operation) to be incorporated in a unit no bigger than many current 12kV equipments. At the heart of the design is the complex monobloc moulding (4, 21) which houses the three contact systems and carries the moving main isolating contacts (41).
- 1.62 The isolating contacts (41) engage fixed contacts (44) which are deeply shrouded in cast resin receptacle insulators (88).
- 1.63 In the case of the feeder circuit, these are three separate mouldings, extended at the rear to form bar primary bushings (89) for the current transformers (11) and tapered at the end in the cable box (10) to accept the disconnectable cable connection.

1.64 The busbar receptable insulators form part of a 3 phase moulding (90) incorporating three post insulators, which support the busbars. The busbar tee off connections have shrouds (91) which can be filled with a cold pouring silicon compound (for 125kV impulse level) or left empty (for 95kV impulse level).

1.7 **Technical Specification**

1.71 YSF6 circuit breaker units conform to the following standard specifications, among others:-

BS.358, BS.923-1, BS.4828, BS.5311, BS.6480, BS.6581;  
IEC.52, IEC.56, IEC.60-1, IEC.270, IEC.298, IEC.694;  
ESI.41-5, ESI.41-18, ESI.41-26 (draft).

Insulation (see paragraph 1.84)  
rated for systems up to:

15kV (75/95kV impulse level) at 500mm centres.

24kV (125kV impulse level) at 550mm centres.

Rated frequency:

50-60Hz

Busbar normal current ratings:

1250A, 2000/2300A

Circuit breaker normal current ratings:

630/1250A at 500mm crs.  
1250A at 550mm crs.

2000/2300A at 947mm crs.  
(see separate manual)

1.72 Fault current ratings.

Voltage (kV)	Load Current (A)	Symmetrical Breaking Current (kA)	Making Current (kA Peak)	Impulse Voltage (kV)	* Filling Gas Pressure (Bar Gauge)	3 Second Short Time Current (kA)
24	2000/2300	25	62.5	125	1.9	25
24	1250	25	62.5	125	1.0	25
13.8	1250	20	50	95	0.6	20
13.8	630	20	50	95	0.6	20
12	2000/2300	40	100	95	2.5	40
12	2000/2300	31.5	79	95	1.9	31.5
12	2000	25	62.5	95	1.5	25
12	1250	40	100	95	2.5	40
12	1250	31.5	79	95	1.5	31.5
12	1250	25	62.5	95	1.0	25
12	1250	20	50	95	0.6	20
12	630	20	50	75	0.6	20

\* = Gas pressure measured at 20°C (68°F) ambient temperature. Gauge readings may differ slightly between units due to variation in gas pressure. Separate alarm and lockout pressure are optionally available.

Refer to pressure/temperature graphs 1.9A, B, C, D, E & F.

- 1.73 Opening time, from application of tripping voltage to instant of separation of arcing contacts, is less than 40m sec. Total break time, from application of tripping voltage to instant of final arc extinction, is of the order of 50m sec.
- 1.74 Other ratings may become available later - please ask for details.
- 1.75 Variations in pressure will occur due to variations in temperature. When checking pressure use data plate graph (located on front panel below the door).
- 1.76 First check with aid of thermometer ambient temperature (°C). Then from temperature scale on graph read off corresponding pressure (KPa).
- 1.77 If the pressure gauge reading is low compared with the graph reading then the circuit breaker will require topping up with gas. (See section 7.4 & 9.1 to 9.2).
- 1.78 The following list of diagrams; 1.7A, 1.7B, 1.7C, 1.7D & 1.7E are typical examples of data plates. These examples are for reference only and the data label on the breaker should be referred to as details vary from customer to customer.



**YORKSHIRE  
SWITCHGEAR**  
LEEDS LS6 2BN ENGLAND

**YSF6**

CONFORMS TO BS.5227, BS.5311, IEC.56

SERIAL No

RATED VOLTAGE 13.8 kV

RATED IMPULSE WITHSTAND VOLTAGE 95 kV

RATED FREQUENCY 50/60 Hz

RATED NORMAL CURRENT 1250 A

RATED SHORT CIRCUIT BREAK CURRENT 20 kA

RATED DURATION OF SHORT CIRCUIT 3 SEC

MASS 250 kg

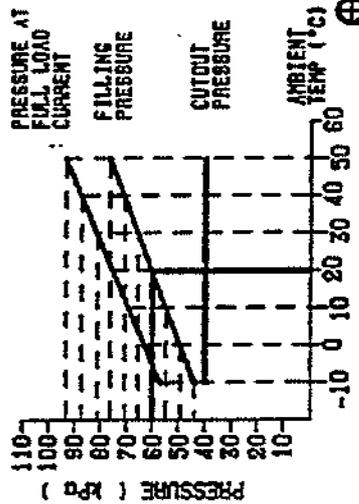

1.7 A

YSF6 60KPa 0.6BAR 20KA "PUFFER"



**YORKSHIRE  
SWITCHGEAR**  
LEEDS LS6 28N ENGLAND

**YSFG6**

CONFORMS TO BS.5227, BS.5311, IEC.56  
 SERIAL No \_\_\_\_\_  
 RATED VOLTAGE 12 KV  
 RATED IMPULSE WITHSTAND VOLTAGE 95 KV  
 RATED FREQUENCY 50/60 Hz  
 RATED NORMAL CURRENT 1250 A  
 RATED SHORT CIRCUIT BREAK CURRENT 25 KA  
 RATED DURATION OF SHORT CIRCUIT 3 SEC  
 MASS 250 kg

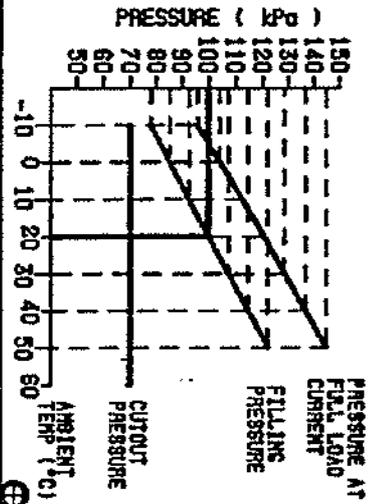

1.7 B

YSFG 100KPa 1.0BAR 25KA "PUFFER"



**YORKSHIRE SWITCHGEAR**  
LEEDS LS6 2BN ENGLAND

**YSF6**

CONFORMS TO : BS.5227, BS.5311, IEC.56  
 SERIAL No   
 RATED VOLTAGE 12 kV  
 RATED IMPULSE WITHSTAND VOLTAGE 95 kV  
 RATED FREQUENCY 50/60 Hz  
 RATED NORMAL CURRENT 1250 A  
 RATED SHORT CIRCUIT BREAK CURRENT 31.5 KA  
 RATED DURATION OF SHORT CIRCUIT 3 SEC  
 MASS 250 kg

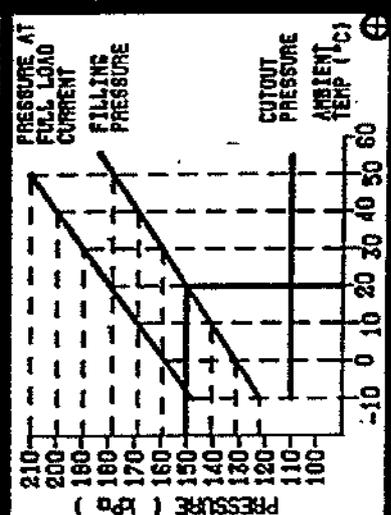

1.7 C

YSF6 150KPa 1.5BAR 31.5KA "PUFFER"



**YORKSHIRE SWITCHGEAR**  
LEEDS LS6 2BN ENGLAND

**YSFG**

CONFORMS TO BS.5227, BS.5311, IEC.56  
 SERIAL No   
 RATED VOLTAGE 12 KV  
 RATED IMPULSE WITHSTAND VOLTAGE 95 KV  
 RATED FREQUENCY 50/60 HZ  
 RATED NORMAL CURRENT 2000/2300 A  
 RATED SHORT CIRCUIT BREAK CURRENT 31.5 KA  
 RATED DURATION OF SHORT CIRCUIT 3 SEC  
 MASS 250 kg

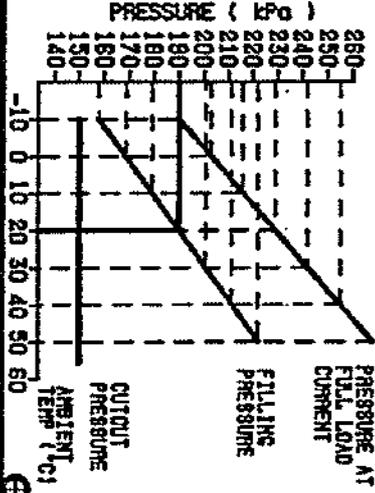

1.7 D

YSFG 190KPa 1.9BAR 31.5KA "PUFFER"



**YORKSHIRE  
SWITCHGEAR**  
LEEDS LS6 2BN ENGLAND

**YSF6**

CONFORMS TO : BS.5227, BS.5311, IEC.56

SERIAL No.

RATED VOLTAGE 12 kV

RATED IMPULSE WITHSTAND VOLTAGE 95 kV

RATED FREQUENCY 50/60 Hz

RATED NORMAL CURRENT 2000/2300 A

RATED SHORT CIRCUIT BREAK CURRENT 40 kA

RATED DURATION OF SHORT CIRCUIT 3 SEC

MASS 250 kg

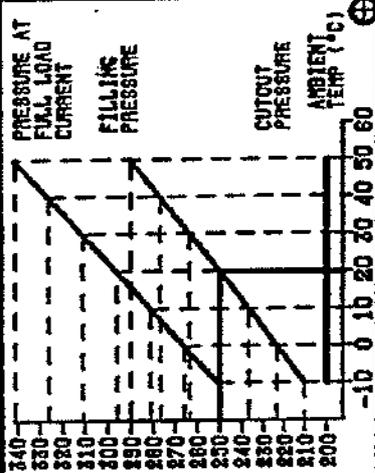

107 E

YSF6 250KPa 2.5BAR 40KA "PUFFER"



## 2. DELIVERY & ERECTION

### 2.1 Typical Minimum Delivery Weights for 630A & 1250A Units

2.11 Note that these weights may be significantly exceeded where numerous auxiliaries are fitted,

2.12 Moving portion complete: 280Kg

2.13 Single busbar fixed portion: 280Kg

Extra for duplicate busbars: 60Kg

Extra for voltage transformer: 100Kg

Extra for bus section: 70Kg

### 2.2 Loading, Delivery and Unloading

2.21 YSF6 units are designed for indoor service and may be carried on open trucks ONLY if adequately secured and tarpaulined against the weather.

2.22 Because of the size and weights of the units, some form of lifting and handling equipment is essential for unloading. The safe working load (SWL) of any crane, forklift, rope or sling should be at least twice the weight of any equipment to be lifted, at the maximum angle or radius required by the site layout.

2.23 It is recommended that fixed and moving portions are NOT crane lifted together, but that the moving portions be withdrawn from the fixed portions (see sub-section 4.2) before the latter are removed from their shipping pallets. A 9m (30ft) circumference, endless sling of manilla rope or suitable synthetic material (NOT steel wire) should be used for crane-lifting. One set of lifting lugs will be supplied with each switchboard and they should be fitted to each fixed portion and each moving portion in turn, as shown in Fig 2.2A. A 510mm (20 in) or slightly longer wood spacer block should be available on site. The sling must then be looped as shown to lift the individual fixed or moving portion.

2.24 DO NOT attempt to operate the switchgear until it has been erected, prepared and commissioned as described elsewhere in this manual.

### 2.3 Storage of Switchgear

2.31 YSF6 indoor switchgear must not be left out of doors, even in fine weather, for more than a few minutes unless it is adequately protected by tarpaulins. Even if it is so protected, it must be taken indoors as soon as possible, preferably within 24 hours of delivery.

2.32 If it is to be stored for any length of time before installation it should be kept in a warm, dry room and suitably protected against dust.

### 2.4 Preparation of Switchroom Floor

2.41 We recommend that that foundation channels (93), with spring nuts (94), be employed to ensure a level foundation for YSF6 switchboards. Suitable channels can be supplied by ourselves at an additional cost per switchboard panel. It is possible to dispense with the channels, erect the switchgear directly on to a concrete floor and secure it with rag-bolts or proprietary fixings. However, it is extremely difficult to obtain a sufficiently flat floor finish of  $\pm 1\text{mm}$  in 960mm (1/8 in in 10ft) for an area at least 2440mm (8ft) forward from the trench, and we advise against this method.

2.42 Foundation details vary from switchboard to switchboard. Reference should always be made to the foundation plan supplied for the individual installation. A cable trench or conduits, of size and layout to suit the cables to be used, will usually be required at the rear of the switchboard. Rear access for cable jointing will also be necessary.

22A

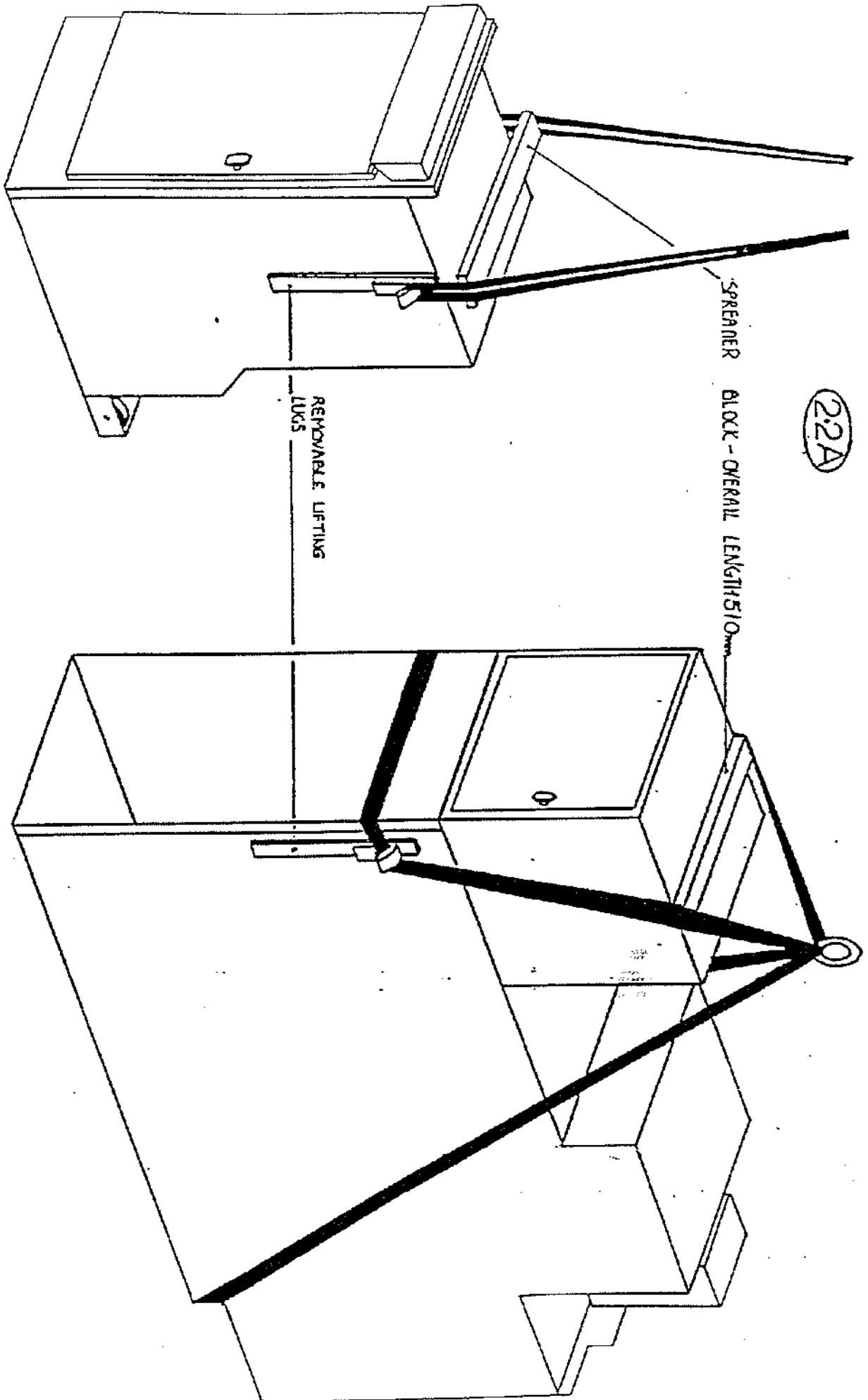

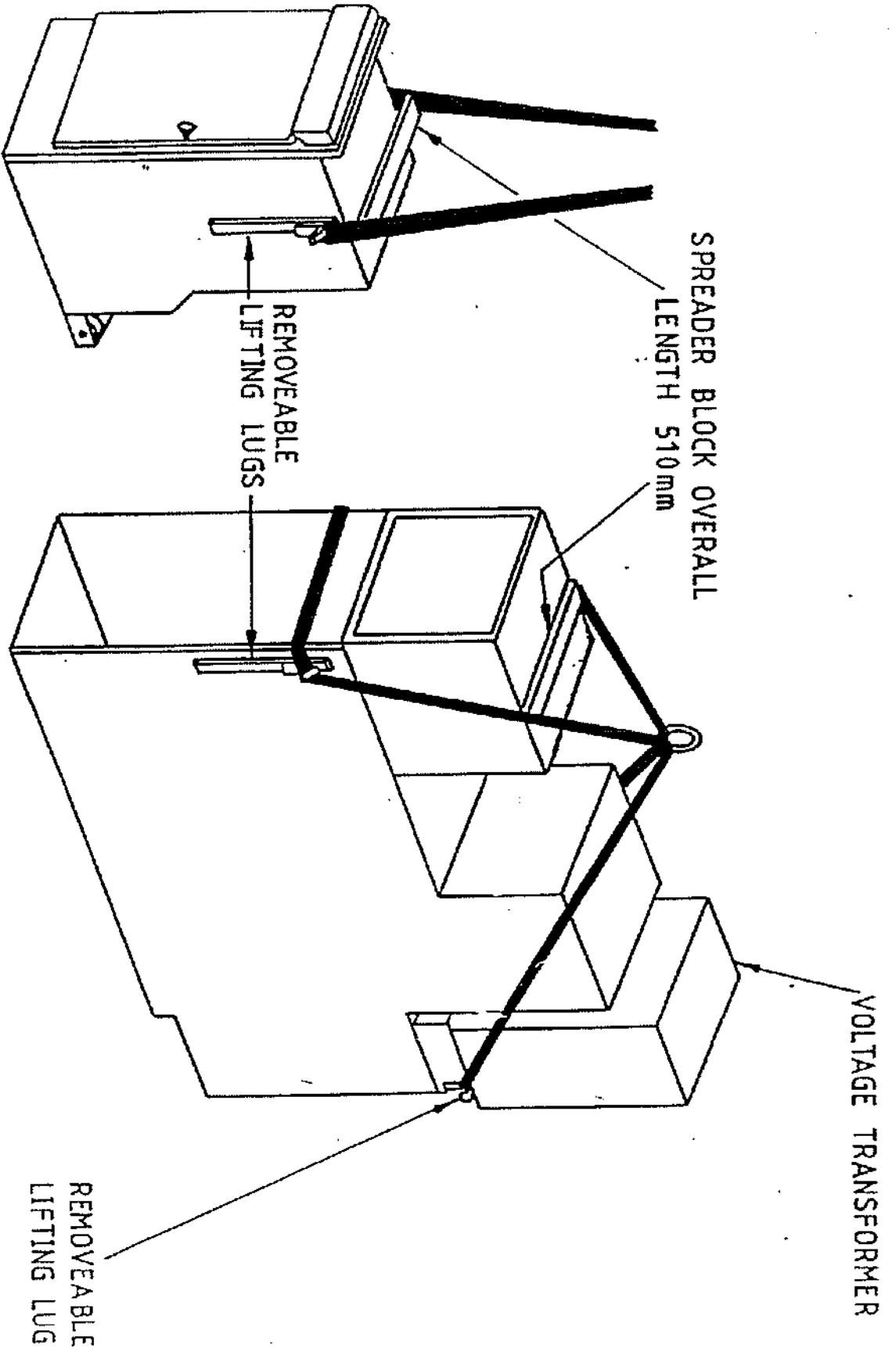

2.2 B LIFTING OF FIXED & MOVING PORTIONS WHEN A VOLTAGE TRANSFORMER IS FITTED.

2AA.a

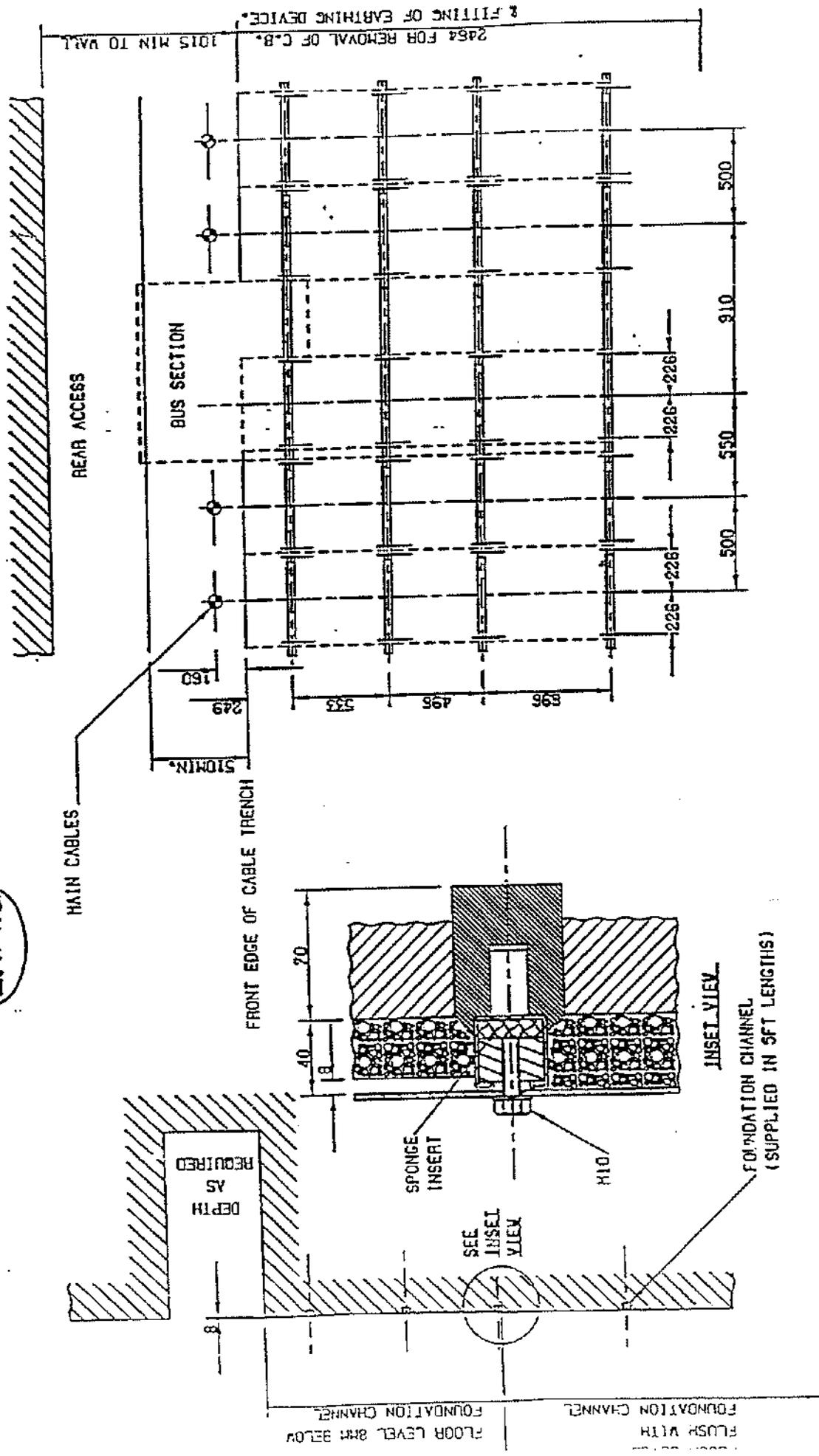

YSF6 FOUNDATION FIXINGS < 15kV

YSF6 FOUNDATION FIXINGS 24 KV

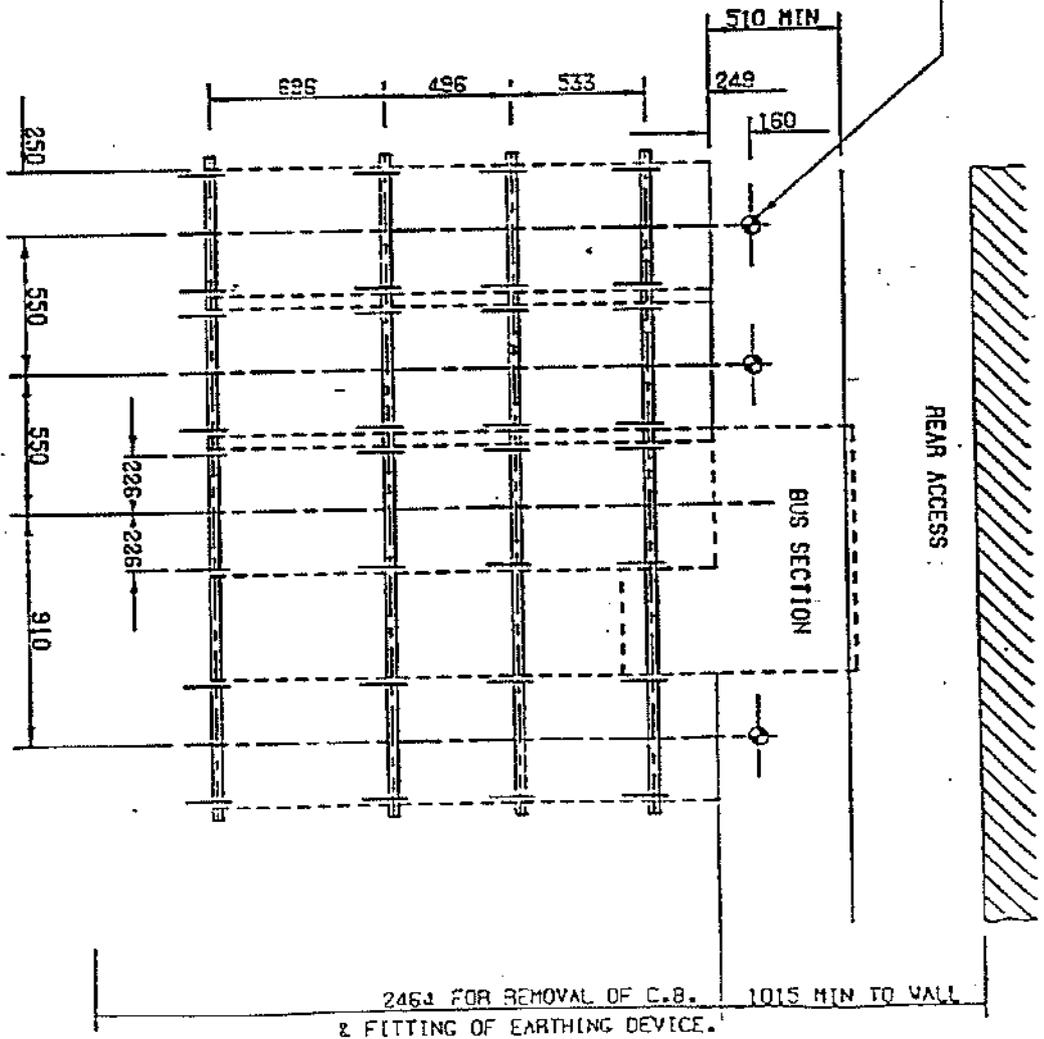
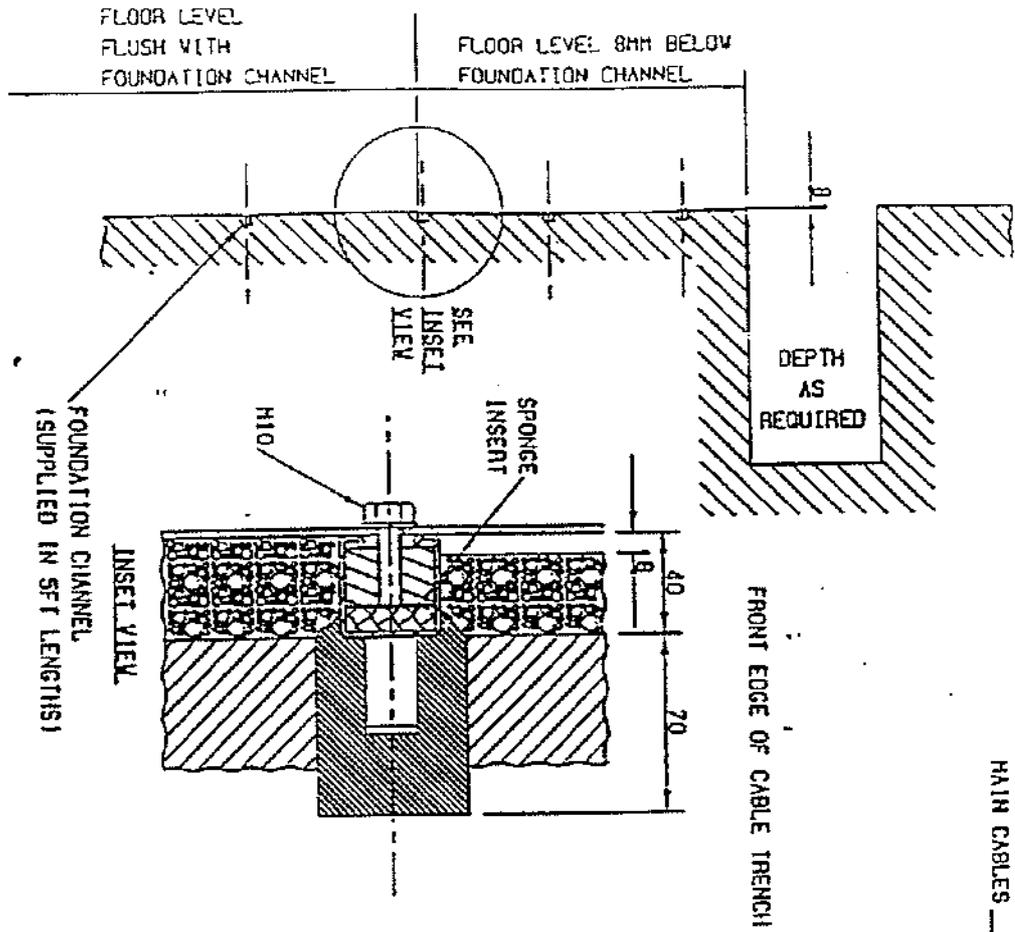

2.4B

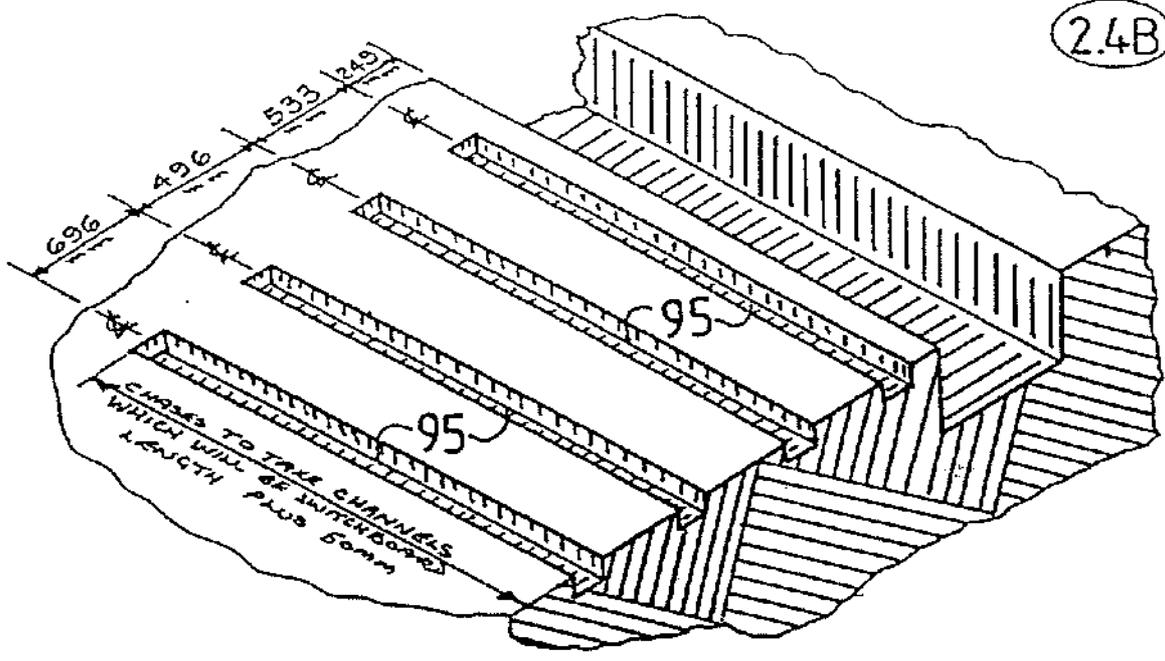

2.4C

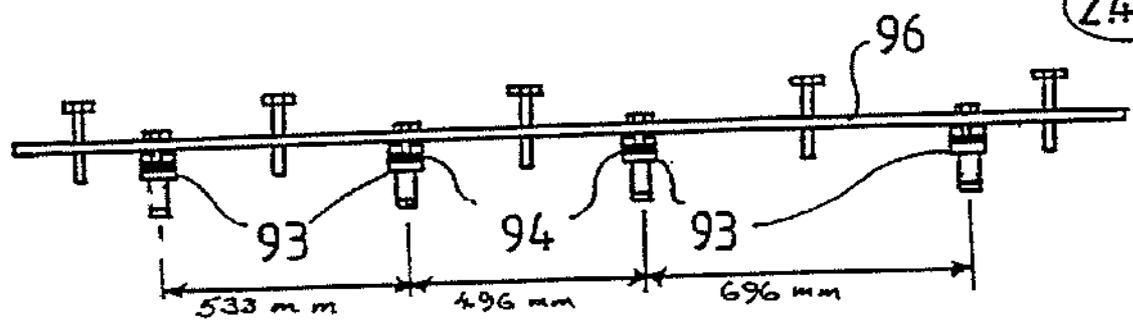

2.4D

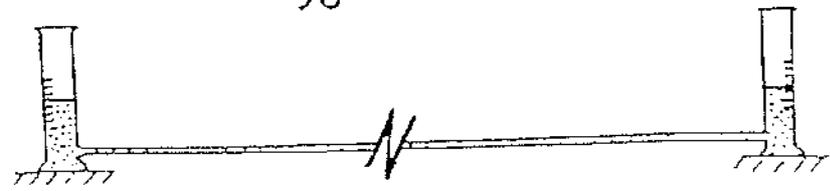
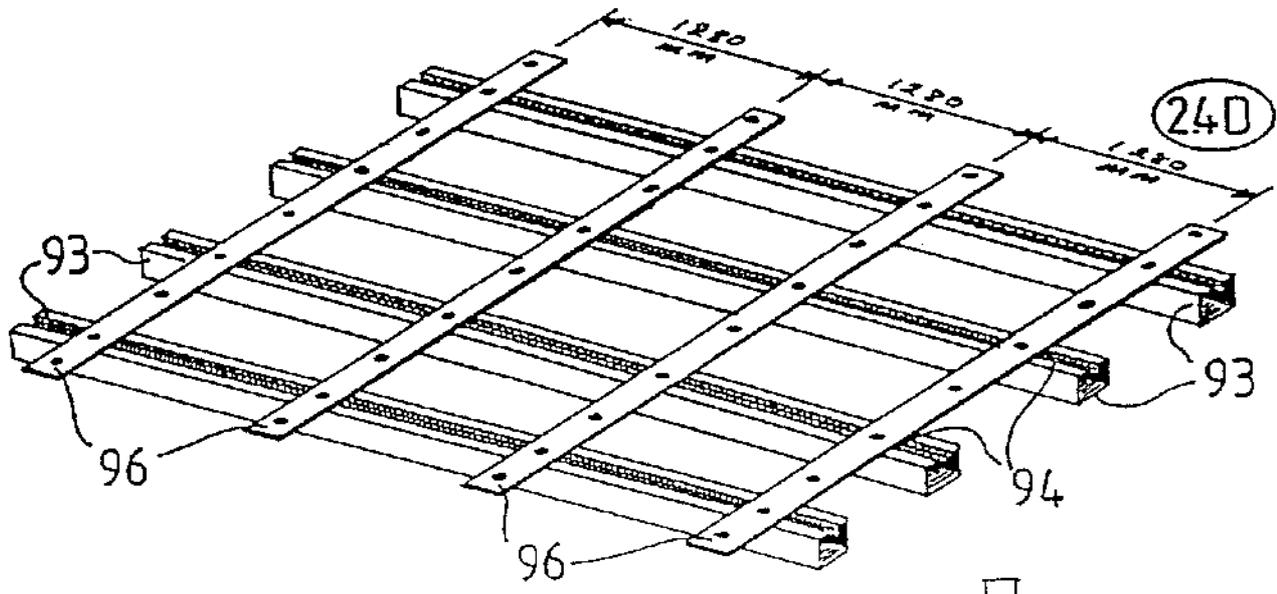

2.4E

- 2.43 Prepare a sub-floor 40mm (1.5/8 in) below finished floor level, with chases (95) a further 70mm (2.1/2 in) deep by 100mm (4 in) wide, as shown in the diagram, to accommodate the channels. Note that four chases (95) are required, with centres of 249mm plus 533mm plus 496mm plus 696mm from the front edge of the trench. The length of the chases must be sufficient to take channels at least 50mm (2 in) longer than the total ultimate length of the switchboard (including any future extensions).
- 2.44 Place the channels (93) in their approximate positions in the chases and burn 50mm (2 in) gaps in the foam plastic filler at 1280mm (50.4 in) fixing centres, using a blow lamp. Using the sponge backed nuts (94) provided, fix tie bar jigs (96) to the foundation runners (93) at 1280mm (50.4 in) centres as shown in the diagram.
- 2.45 Erect a fixed datum, representing the finished channel top surface level of 40mm (1.89 in) above the prepared sub-floor, half way along the switchboard. Take a water level gauge consisting of two graduated jars connected by a flexible pipe of at least 3/4 of total switchboard length and fill with water, taking care to remove all trapped air from the pipe by letting the pipe lie flat on the floor. Place both jars on the datum and note their common reading. On short switchboards a spirit level and long straight edge may be used. Alternatively, a laser levelling system can be employed.
- 2.46 Check by measuring corresponding diagonals that the channel/tie bar assembly (93/96) is 'square'. Position small pieces of steel plate under the levelling screws, and ensure that the centre of the rear runner is 249mm from the cable trench at both ends. Where two or more lengths of channel are to be butted end to end, they must line up exactly.
- 2.47 Leaving one of the water level jars on the datum, place the other on top of each runner (93) in turn along the length of the switchboard, each time adjusting the local jacking screws until the previously noted common water level is attained. This will result in the runners being level over the full length of the switchboard. A tolerance of  $\pm 0.5\text{mm}$  is acceptable.
- 2.48 Grout the channels (93) in position, with the grout filling the chases and approximately half way up the channel sides. When the grout is fully set, remove the tie bars (96) and sprung nuts (94) from the runners.
- 2.49 Float the finished floor between the channels (93), the level being 8mm below the tops of the runners in the areas between the second channel and the front of the trench. This is to allow for the protrusion of rivet heads below the housing baseplates, while still giving adequate support when the moving portions are plugged in. Take care not to get concrete into those parts of the channels from which the foam has been removed. When the switchboard floor area has set, float the rest of the floor in front of the second channel up to the level of the top of the channel (see diagram).
- 2.5 Erection of Fixed Portion**
- 2.51 Using the contract drawings as a guide, burn 50mm (2 in) gaps in the channel foam plastic filler at the fixed portion fixing points with a blowlamp. Position the spring nuts (94) at these points.
- 2.52 Alternatively, drill holes in the plain concrete floor at the appropriate centres and grout in proprietary fixings tapped M10 (3/8 in) in accordance with the foundation drawing.
- 2.53 At each panel, unfasten, remove and store the busbar chamber rear and/or top and/or front access plates (97, 98). Place the first unit in position and fasten down to the foundation fixings. Rather than fitting the busbars once all the fixed portions have been fastened down, you may find it easier to fit the busbars to one panel at a time as the board is erected, when you will have side, as well as top or rear access to each unit's busbar chamber. See sub-section 2.6 of this manual for details of busbar fitting.

VIEW ON  
ARROW "A"

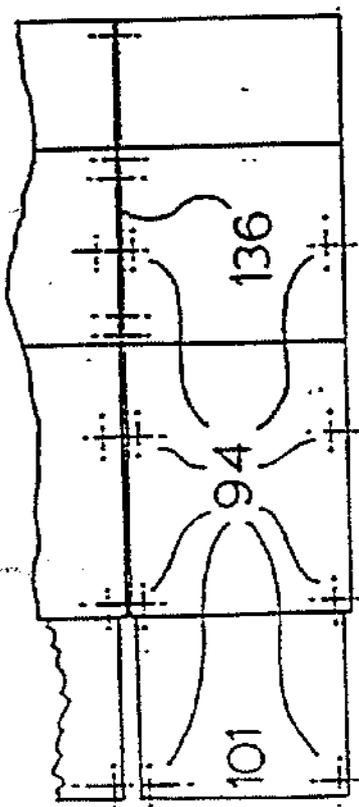

25A

500mm crs ( $\leq 15$ kV)

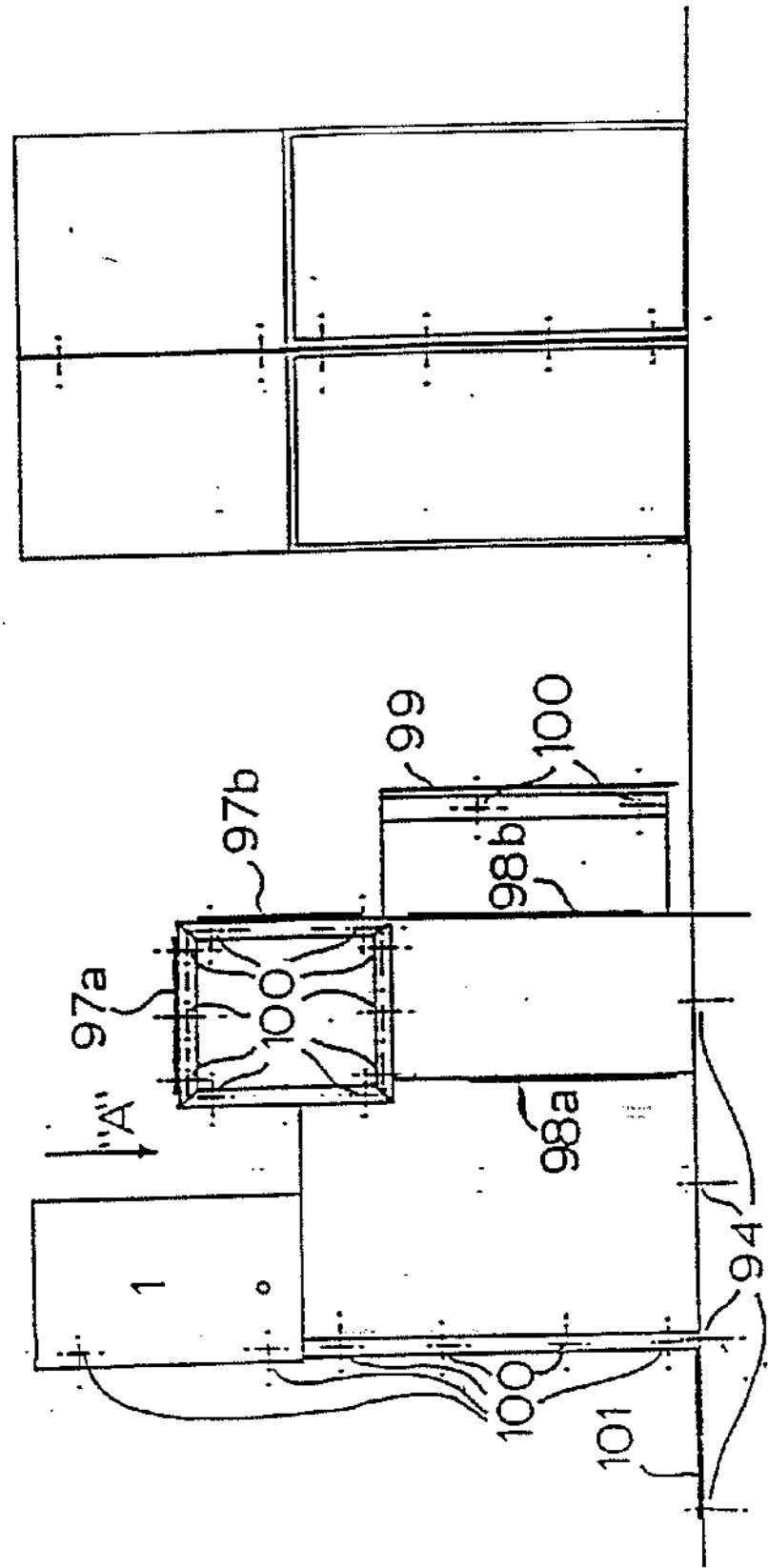



VIEW ON ARROW

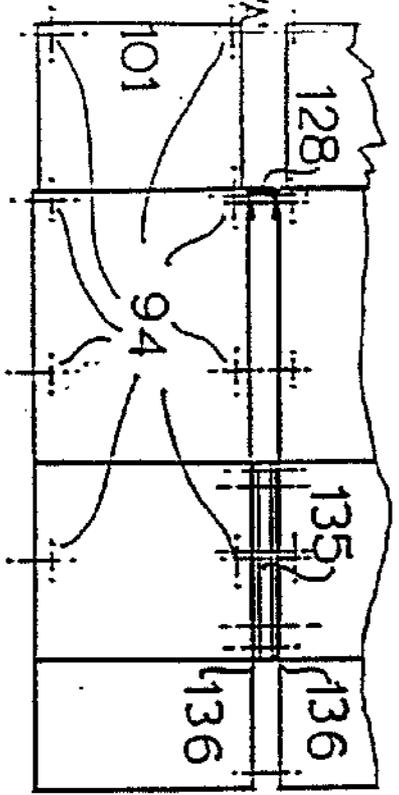

25B

550mm crs (≤ 24kV)

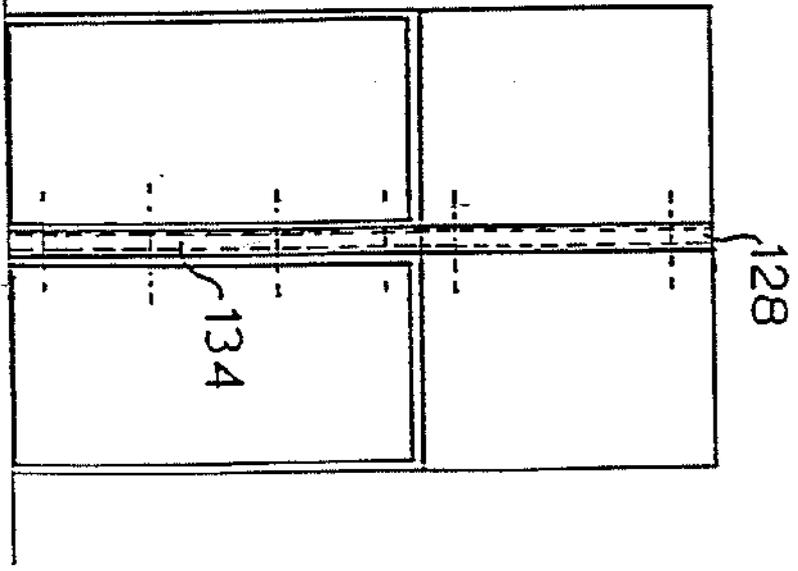
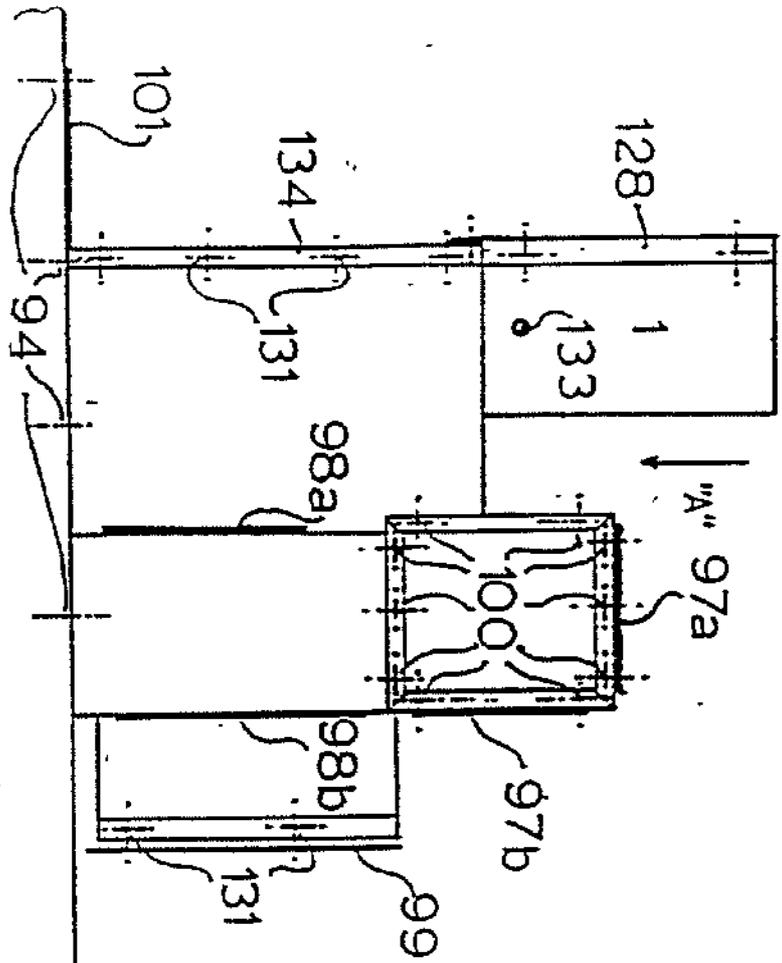

(2.5B) supplement

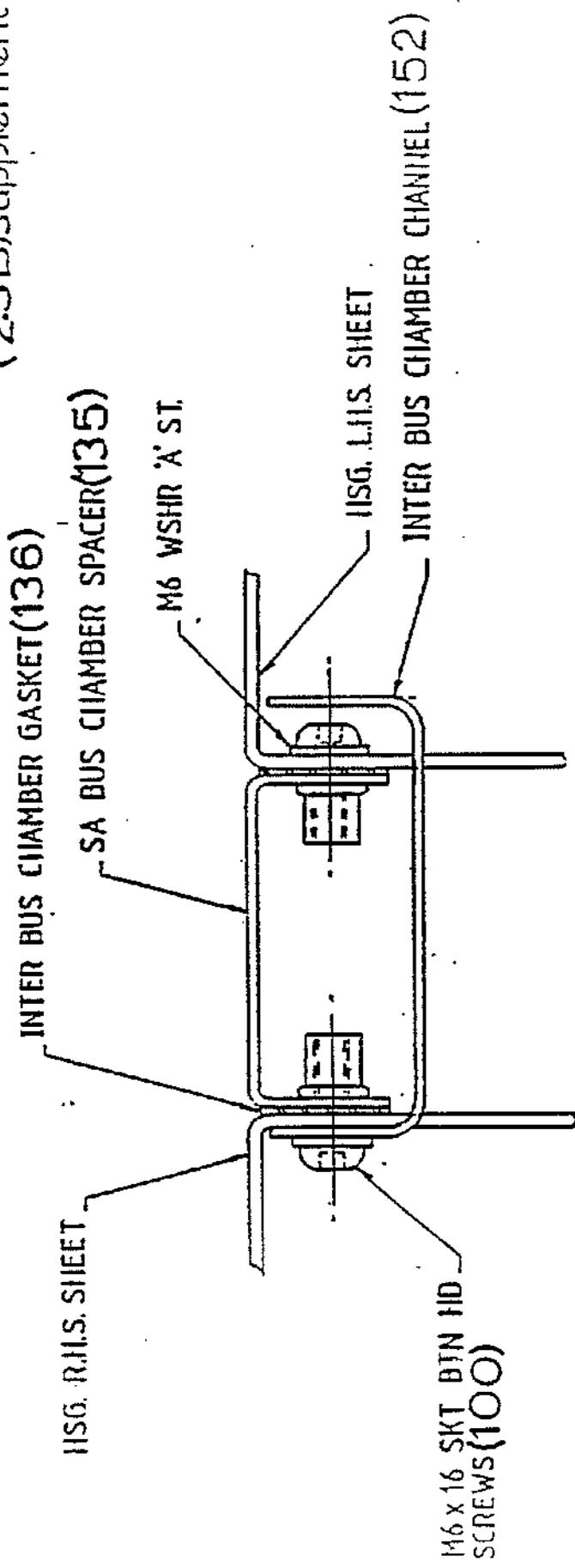

REMOVE 10-OFF M6 SCREWS. PLACE CHANNELS IN POSITION AND SECURE BY REPLACING M6 SCREWS.

### FITTING OF 24KV BUS CHAMBER CHANNELS

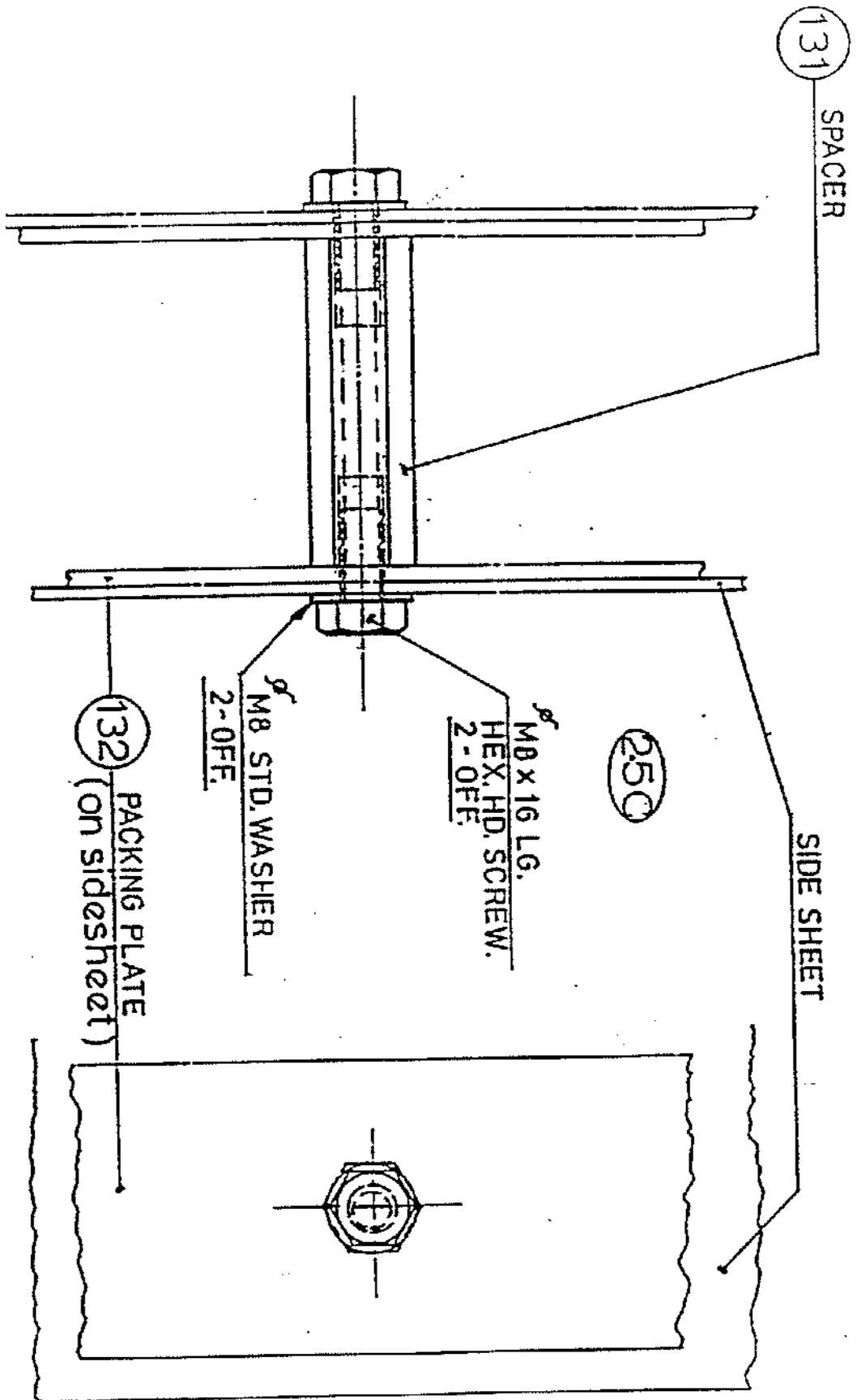

FITTING OF HOUSING SPACERS [550mm CRS]

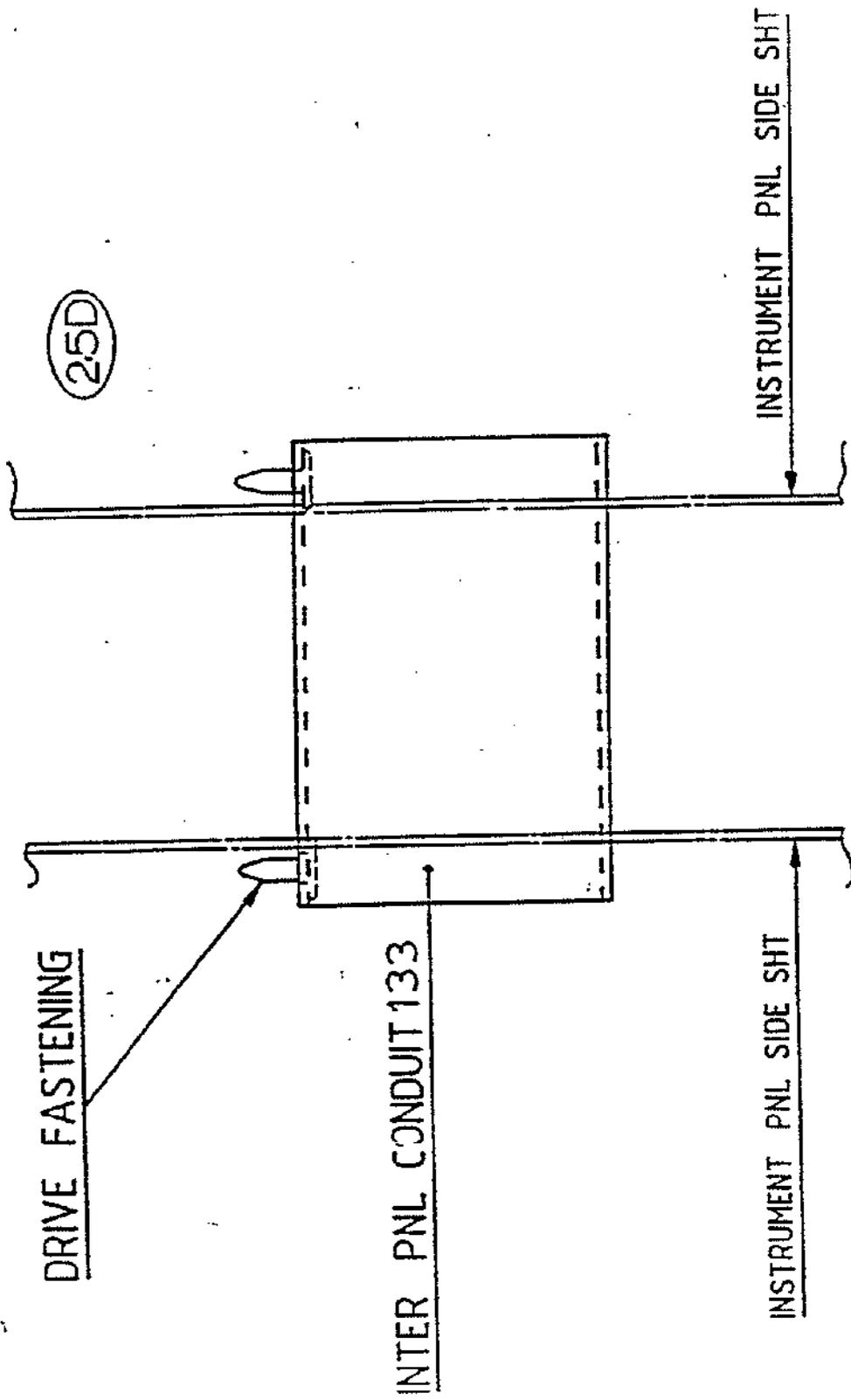

S. A. INTER PANEL CONDUIT

- 2.54 In the case of 500mm centre units, (i.e those up to 15kV ratings), place and fasten the second unit in position and fit the screws, nuts and washers (100) provided so that the front and rear edges of the side wall of the adjacent unit are fastened together. The busbar chambers must also be fastened together with gaskets between their edges, using the ten pairs of fastening holes provided. Fasten down the fixed portion. Connect up the secondary wiring between adjacent relay panels. Repeat for each panel.
- 2.55 In the case of 550mm centre units, (i.e those above 15kV rating), fasten the two part busbar chamber spacer (135) to one side of the first fixed portion, with a gasket (136) between the spacer and the side of the fixed portion, using the ten pairs of fixing holes provided. At the front and rear edges of the unit, fit housing spacers (131) at the locations indicated. Fasten the U section lower fascia plate (134) to the front edge of the fixed portion, using the two pairs of fastening holes provided. Fasten the U section instrument panel fascia plate (128) to the side of the instrument panel (1) using the pair of holes provided. Fasten the bottom end of the instrument panel fascia plate to the top end of the lower fascia plate using the pair of holes provided.
- 2.56 Place the next 550mm unit in position alongside the first. Fasten the new fixed portion to the previously fitted busbar chamber spacer (135), with a gasket (136) between. Fasten the front and rear edges of the housing to the housing spacers (131). Also, fasten the front edges of the new housing and instrument panel to the lower (134) and upper (128) U shaped fascia plates. Fit a conduit (133) between the two instrument panels using the push in fastening provided. Fasten down the fixed portion. Connect up the secondary wiring between adjacent relay panels. Repeat for each panel.
- 2.57 Check with a spirit level and tightened cord that the units are level and in line as you erect each in turn.
- 2.58 Secure each apron (101) to the front of its housing baseplates using the two foremost housing foundation screws. Fasten down the apron fronts to the front channel.
- 2.59 Fit pieces of clip on plastic cover to any exposed lengths of channel, e.g. where provision has been made for future extensions or adjacent to bus section fixed portions.

## 2.6 Fitting the Busbars

- 2.61 The busbars (19) can be fitted to one panel at a time as the board is erected, or, less easily, they can be fitted when the whole switchboard is in position. Unit length, insulated busbars are employed in the following sizes:
- |            |                                  |
|------------|----------------------------------|
| 1250A      | 76mm x 10mm (3 in x 3/8 in)      |
| 2000/2300A | 114mm x 12mm (4.1/2 in x 1/2 in) |
- 2.62 Each end of each busbar section is slipped into one sleeve of a tee off shroud (91) and secured with screws, nuts and washers to a tee off connection (105) incorporated in a busbar support moulding (90). Fishplate packers (106) are used to match up the sections of busbar which protrude beyond the tee off connections. One each end panel an additional packer (107) is used to take the place of the second busbar, and a shroud having only one busbar sleeve is employed. In the case of 630A circuit tee off connection (105) a further offset packer (115) is employed. The M10 screws should be tightened to 47.5Nm (351bsf ft).
- 2.63 With shrouds and busbars in place, the shroud covers (92) can be fitted. In the case of units requiring an impulse level in excess of 95kV, a cold pouring sealant must now be injected into the shrouds. The sealant comes in packs with instructions on application. It is loaded in a special container and applied as follows:
- 2.64 The shroud covers (92) are clamped in place using a special jig (108) secured by a 'Ty-rap'. At each joint, one cover is fitted with the filling nipple pointing upwards, the other with it pointing downwards. Fit the filling nozzle (109) from the sealant container to the lower nipple and pump in sealant until it begins to leak from the upper nipple. Continue to pump until the shroud is completely full (i.e. not readily compressible), holding the upper nipple closed if necessary.
- 2.65 Remove the jig (108) and nozzle (109) and repeat for the other shrouds on the board.
- 2.66 The equipment has two or three earth bars (13) which must be connected up between units and bonded to the substation earth according to local practice. The locations of the earth bars are (a) on the fixed portion top plate behind the instrument panel; (b) adjacent to the cable box gland plate; (c) on transfer earth equipped units, behind the star point contacts (16). Access to the last type is through the access plates (98a, 98b) which would give access to the lower busbar chamber on a duplicate busbar switchboard.
- 2.67 At each end panel, a busbar end cover (137) must be fitted to each busbar chamber. The panel is in two halves and is secured by four clamps (138) on the outside which are held by screws passing from the inside of the cover. A strap (139) and gasket (140) cover the outside of the joint between the two cover halves (137). Studs pass from the strap into the cover and are secured by nuts on the inside.
- 2.68 On completion, clean the busbars (12, 19), shrouds (91, 92) and mouldings (90) as described in detail in sub-section 9.4 of this manual. Remove any dust or debris from the busbar chambers and replace the top and/or rear and/or front access plates (97, 98) and secure them in position.
- 2.69 Connect up the earth bar sections (13) of adjacent units and bond the switchboard earth bar to the substation earth according to local practice. See the diagram for busbar connections at end panels.

2.6A

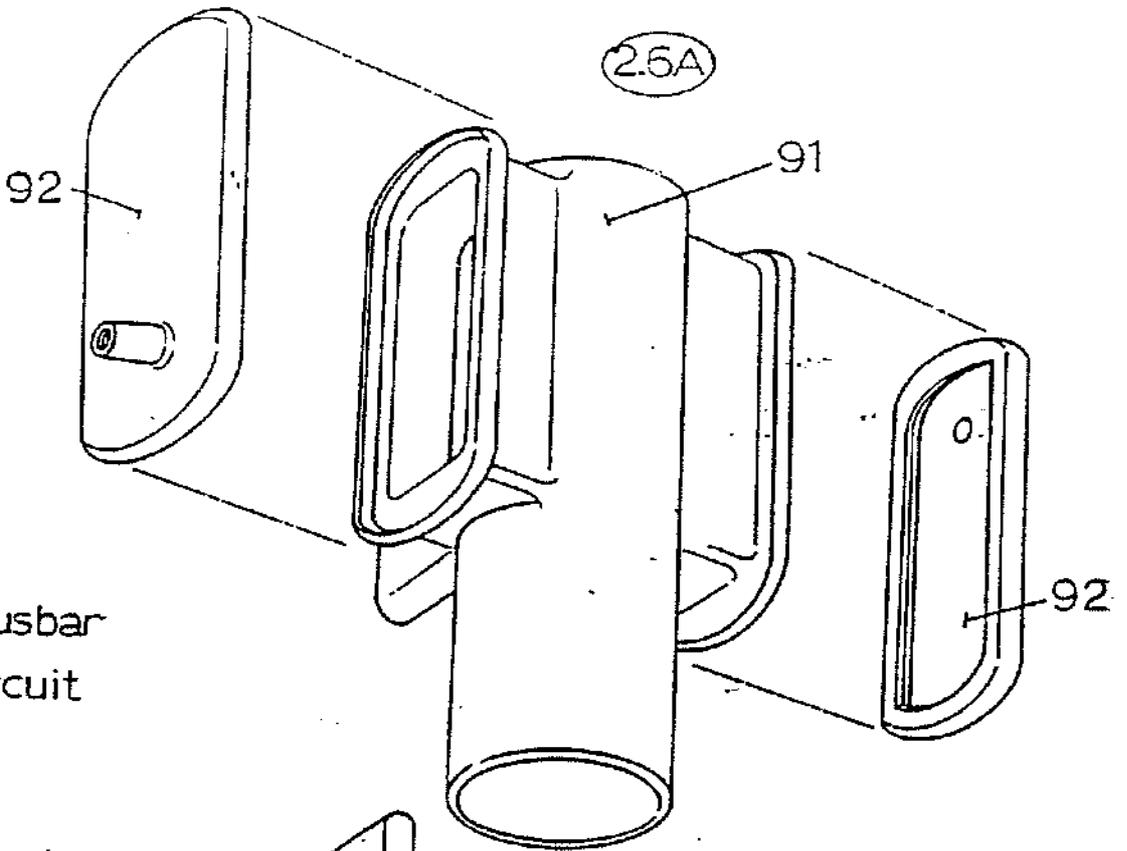

1250A busbar  
630A circuit  
RH end

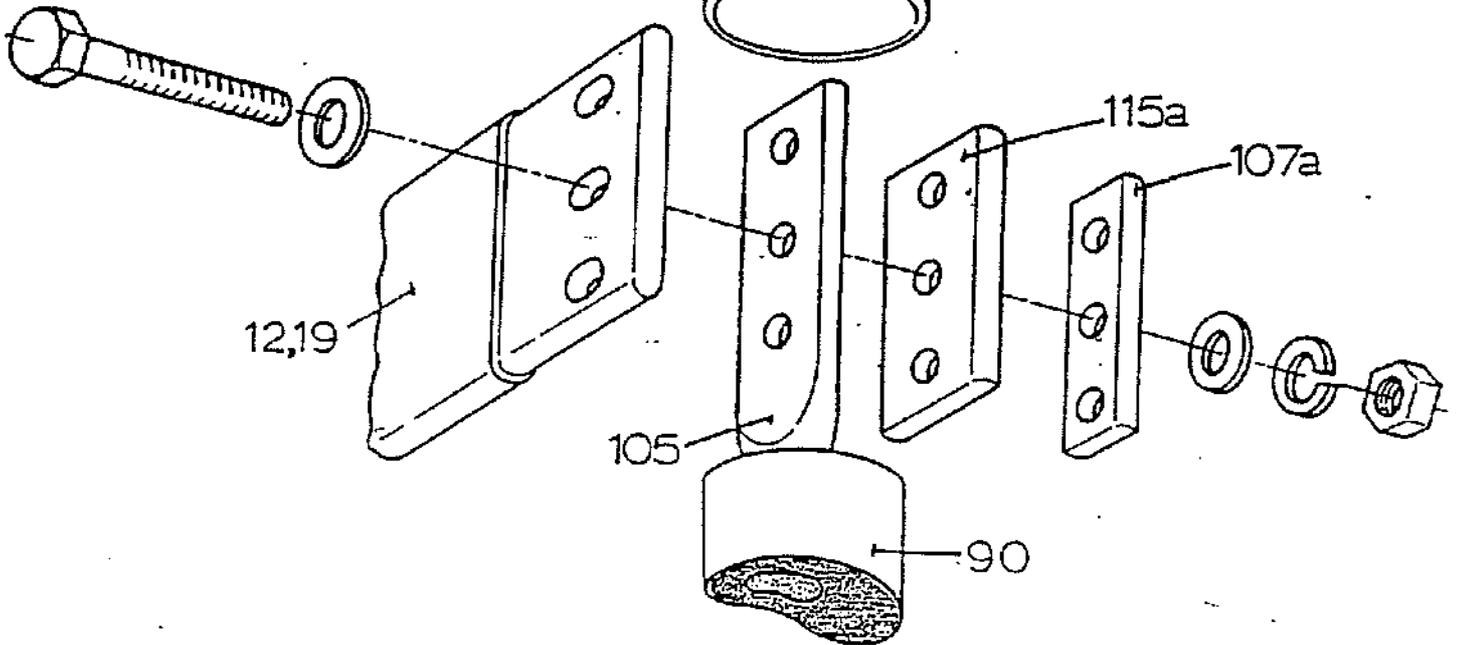

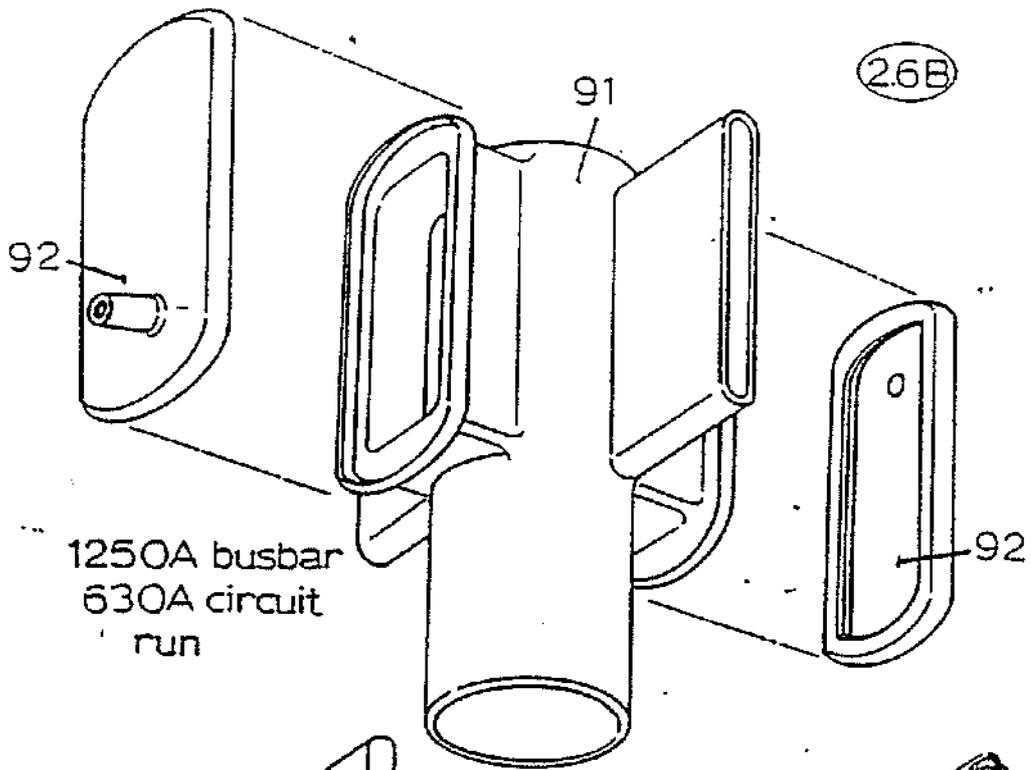

1250A busbar  
630A circuit  
run

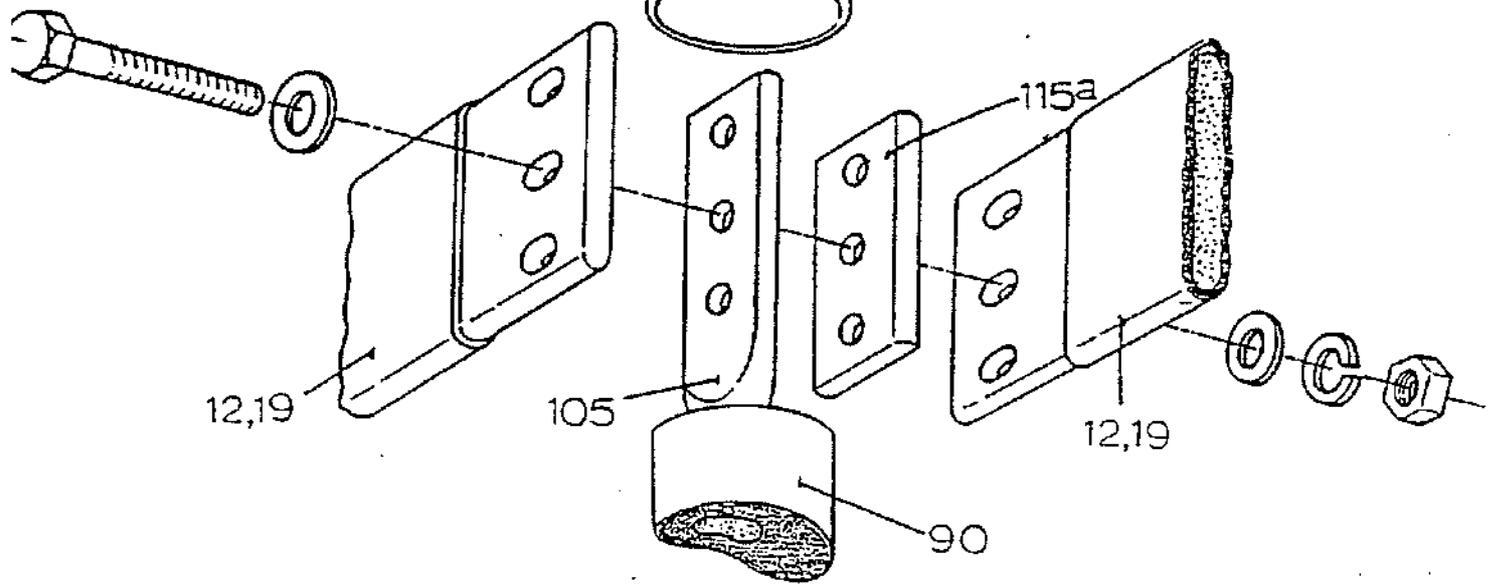



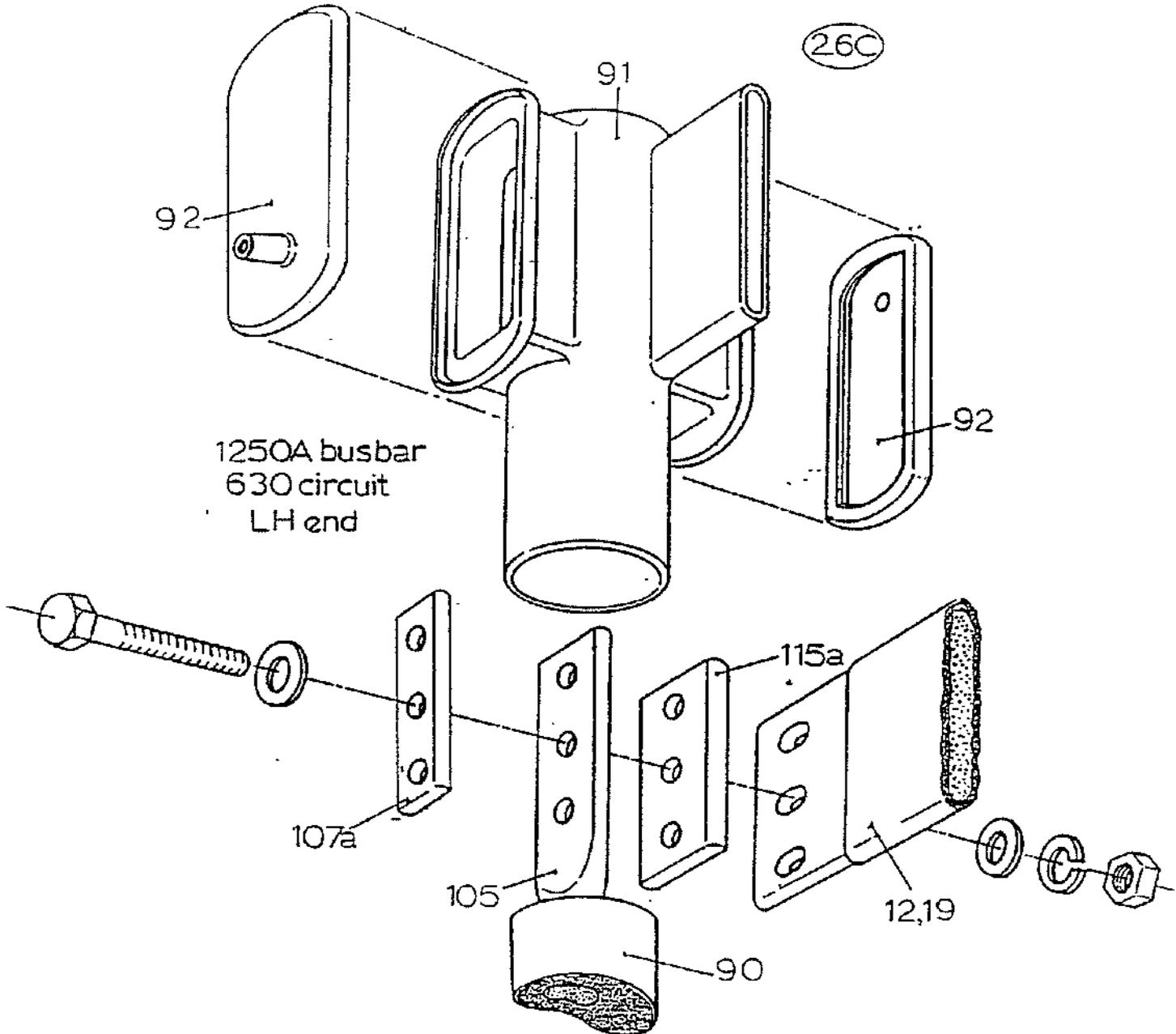

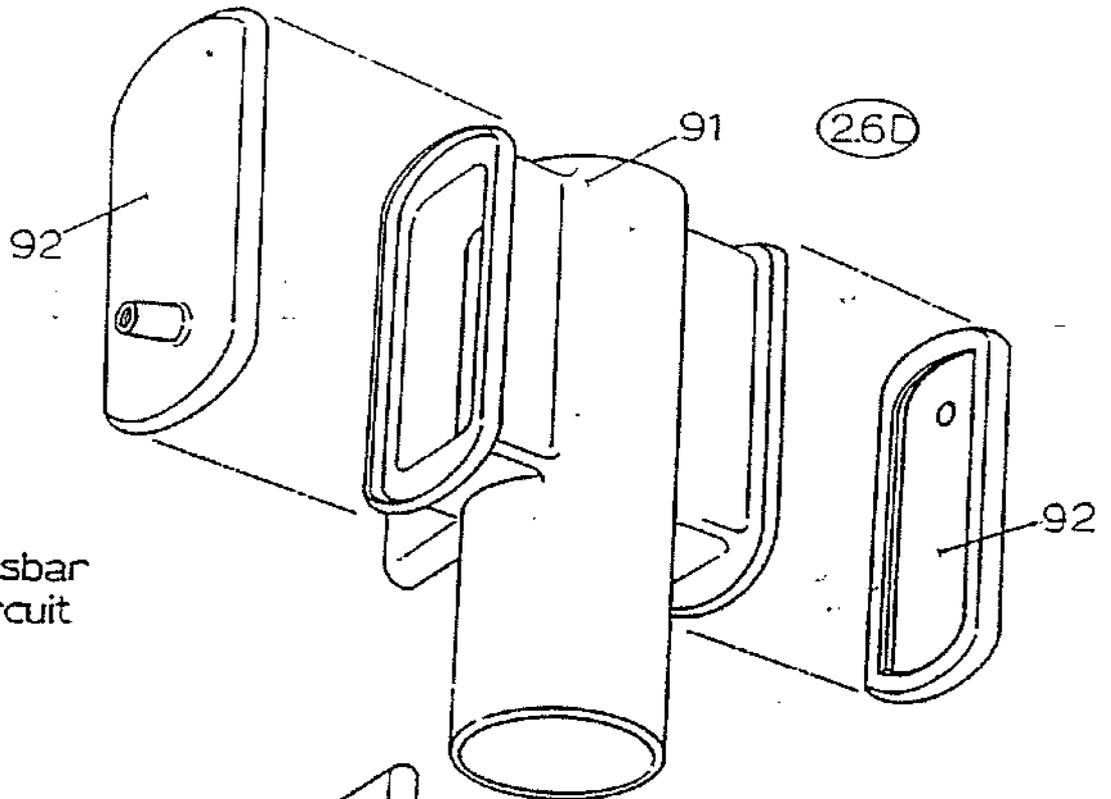

1250A busbar  
1250A circuit  
RH end

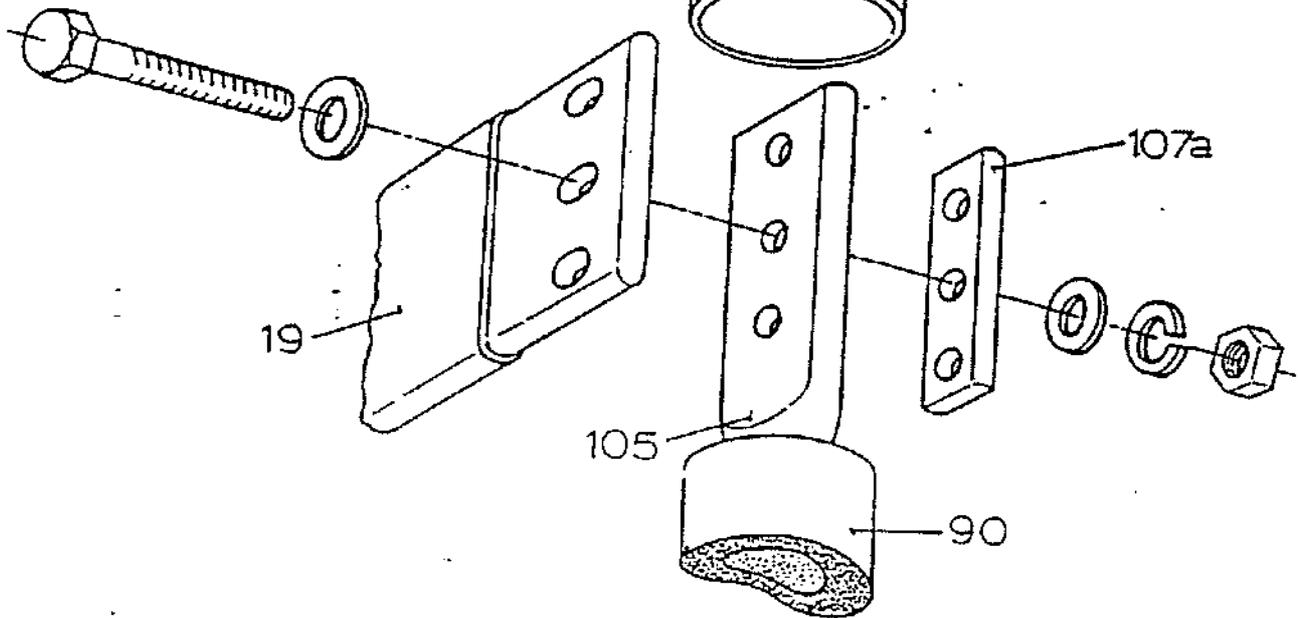

26E

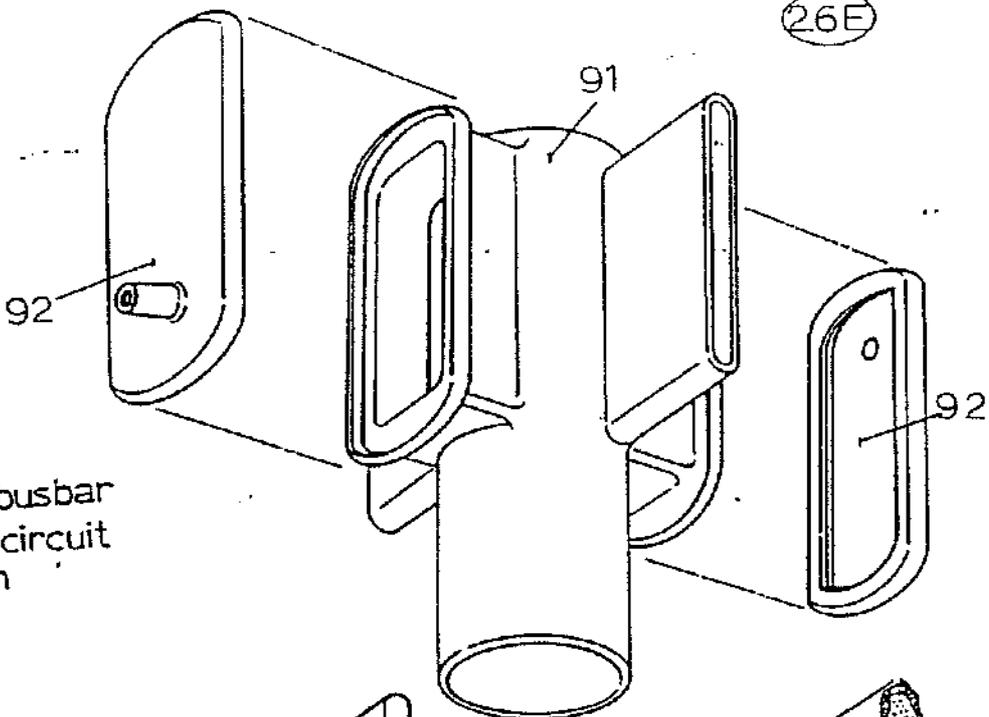

1250A busbar  
1250A circuit  
run

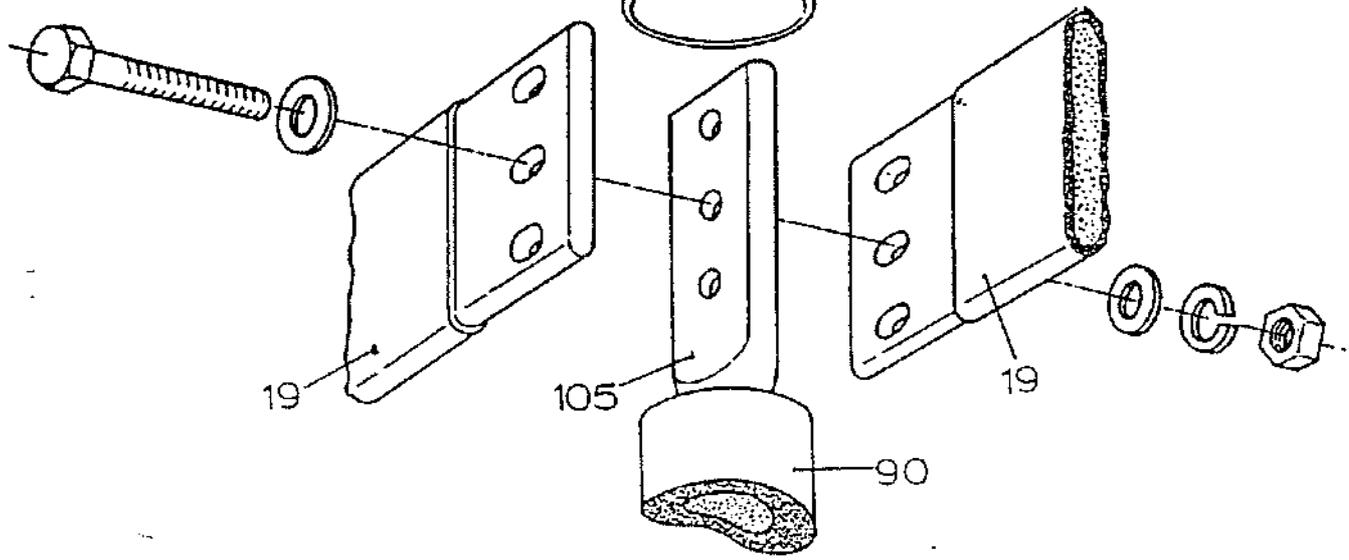

26F

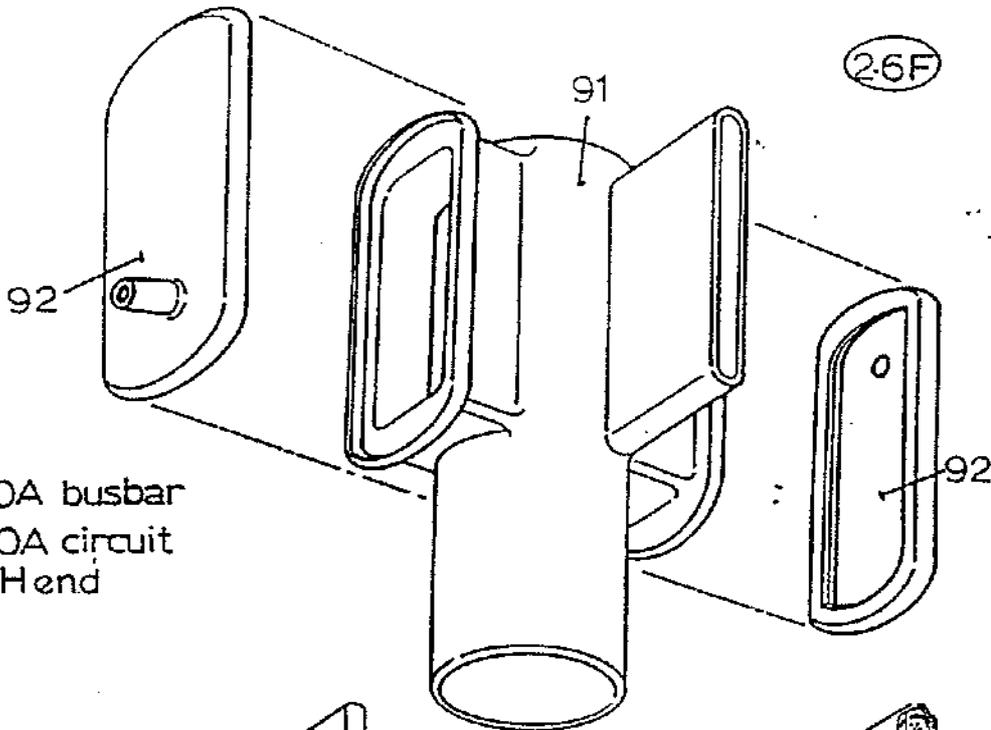

1250A busbar  
1250A circuit  
LH end

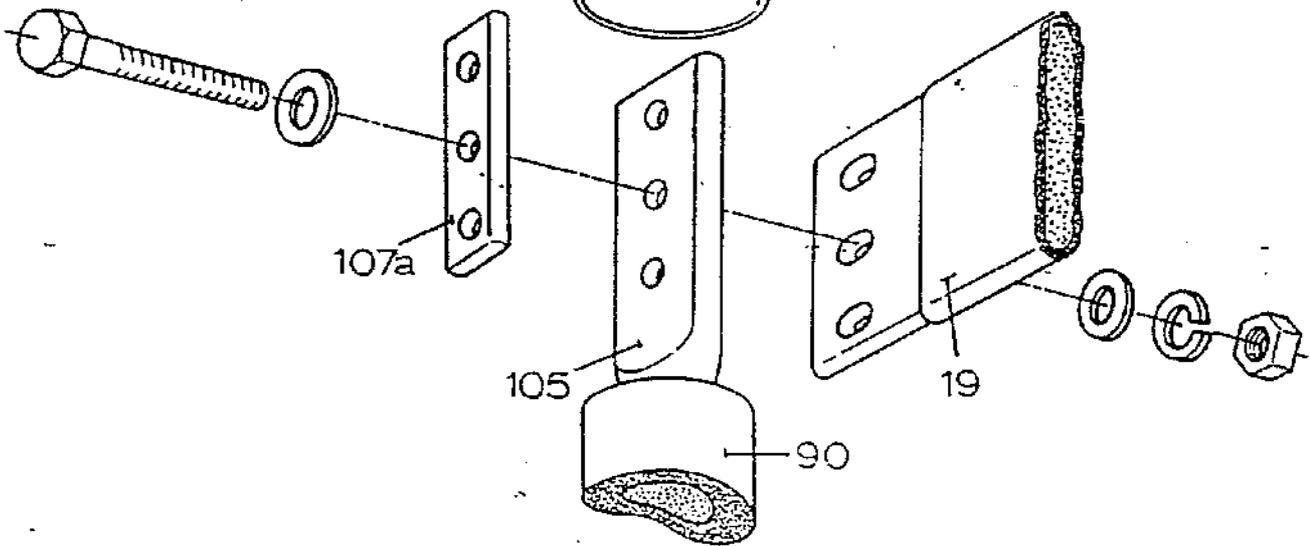

(26G)

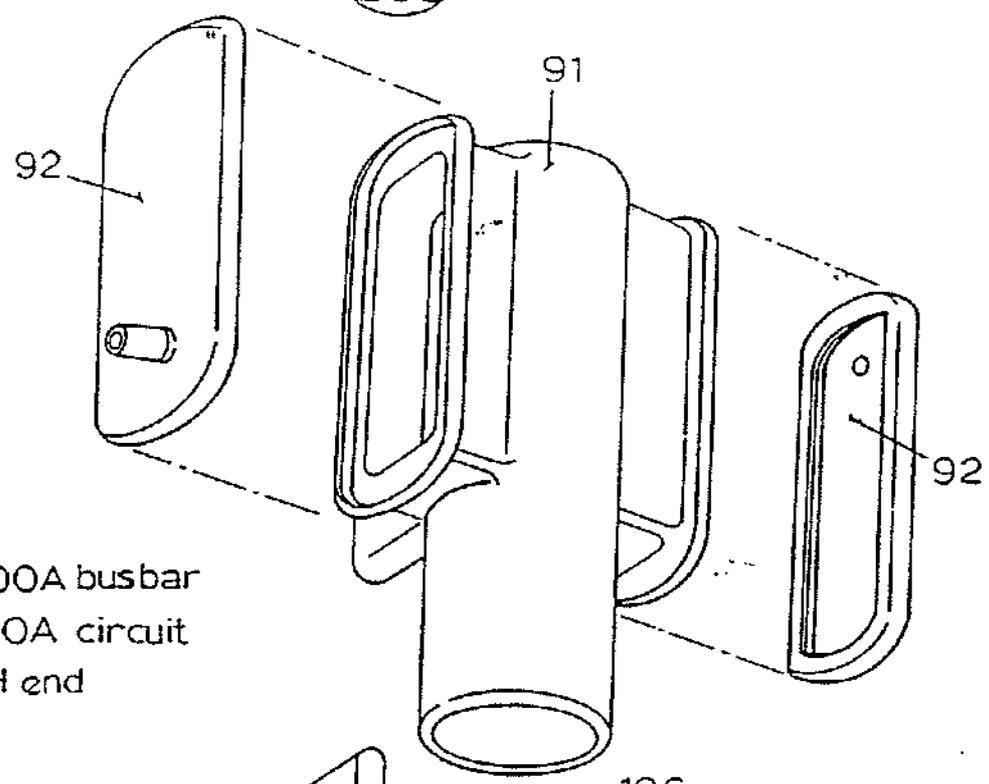

∠2500A busbar  
1250A circuit  
RH end

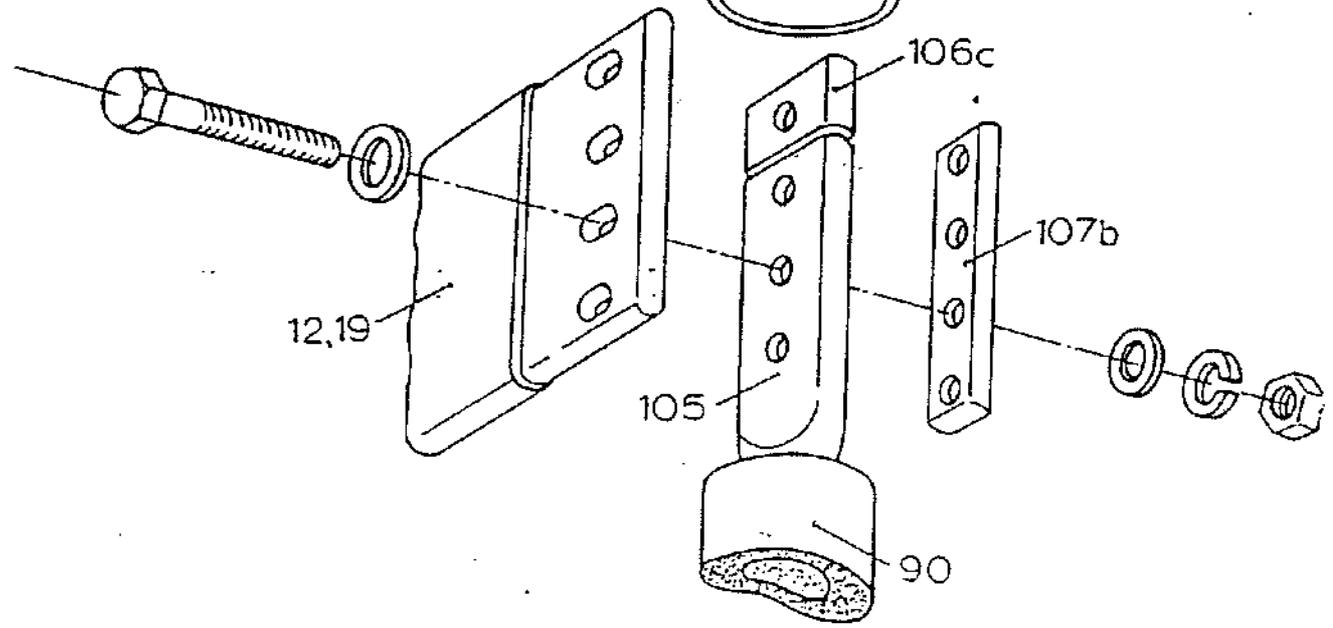

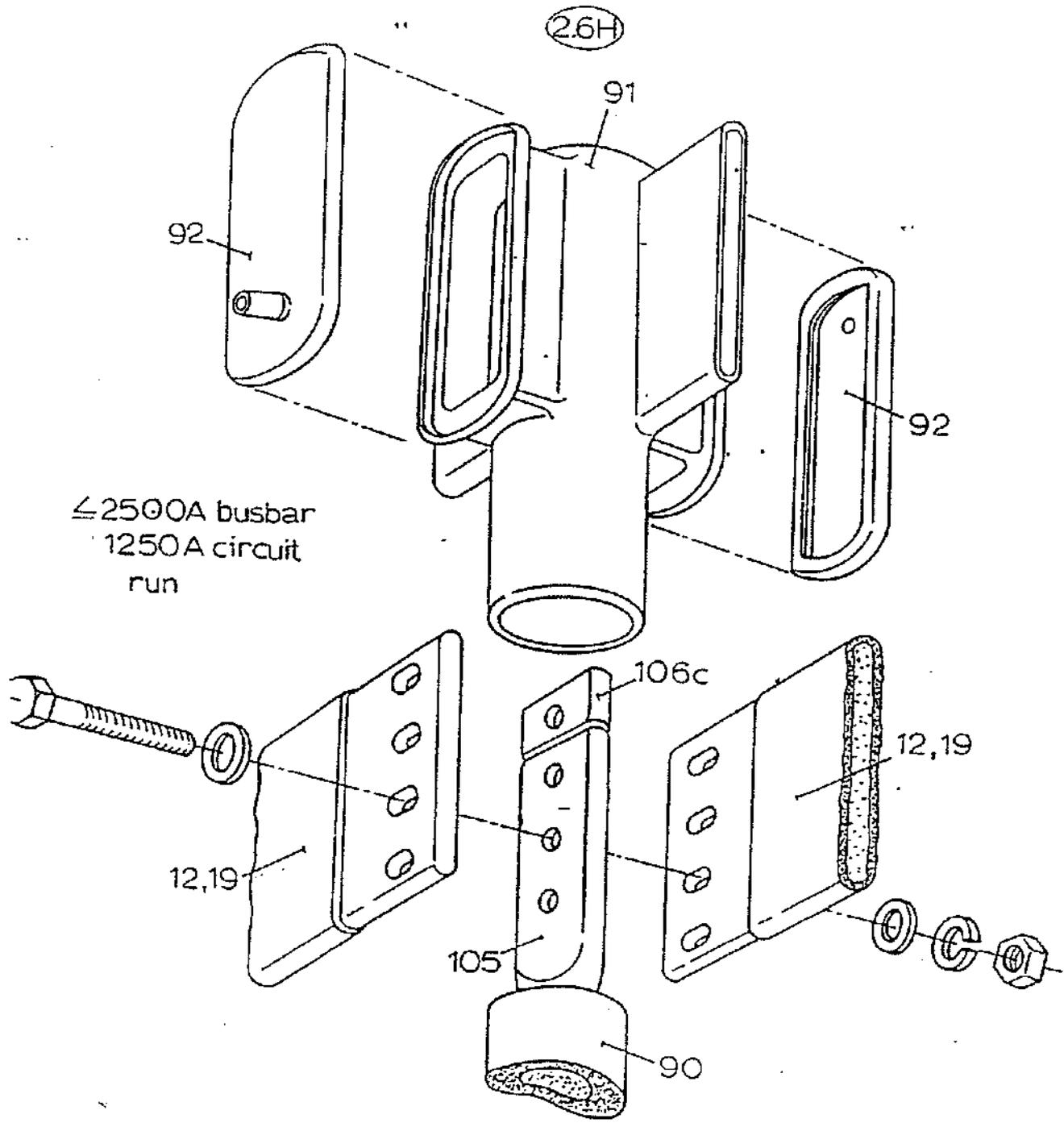

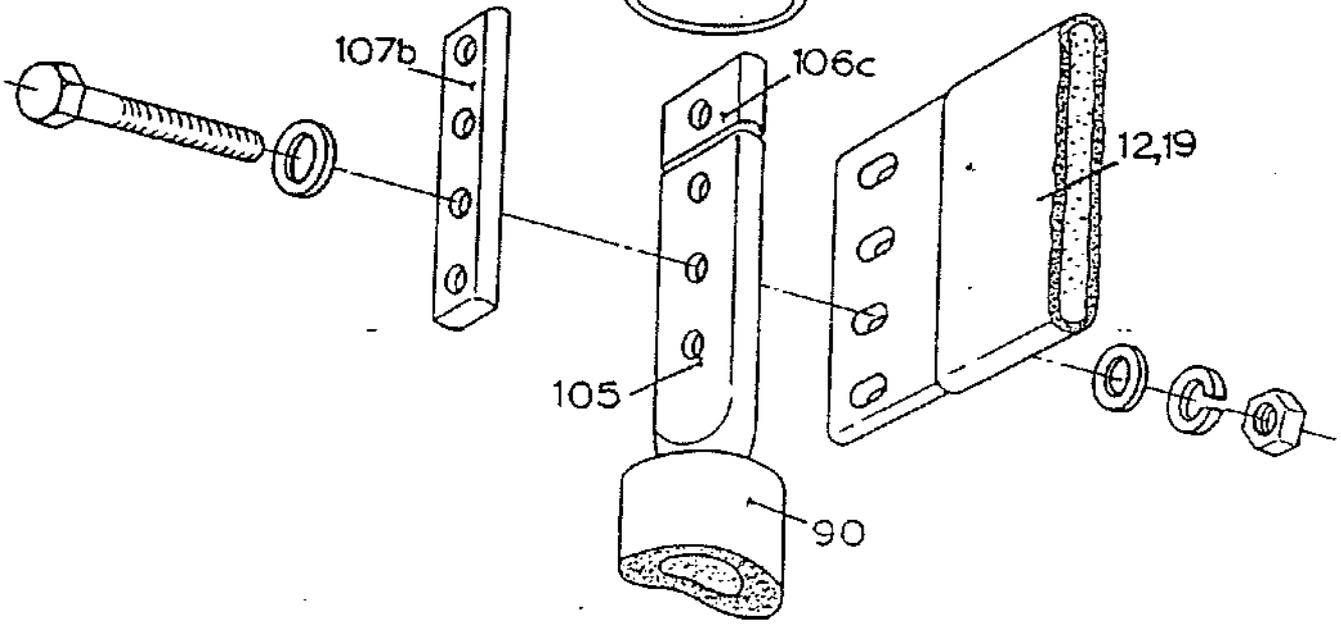
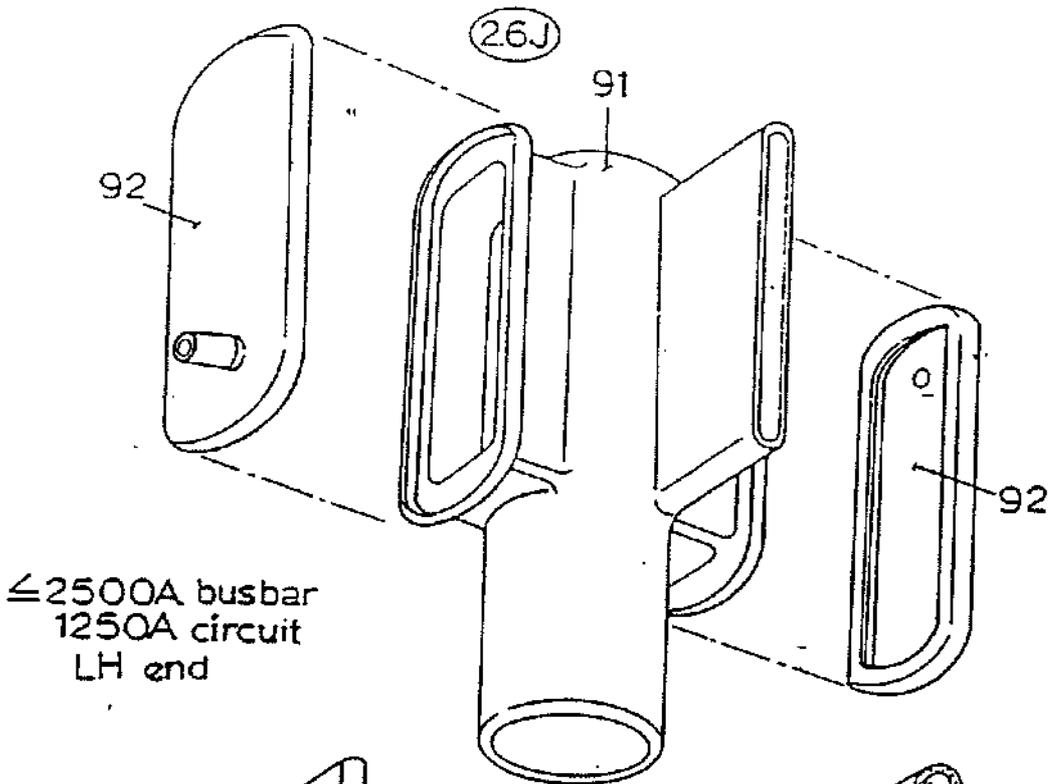

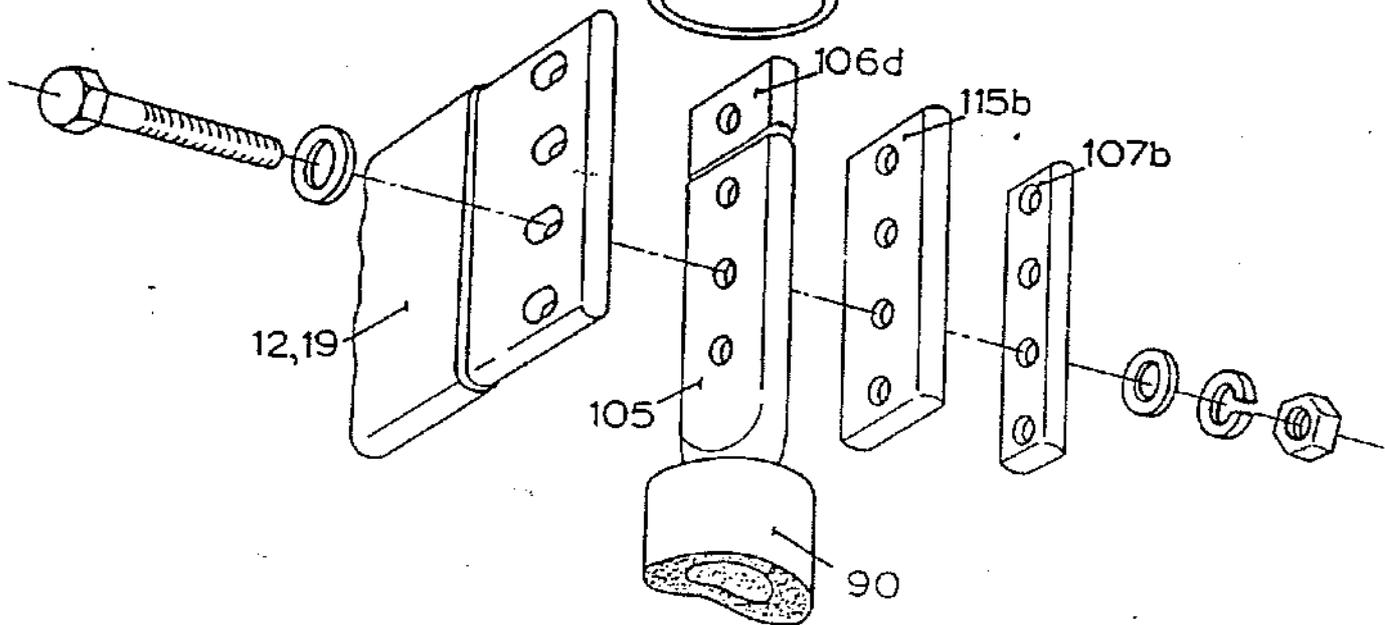
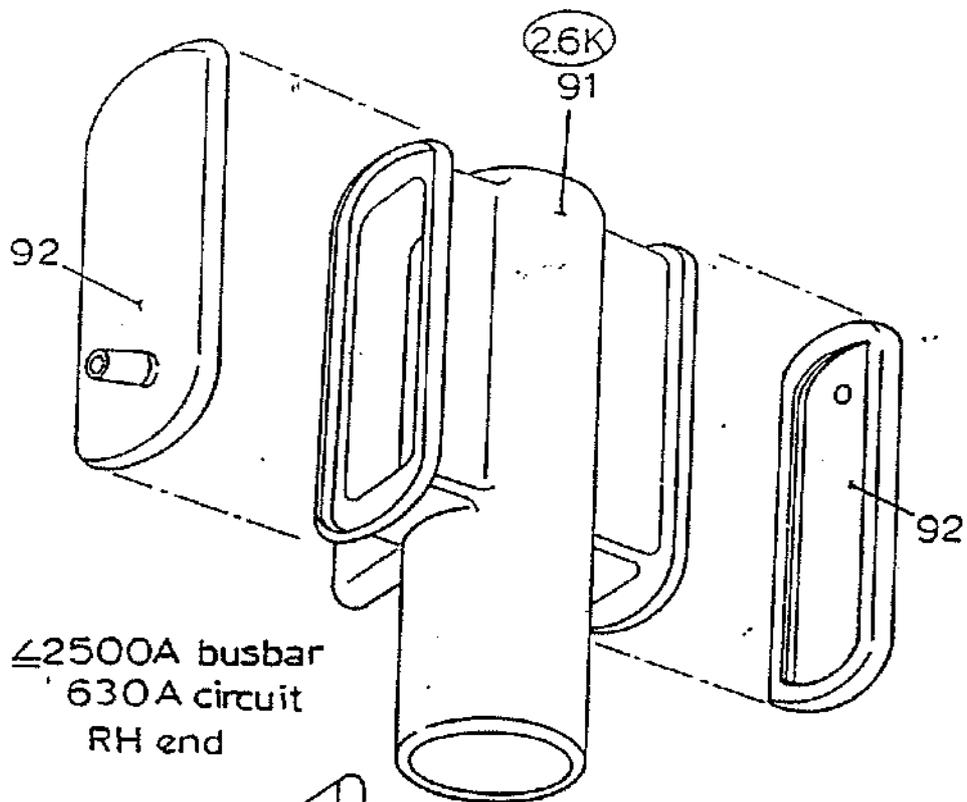



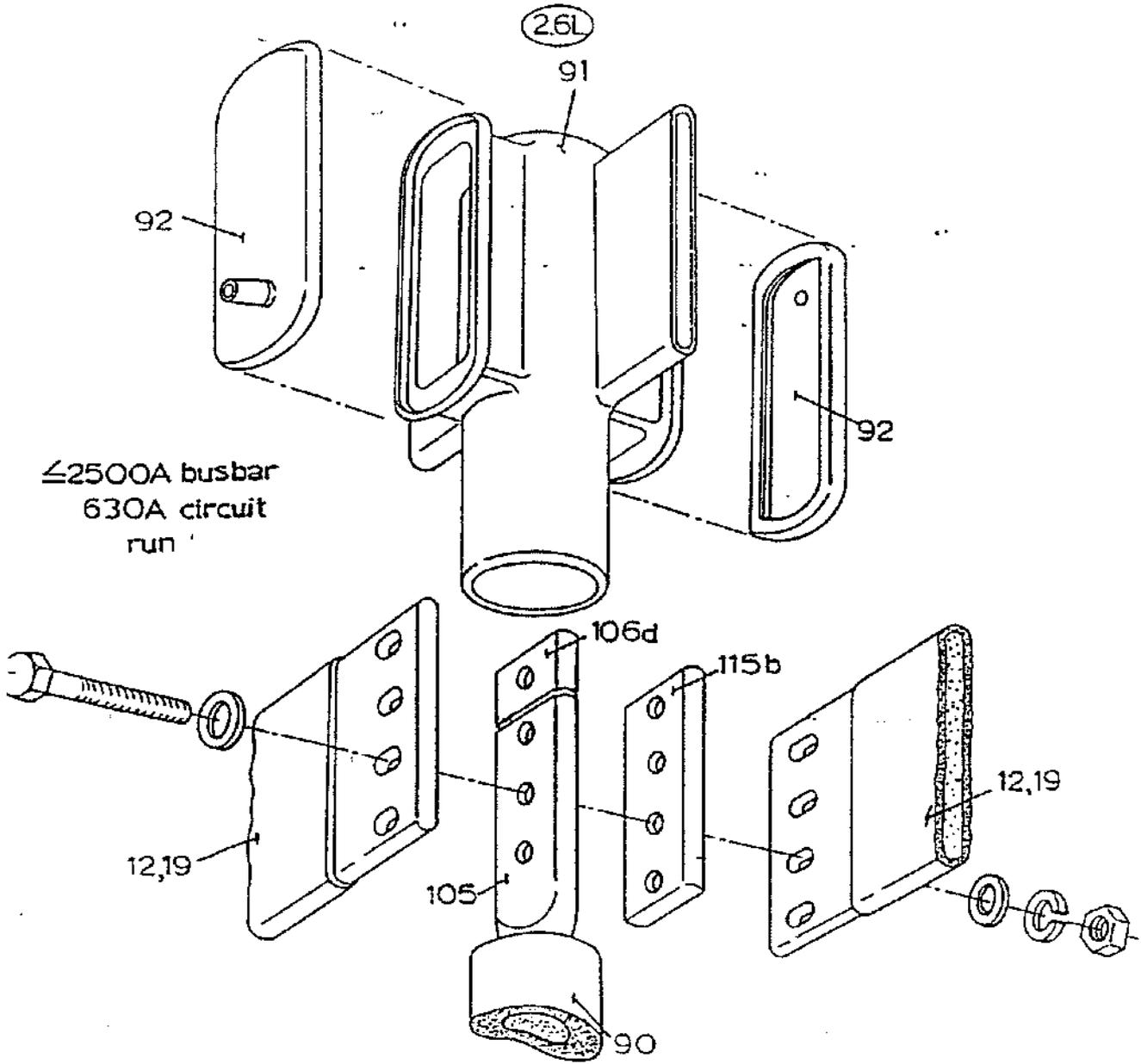

≤2500A busbar  
 630A circuit  
 run

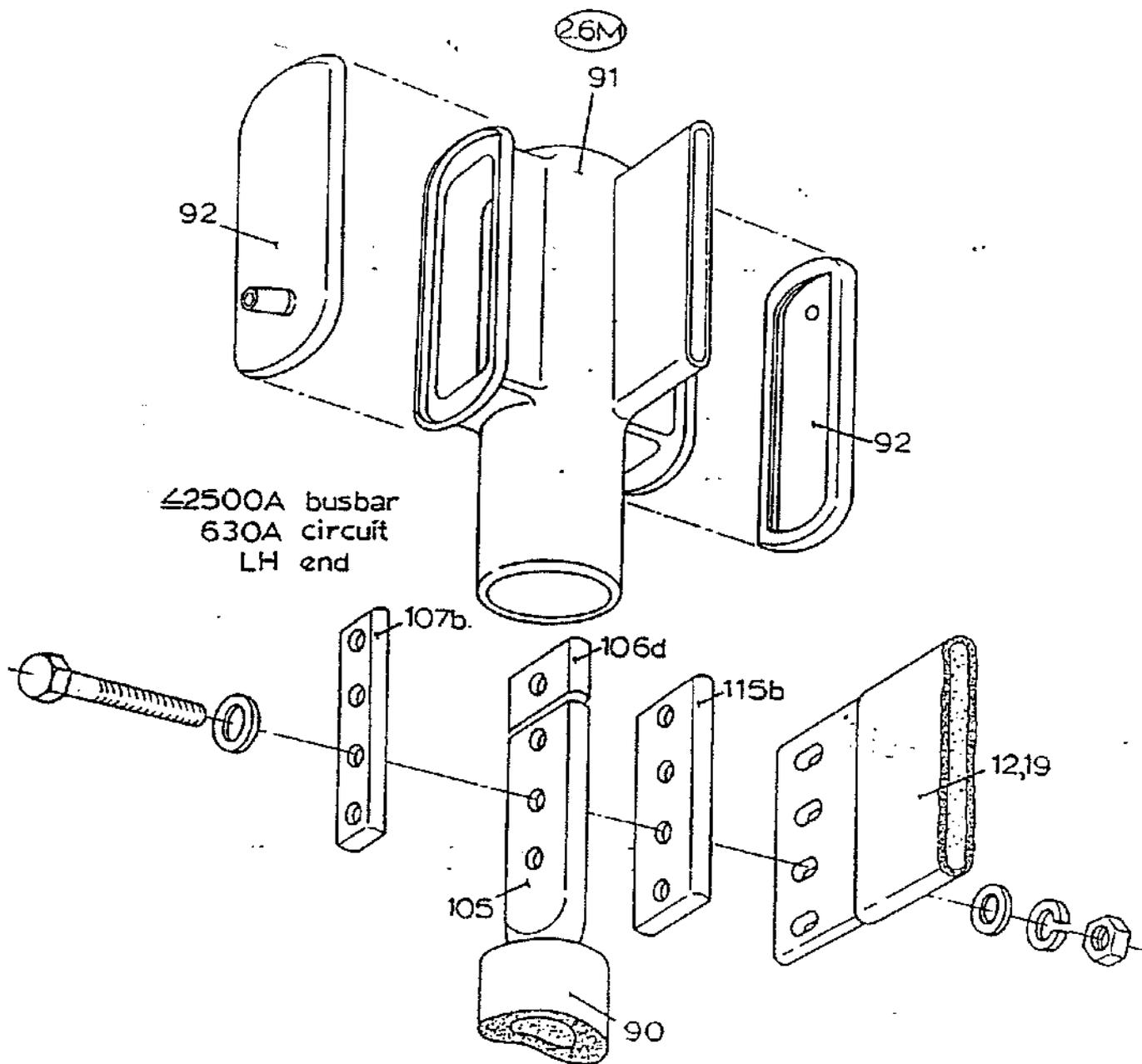

(2.6N)

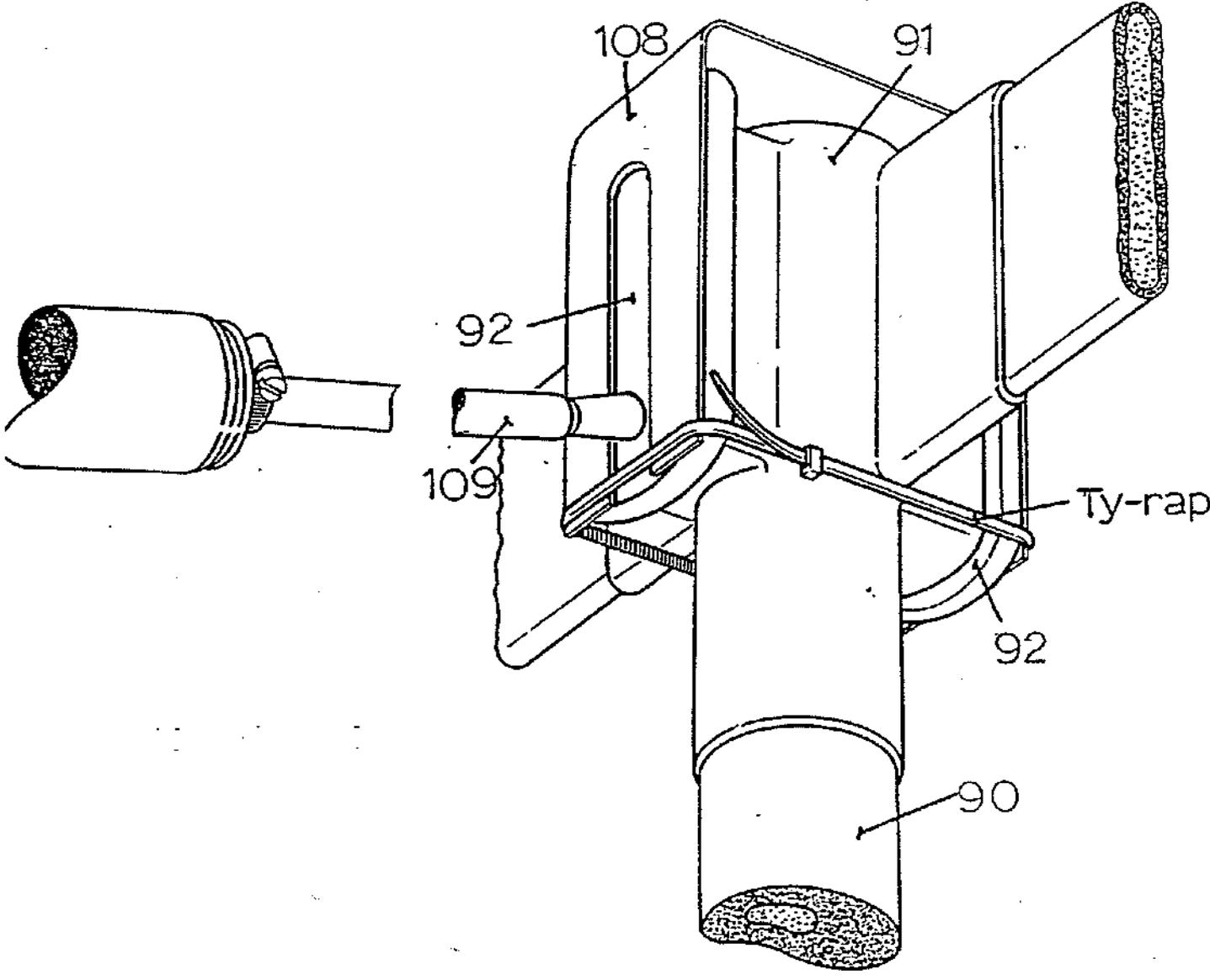

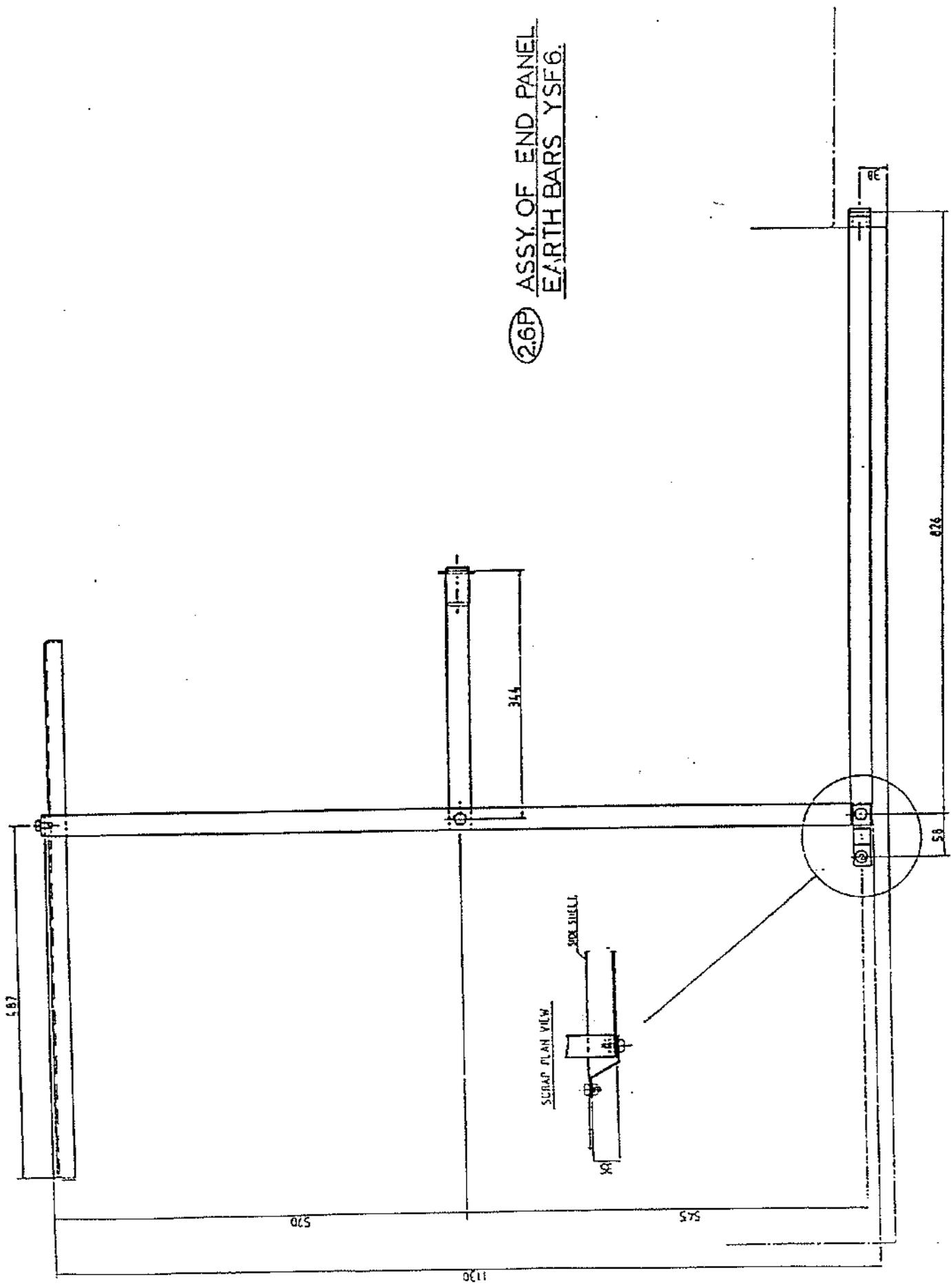

(2.6P) ASSY. OF END PANEL  
EARTH BARS YSF6.

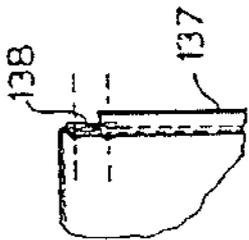
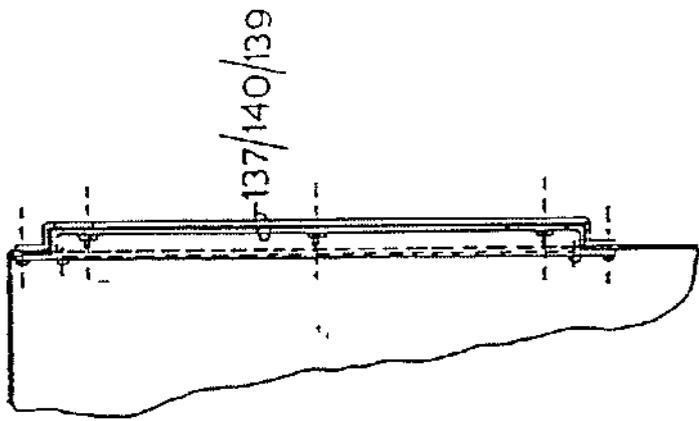
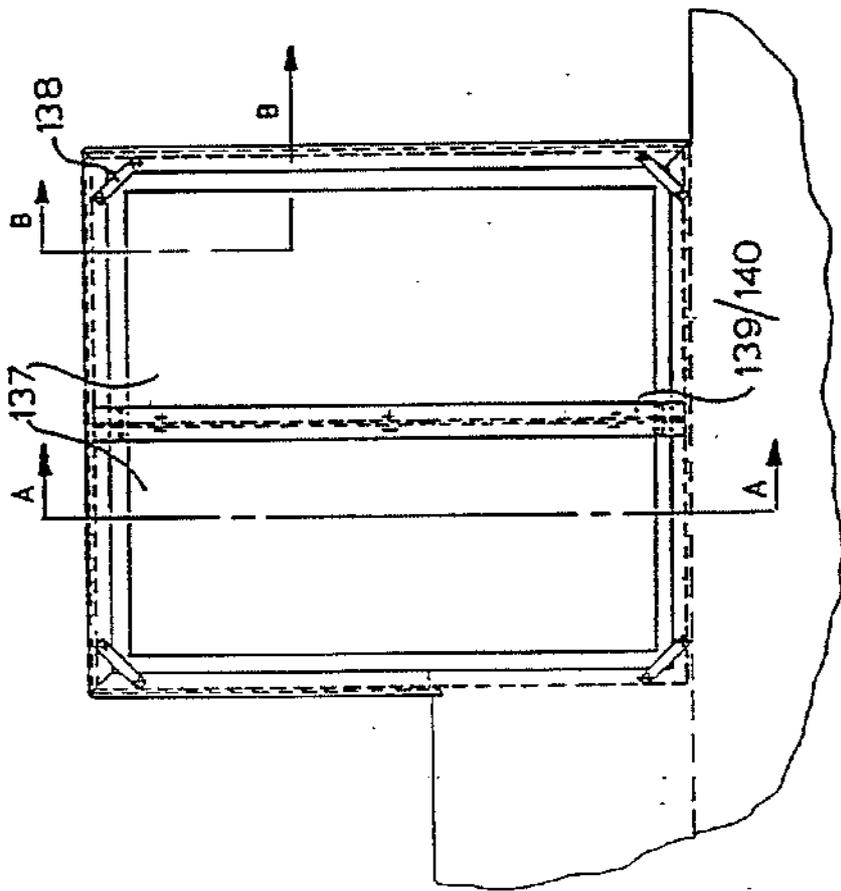

SECTION B-B

2.6R

SECTION A-A

END CAP KIT OF PARTS

## 2.7 Jointing Main Cables

- 2.71 The YSF6 unit incorporates a disconnectable termination system which enables both plastics and paper insulated cables to be connected to the circuit bushing without the need for a bituminous or other compound filling in the cable box.
- 2.72 At the rear of the unit, the current transformer bar primary bushings (89) extend into the cable box (10) where the end of each has a drilled and tapped hole and is tapered in accordance with the American ANSI/IEEE Standard 386 of 1977, and the corresponding European CENELEC specification. Thus, established types of 'elbow' connector can be fitted, as alternatives to the Merlin Gerin termination (110), except in the case of units equipped with feeder voltage transformers.
- 2.73 The Merlin Gerin termination (110) comprises a disconnectable T shaped elastomer 'adaptor', which pushes over the profiled end of the bar primary bushing in much the same way as a conventional elbow connector. However, because the termination will be protected by the earthed metalclad cable box (10), it is not necessary to equip the adaptor with a conducting inner or outer skin. The termination is secured to the tapered bushing end by a nut, spring washer and stud, which are then covered by an insulated sealing plug (111) which may be arranged to incorporate a neon indicator screen.
- 2.74 Where more than one cable must be accommodated on the same phase, one or more extension adaptors (117) can be fitted.
- 2.75 One method of terminating the cable involves the sweating or crimping of a lug (112) to the end of each cable core and then the bolting of the lug to a palm on the bottom extension of the adaptor (110).
- 2.76 Alternatively, where specified, each adaptor (110) can be supplied with a plain stem on the bottom extension. An appropriate ferrule is then crimped both to the cable core end and to the stem. The size and material (copper or aluminium) of the cable cores must be specified in advance so that appropriate ferrules can be provided.
- 2.77 In either case, the heat shrink sleeve (113) or other associated insulation only needs to be applied to the straight cable core, and there is no problem of accommodating the insulation to major irregularities or changes of direction. Precise jointing details will depend on the cable to be employed and on local standards and practices.
- 2.78 The adaptor (110) is fitted to the bushing end (89) as follows:-
- a) Wipe the tapered end of the bushing (89) clean, and brush on a layer of Dow Corning Silicon Grease, type MS4.
  - b) Push the adaptor (110) over the bushing (89). The bushing end should already be fitted with its securing stud.
  - c) Fit the M16 double spring washer and M16 nut supplied on to the stud, using a box spanner and a torque wrench set to 102Nm (75 lbf-ft).
  - d) Brush a layer of the silicon grease onto the taper of the sealing plug (111) and fit the plug into the adaptor end. Screw it home, by hand, until it is solid. There will then be a gap of approximately 1mm between the adaptor and the plug.
  - e) The cable box cover (99) can then be refitted and fastened in place.
- 2.79 Where neon indication has been specified, spring contacts connect the indicator screens in the insulated sealing plugs (111) to neon indicators visible through windows in the cable box cover (99). A weatherproof push button, which protrudes through the cover, completes the circuits from the screens, through the neons and to earth when it is pressed so that, if any cable core is alive, its indicator lights up.

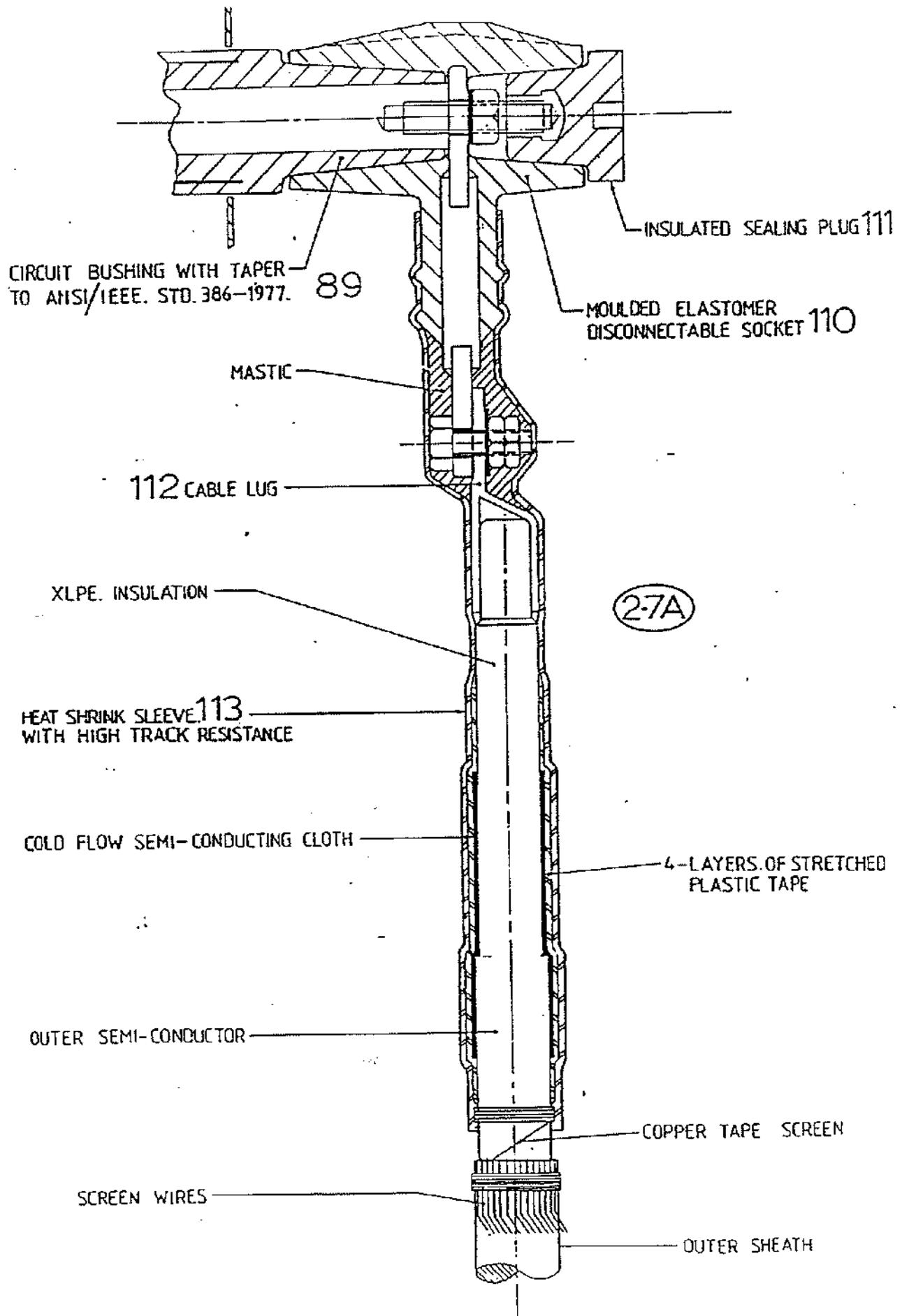

YSF6 FULLY INSULATED DISCONNECTABLE CABLE TERMINATION.

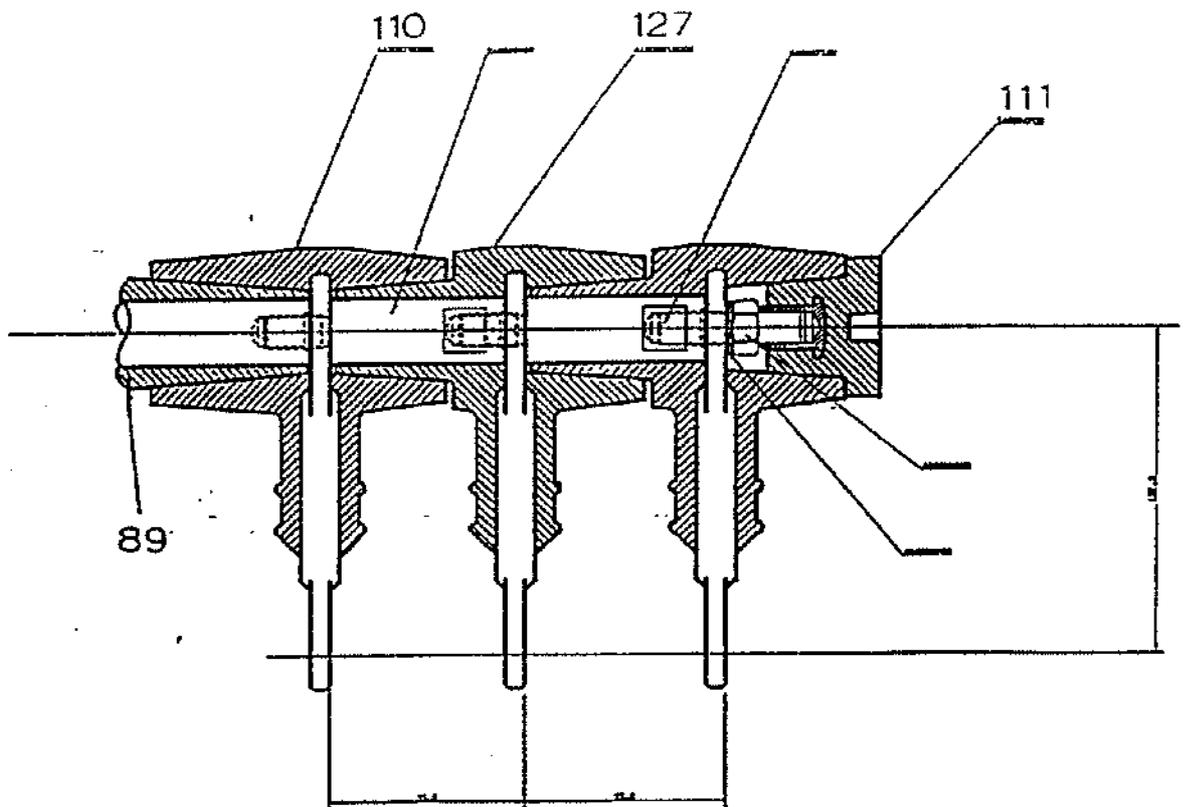

(27B)

YSF6 FULLY INSULATED DISCONNECTABLE  
CABLE TERMINATION. 3-CABLES PER PHASE.

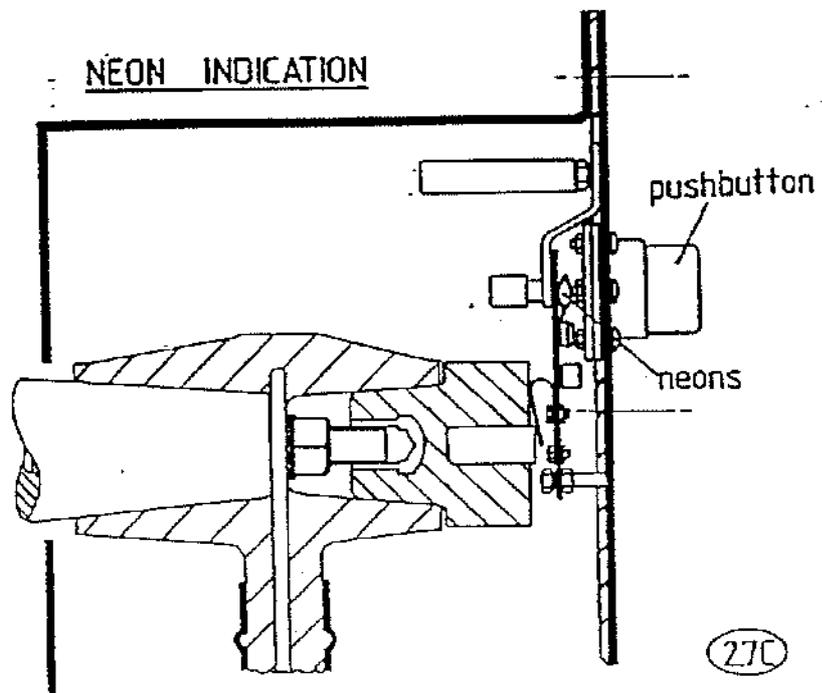

(27C)



### 3. PREPARATION & COMMISSIONING

#### 3.1 Preparation of Fixed Portion

- 3.11 **SAFETY NOTE** The following text assumes that the switchboard has not yet been commissioned and that there is no possibility of the busbars or circuit cable being ALIVE.
- 3.12 Before commissioning the switchboard, check the operation of the safety shutters (15) on each panel. Raise each movable shutter locking lug (71) in turn to line up with its fixed padlocking point, and note that it is now impossible to push open the adjacent shutters. Release the lug (71) and see that it falls freely back to its normal position, releasing the shutters.
- 3.13 A shutter opening device (117) is mounted on the fixed portion left hand side wall adjacent to each pair of shutters (15). With each pair of shutters (15) unlocked and its locking bar (71) in the free, lower position, a sustained push on the end of the adjacent shutter opening device (as indicated on the label plate) will open that pair of shutters and prop them open, giving access to the fixed main isolating contacts (44).
- 3.14 **MAKE SURE THAT ALL FIXED CONTACTS (44) ARE DEAD**, then clean out the receptacle insulators (88) and clean and grease the contacts as described in sub-section 9.4 of this manual.
- 3.15 On completion of cleaning, pull on each shutter opening device (117) in turn, as indicated on its label, to release the shutters which should spring closed.
- 3.16 Check all secondary wiring, paying particular attention to the tightness and security of terminations.
- 3.17 Where a voltage transformer (9) is fitted, check that correctly rated fuses are installed. Check the operation against the instruction plate fastened to the VT housing.
- 3.18 Check for any damaged paintwork. Damaged areas should be cleaned and re-coated as follows:-

Rub down area around the damaged area with medium glass paper. Clean the damaged area with emery paper, ensuring the surface is clean and free of any corrosion. Apply 1 coat of zinc rich epoxy primer (a 2 pack system is recommended), the coating to be 35/45 microns thick. The recommended paint system is International Paints' "Interzinc EPA 072 and EPA 073".

Leave to cure for 24 hours, then apply 2 coats of 2 pack polyurethane to a total thickness of 70/80 microns, i.e. 35/40 microns/coat of Interphane PFR 764.

The standard colours employed are:

Signal red (busbar shutters)	537 (BS.381C)
Lemon yellow (circuit shutters)	355 (BS.381C)
Dark Admiralty Grey	632 (BS.381C)

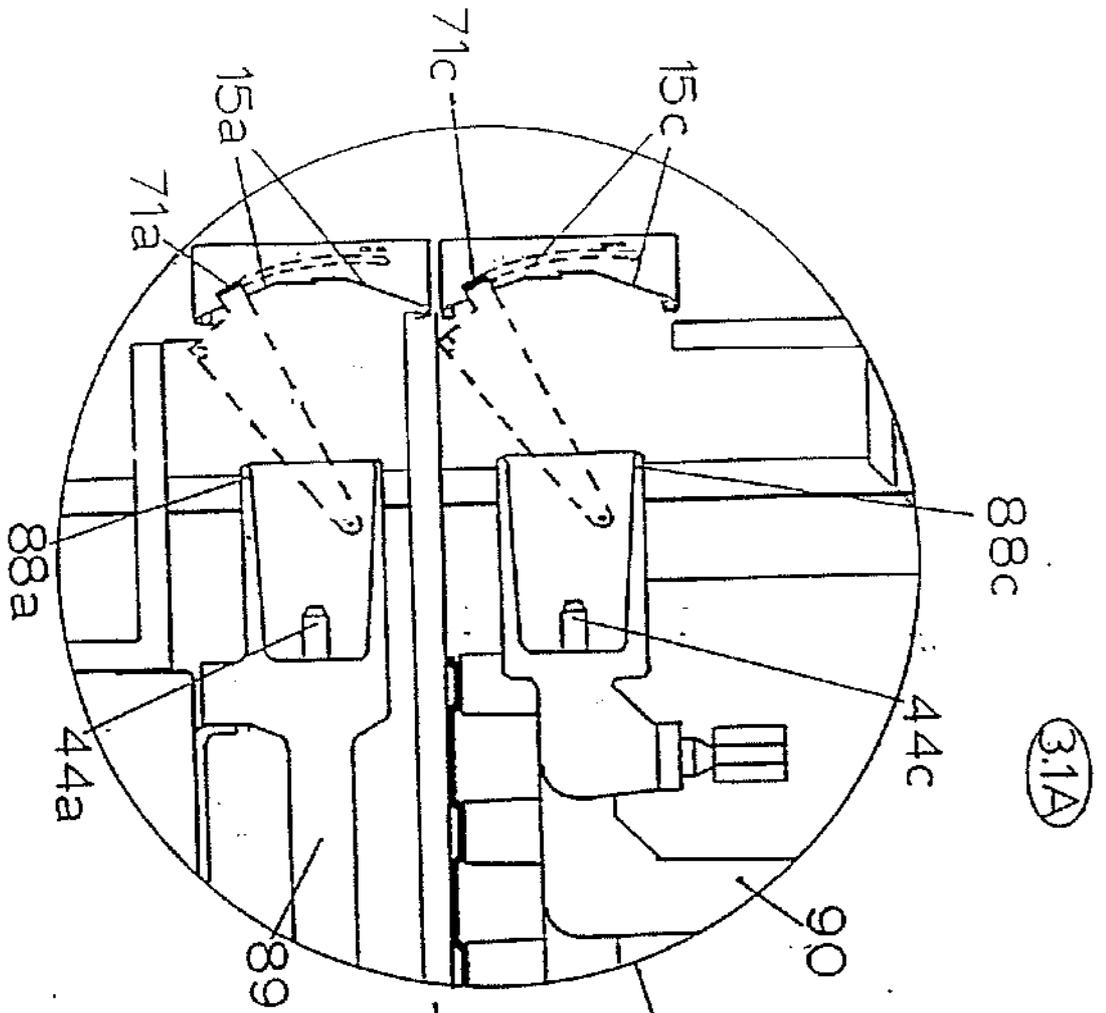

(3.1A)

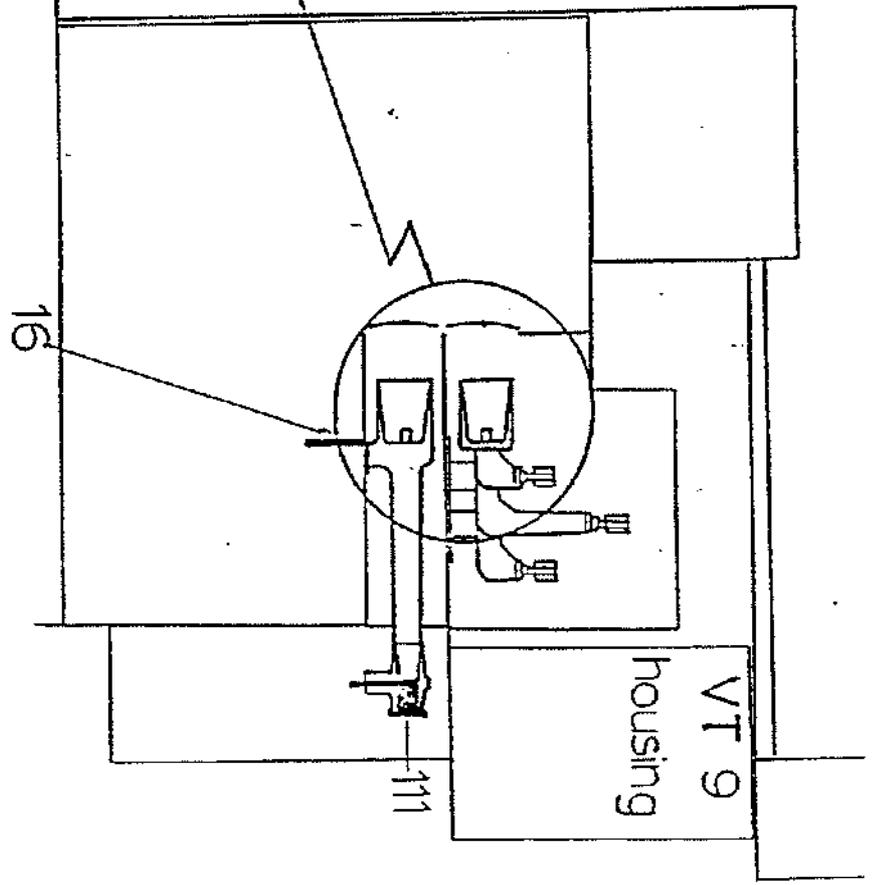

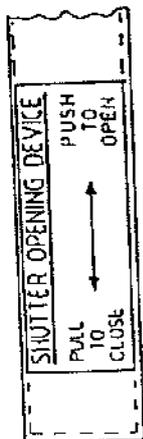

31B

Shutter Opening Device (117)

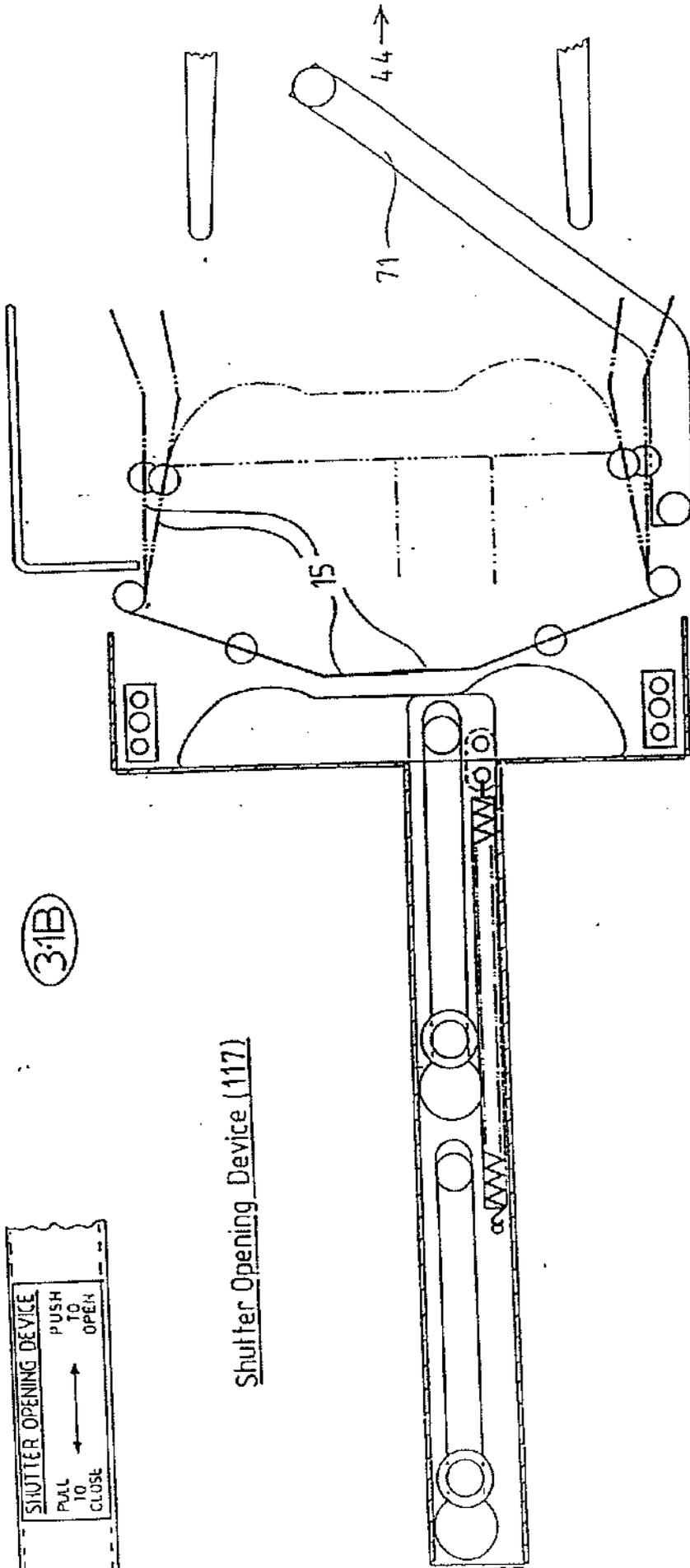

### **3.2 Preparation of Moving Portion**

- 3.21 Remove all packing, labels etc. from the moving portion.
- 3.22 Check the operation of the various interlocks as far as possible against sub-section 1.5 of this manual BEFORE you plug the moving portion into the fixed portion. Then, put each unit in turn through the various mechanical operations described in sections 4 and 5 of this manual.
- 3.23 Touch up any damaged paintwork (see paragraph 3.18 above).

### **3.3 Testing of Protective Equipment**

- 3.31 All protective equipment should be thoroughly tested before commissioning, since the correct operation of circuit breakers on the occurrence of faults is of prime importance, and as relays are called upon to operate only at infrequent intervals, it is essential that they should function in the correct manner.
- 3.32 An operational check can be made on current operated relays by either:
  - (1) Primary injection; (2) Secondary injection; or (3) Current transformer test winding, and the following notes are intended to serve as a guide to indicate the application of these methods.
- 3.33 Protective systems involving relays embodying both current and voltage elements require more complicated testing equipment, and in these cases reference should be made to the manufacturer's literature.
- 3.34 Prior to any operational check the relays should be examined and any packing pieces removed, and all wiring should be checked to diagram.
- 3.35 Primary injection gives the closest simulation of service conditions, since it checks not only the operation of the protective equipment, but also the primary and secondary wiring of the current transformers (CT's). Before carrying out any primary injection testing it is essential to check that none of the CT secondary windings is open circuited, since under this condition all the applied primary ampere turns are employed to magnetise the CT core and dangerously high voltages can be produced.

The unique design of DYSCON dry type cable termination developed for the YSF6 unit makes primary injection testing easy, even if the cables have already been jointed (see sub-section 2.7). The insulated sealing plugs (111) can be unscrewed, and test connections can then be made directly on to the rear ends of the current transformer bushings (89). Access to the fixed isolating contacts (44a) is via the test access device (83) which is pushed in to the open shutters.

Remember to replace the plugs (111) and tighten them fully home (see sub-section 2.7) on completion of testing.

- 3.36 Secondary injection is a useful test for routine operational checks on relay equipment, since the bulky heavy current equipment necessary for primary injection is not required. It is not, however, as complete as Primary Injection Testing since it does not check the accuracy of the CT.

If the relays are provided with a bridge type tapping device, or are of the draw out pattern, secondary injection can readily be carried out by means of split plug type connectors.

3-3A

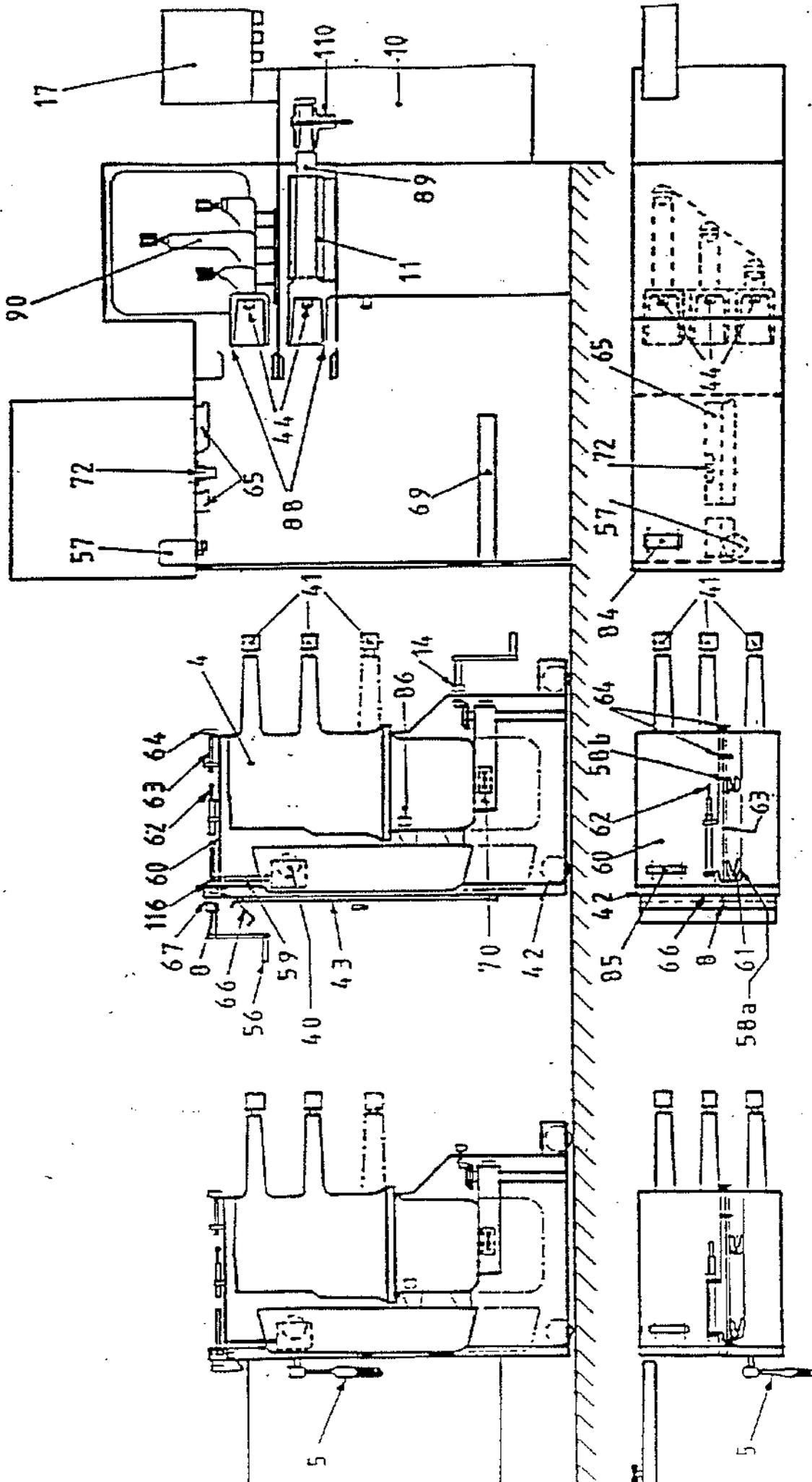

3.37 The duplicate auxiliary drive forks (58a, 58b) mean that the operation of the moving portion secondary circuitry can be tested with the circuit breaker moving portion withdrawn from the fixed isolating contacts (44) and all shutters (15) padlocked closed. The moving portion is pushed part way into the housing until the hold in interlock (8) can be rotated to the horizontal, locked, service position to hold the moving portion fast although the shutters (15) are still closed. The isolating switch (68) is released and the interlock flap (66) can be raised to release the moving portion door (43). A jumper cable with secondary contact blocks can be used to bridge the connections between the fixed (84) and moving (85) secondary contact blocks. The rearmost auxiliary drive fork (58b) will now operate the auxiliary switch (57). All routine circuit breaker operations can now be simulated with the moving portion safely isolated from the distribution network and busbars.

3.38 See also sub-section 4.9

**3.4 High Voltage Tests**

3.41 The application of a high voltage pressure test is often called for, for example, before commissioning or during maintenance of metalclad switchgear, according to local regulations. BS.5227: 1975 specifies the following one minute power frequency test voltages for such site tests:

MAIN CIRCUIT RATED VOLTAGE KV	MAIN CIRCUIT SITE TEST VOLTAGE KV
3.6	8.6
7.2	15.2
12.0	24.0
17.5	32.0
24.0	46.0

Auxiliary circuits: 2.0kV Frequency to be between 16.66Hz and 100Hz.

3.42 The first tests should be applied thus:

- a) all phases to earth with circuit breaker closed;
- b) between phases with circuit breaker closed;
- c) across the break of the open circuit breaker;

3.43 If the equipment is not large enough to produce the correct test voltage, a prolonged test at reduced voltage in accordance with the table below, from BS.5227, may be applied.

POWER FREQUENCY VOLTAGE TESTS FOR DURATIONS EXCEEDING ONE MINUTE (AFTER ERECTION AT SITE)	
Duration of Test Minutes	Percentage of one minute test voltage according to paragraph 3.41
1	100
2	83.5
3	75
4	70
5	66.6
10	60
15	57.7

3.44 D.C Testing:

The use of D.C test sets for cable testing is widespread and the use of this equipment for the pressure testing of switchgear is often convenient. In the event of a D.C voltage test being applied to the switchgear, the values must be in accordance with the table below, from BS.5227, the duration of test to be 15 minutes.

D.C TEST VOLTAGE	
Rated Voltage	Site Test Voltage
kV	kV
3.6	7.5
7.2	15.0
12.0	25.0
17.5	32.0
24.0	45.0

3.45 If high voltage testing of the connecting cable or cables is required once they have been jointed into the switchgear, BS.5227 specifies the following D.C values:-

RATED VOLTAGE OF SWITCHGEAR	*BETWEEN PHASES OF BELTED CABLES	BETWEEN ALL PHASES AND EARTH
kV	kV (D.C)	kV (D.C)
3.6	10.0	7.0
7.2	20.0	15.0
12.0	34.0	25.0
17.5	-	37.0
24.0	-	50.0

\* = With midpoint of test supply earthed.

Note, however, that it is possible to temporarily disconnect the cables if the standard dry-type DYSCON termination is used.

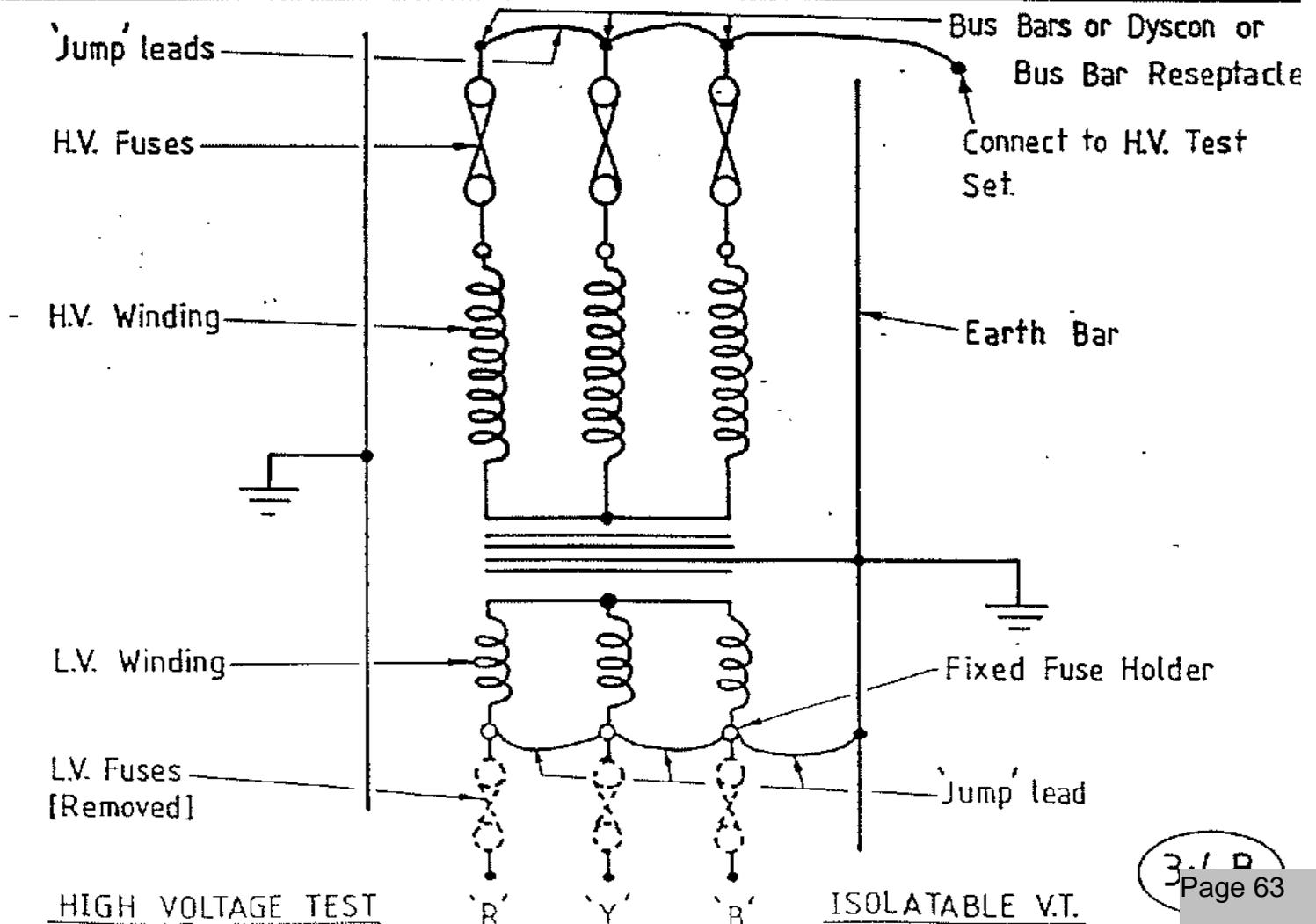
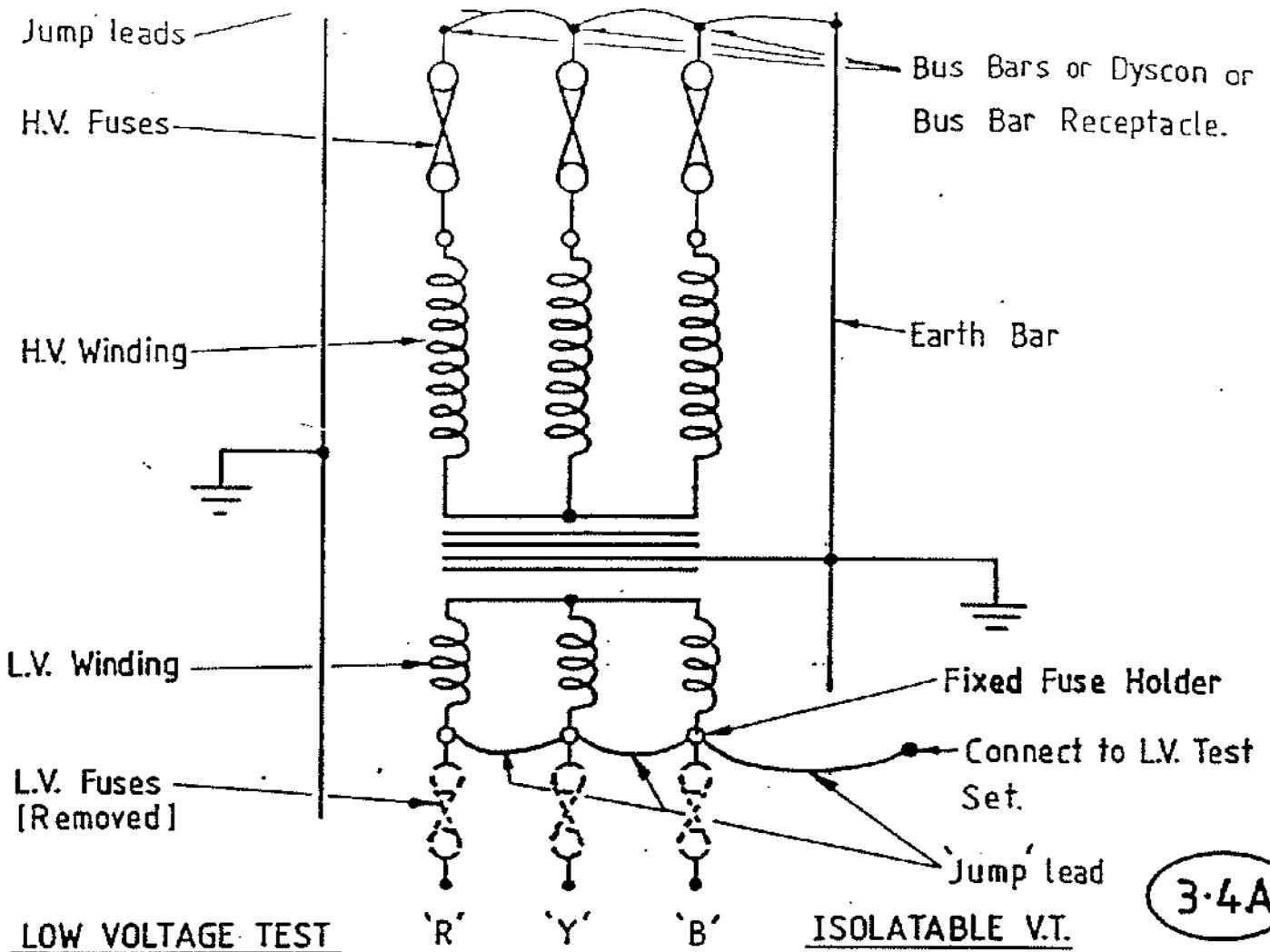



3.46 Site Testing Procedure for Cast Resin Voltage Transformers  
3 Phase 3 Limb Isolatable (YSF6)

3.461 Site testing to be carried out in accordance with:-

BS5227:1994 specification for AC metal enclosed switchgear and control gear for rated voltages above 1kV and up to and including 72.5kV.

BS3941:1975 (1982) specification for voltage transformers.

3.462 The VT may be fitted to the circuit or busbars

1. For the circuit via the cable box Dyscon and circuit bushings.
2. To the busbar moulding via an extended busbar moulding bushing and Dyscon (for VT only).  
The busbars may be upper bus or lower bus.

3.463 CAUTION

It is advisable to carry out high voltage tests before fitting cables. Cables connected by Dyscon connectors may temporarily be disconnected.

All earth bars should be fitted and earthed down before testing refers to BS for health and safety working practises.

3.47 High Voltage Test Transformer in Housing (See Fig 3.4B)

3.471 Primary Insulation Test (Power Frequency)

3.472 The purpose of this test is to check the integrity of the primary insulation systems between the high voltage winding (primary) and the low voltage winding (secondary) and to the core and frame, and any other component intended to be earthed in service.

3.473 Rack VT into 'service' position (NB. with HV fuses fitted). Remove all 6 - LV, fuses and links.

3.474 All the ends of the HV windings must be connected together using 'jump leads'. This can be done at:-

- a) Across the Dyscons in the cable box (cable socket connections)
- b) Across the busbar conductors on the busbar moulding.
- c) Using a test device, inserted into the appropriate CB Iso contacts.

3.475 The 'jump' leads now connected to red, yellow and blue phases should be connected to the HV test set.

3.476 The LV winding terminals should be earthed, using jump leads connected from fuse fixed holder to fuse fixed holder (all 6 fuse fixed holders). The 'jump' leads should be connected to the lower contacts in the fuse fixed holder as these wires emanate from the voltage transformer LV coils (NB. 'jump' leads must not be connected to the upper contacts of the fuse fixed holder as these wires run out to the instrument panel i.e. the LV coils would not be earthed down).

3.477 With all connections made see Fig 3.4B the HV test may now commence. Perform the power frequency withstand test at test voltages according to the voltage transformer transformation ratio in accordance with the table 'A' below.

TABLE 'A'	
Transformer Voltage Ratio	Power Frequency withstand Voltage
4160/110V	20kV
5500/110	20
6600/110	20
7200/110	20
7200/120	20
11000/110	28
12000/110	28
13800/110	36
22000/110	50

FREQUENCY TO BE BETWEEN 16.66Hz and 100Hz  
TEST DURATION 1 MINUTE

TABLE 'B'	
Power Frequency Voltage Tests for Durations exceeding one Minute (After erection at site)	
Duration of test Minutes	Percentage of one-minute test voltage according to Table **
1	100
2	83.5
3	75
4	70
5	66.6
10	60
15	57.7

### 3.48 Secondary Insulation Test

3.481 Low voltage power frequency test (See Fig 3.4A).

3.482 With the VT in the 'service' position all three phases red, yellow and blue of the HV coils must be connected together and down to earth. Use a test device, inserted into the appropriate CB Iso contacts.

3.483 Using 'jump' leads connect all 6 fuse fixed holders together. The 'jump' leads should be connected to the lower contacts in the fuse fixed holder as these wires emanate from the voltage transformer LV coils. (NB. 'jump' leads must not be connected to the upper contacts of the fuse fixed holder as these wires run out to the instrument panel i.e. the LV coils would not be energised at 2kV).

3.484 Now connect the LV 'jump' leads to the test set. Perform the secondary winding insulation test by applying 2kV to the LV windings. Test duration 1 minute.

### **3.5 Making Alive**

- 3.51 With all circuit breaker moving portions isolated, switch on any auxiliary circuits which may be required for indication and control. Operate the switchgear as follows, in accordance with sections 4 and 5 of this manual.
- 3.52 Plug in a circuit breaker moving portion to the circuit which is to provide the incoming supply. Make that supply alive from the remote end. Close, trip and reclose the local circuit breaker. Check the operation of any indicating or measuring instruments.
- 3.53 Plug in and close/trip/close at each of the other panels in turn as the circuits are ready for commissioning. Check the operation of instruments at each panel in turn then, in the case of motorised units, leave the AUTO/OFF control set to AUTO.

#### **4. MOVING PORTION ISOLATION SYSTEM**

##### **4.1 To Plug the Moving Portion into the Service Position**

- 4.11 The moving portion will be withdrawn from the switchboard. Note that the circuit breaker is OFF. Note whether the circuit breaker module is in the raised (3) or lowered (2,18) position. (Not applicable in the case of non-elevating earthing trucks).
- 4.12 Should the breaker be in the wrong vertical position, fit the winding handle (56) into its socket (14) at the back of the moving portion and wind anti-clockwise to lower, or clockwise to raise, the unit. Wind until the breaker is at the fully raised or fully lowered position.
- 4.13 With the unit fully raised or lowered, check that the door (43) is closed, lower the interlock flap (66) and set the isolating selector (8) to its vertical FREE position. Check that the fixed portion feeder shutters (15a) and appropriate busbar shutters (15b or c) (except when transfer earthing) are not locked, and that their shutter locking bars (71a, b or c) are down into their lowered positions. Check also that the shutters of the contacts NOT to be used ARE padlocked closed.
- 4.14 Grip the curved 'handle' portion of the interlock flap (66) with both hands and push the moving portion firmly but slowly towards the fixed portion, until the horizontal hold-in block (64) is stopped by the front end of the main angled section of the fixed portion hold-in interlock bracket (65). Move the isolating selector (8) to the angled position at which the block (64) clears the bracket (65). Begin to push the moving portion once more, until the block (64) is again stopped by the farthest section of the bracket (65). By now, the shutters will be open and the moving main isolating contacts (41) will be about to engage the appropriate fixed contacts (44a, b or c or 16).
- 4.15 Fit the long winding handle (56) into the socket at the front end of the isolating screw (62), through the hole in the front panel adjacent to the isolating selector (8). Wind the handle clockwise to move the moving portion the last few centimetres and mate the main isolating contacts (41, 44). When the handle stops solid, remove it and pivot the isolating selector (8) to its horizontal LOCKED position. If you cannot do this, the unit is not fully home and further turns of the winding handle should be possible. The isolating selector can be padlocked in the horizontal position if required to prevent unauthorised isolation of the moving portion.
- 4.16 Lift the interlock flap (66) to give access to the door (43) and thence the mechanism. The breaker may now be charged and closed, or the 'CLOSE' lever (49) may be padlocked to prevent closure, as required.

##### **4.2 To Withdraw the Moving Portion from the Fixed Portion**

- 4.21 Note that the circuit breaker is OFF and lower the interlock flap (66) to give access to the isolating selector (8).
- 4.22 Pivot the selector (8) to the angled position, to give access to the socket at the front end of the isolating screw (62), and fit the long winding handle (56) to the screw socket. Wind the handle anti-clockwise to move the moving portion towards you and pull the isolating contact clusters (41) clear of the fixed isolating contacts (44 or 16).
- 4.23 When the handle revolves freely and the moving portion stops moving, remove the handle (56) and hook your fingers behind the curved handle portion of the interlock flap (66) and pull the moving portion towards you. If it will not move, you have now wound the isolating screw (62) fully clear of its screwed block (72) in the fixed portion.
- 4.24 Continue to pull the moving portion forwards until the hold-in block (64) clears the angled portion of the hold-in interlock bracket (65). At this point the isolating selector may re-align itself to the vertical position of its own accord, in which case you can continue to pull the moving portion forwards until it is clear of the fixed portion housing. If the selector does not re-align itself, the block (64) will come up against the back of the foremost section of the bracket (65), and the selector must be moved by hand to the vertical position so that the moving portion can be withdrawn completely.

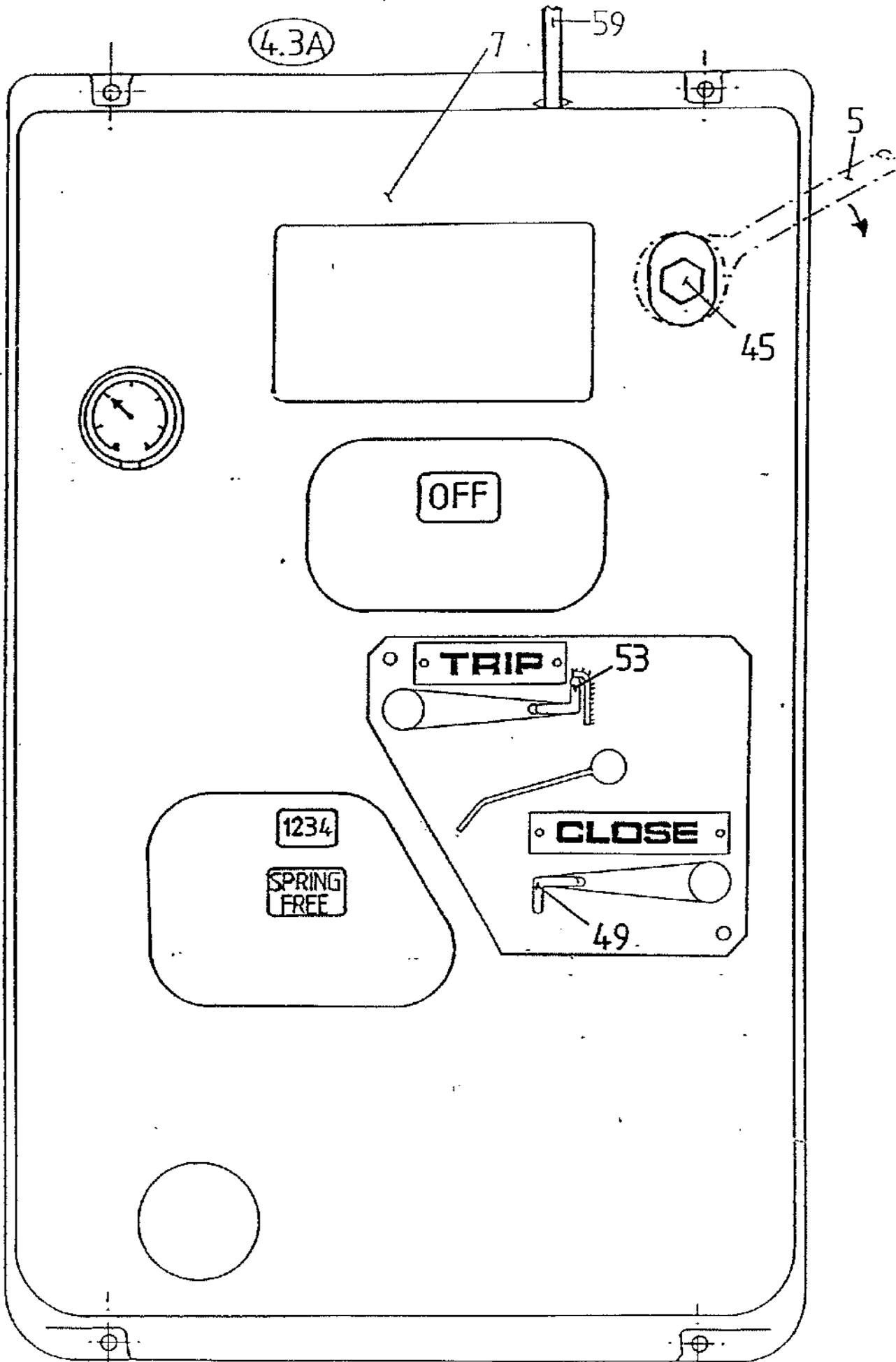

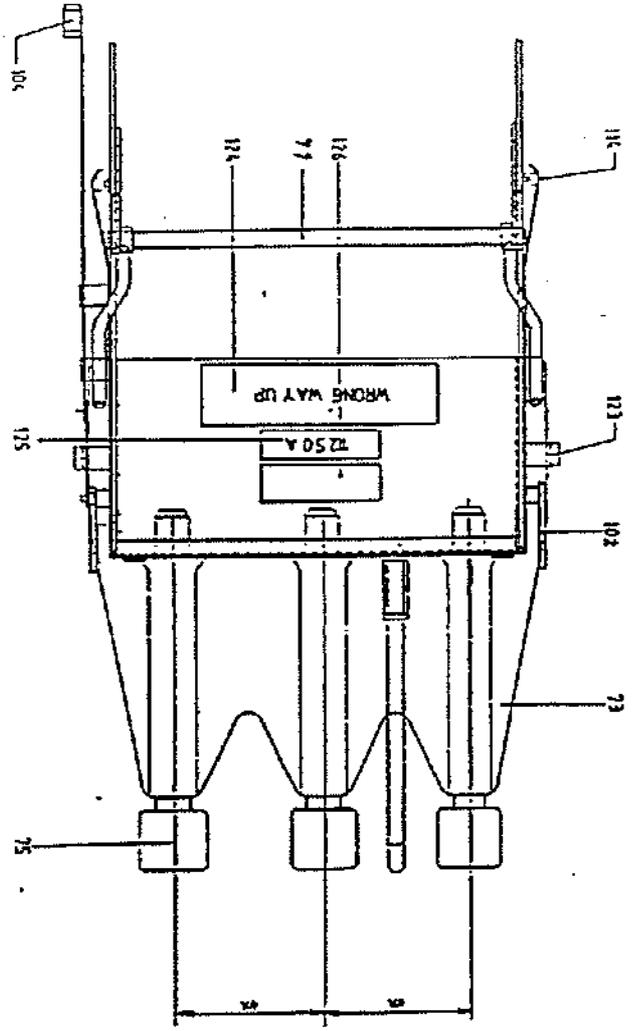
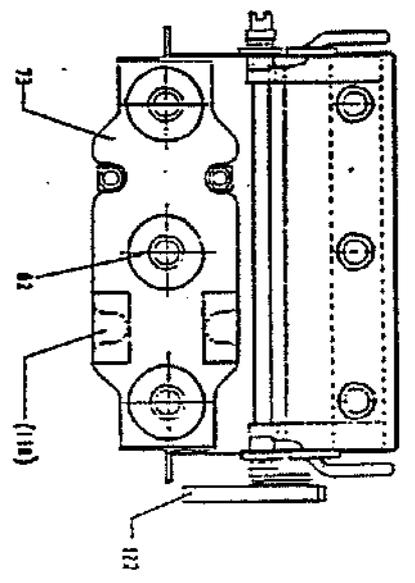
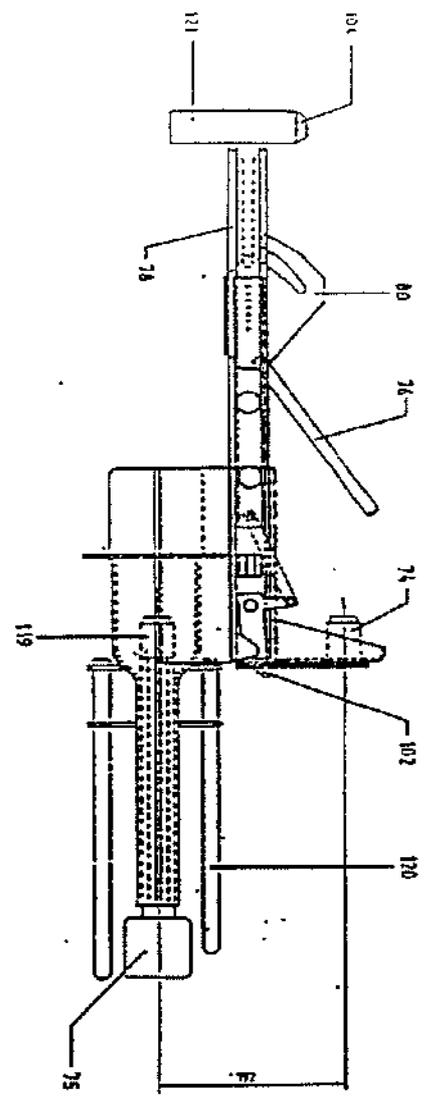

YSF6 1250A EARTHING DEVICE

4.4A

TO MOUNT THE PORTABLE EARTHING DEVICE ONTO THE MOVING PORTION.

1. CHECK RATING, SELECT EARTHING POSITION REQUIRED.

4.4B

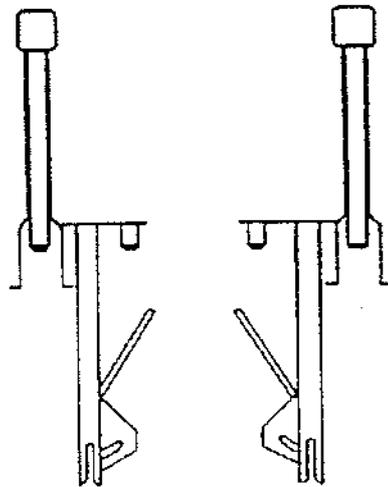

2. OFFER DEVICE ONTO MOVING PORTION ENGAGING GUIDE FORKS ON LOCATING PINS.

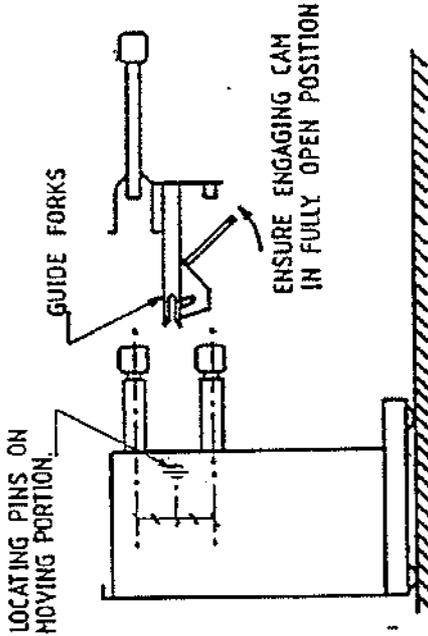

3. CLOSE ENGAGING CAM OVER TOGGLE, ENSURE SELECTOR KNOB IN "FREE" POSITION AND RELEASE KNOB IN "VERTICAL" POSITION. MOVING PORTION READY TO OFFER INTO FIXED PORTION.

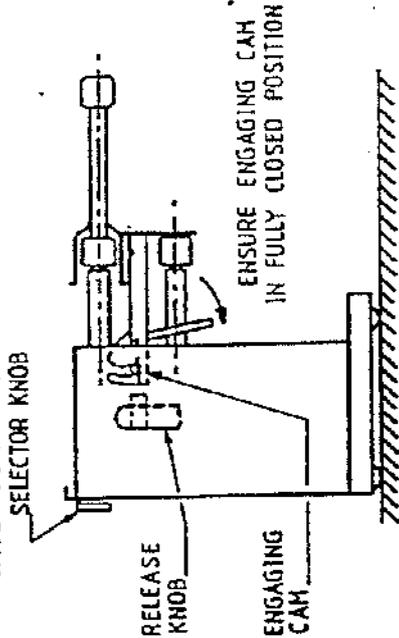

TO REMOVE MOVING PORTION WITH EARTHING DEVICE FITTED FROM FIXED PORTION.

- ENSURE SELECTOR KNOB IN "FREE" POSITION, TURN EARTHING DEVICE RELEASE KNOB THROUGH 90° PROPPING TOP FACE AGAINST FIXED PORTION FRONT FLANGE AND WITHDRAW MOVING PORTION.

4.4C

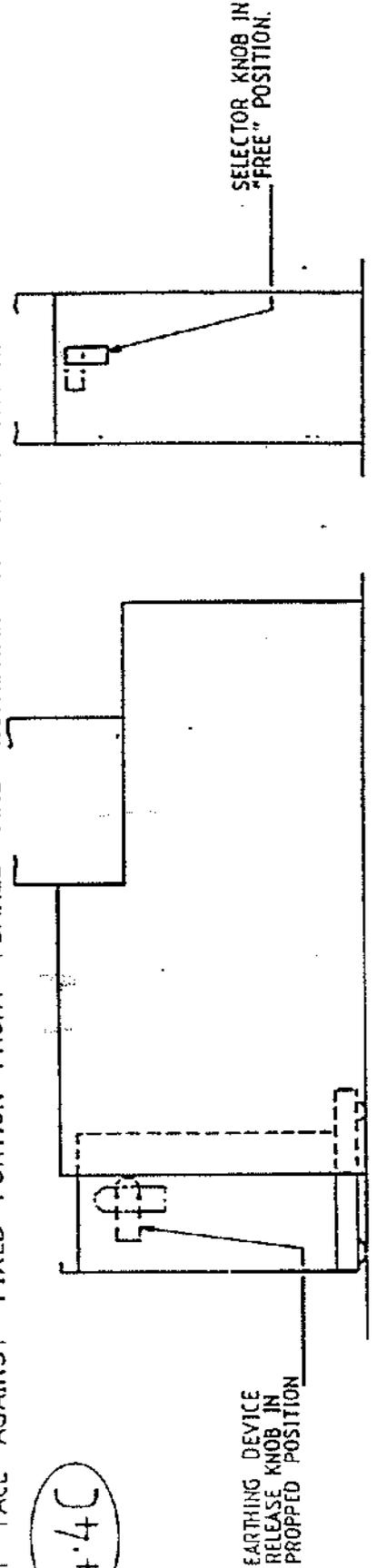

4.25 The feeder (15a) and busbar (15b, 15c) shutters can be padlocked closed by means of their respective shutter locking lugs (71a, 71b, 71c).

#### 4.3 Transfer Earthing of the Circuit Cable

4.31 Before earthing any circuit, ensure that it has been made dead, isolated and locked off from all possible points of supply. Where a fixed portion is equipped for transfer earthing of the circuit, this is achieved by lowering the circuit breaker and plugging it in as described in sub-section 4.1. The circuit breaker is then charged and closed as described in section 5, and the manual trip lever/button (53) is padlocked to prevent unauthorised removal of the earth.

4.32 Moving portions supplied with transfer-earth-equipped switchboards incorporate a micro switch (87) which automatically disconnects the electrical trip circuit when the circuit breaker module is in the transfer earth position. This ensures that an earth applied through the transfer earthing system is secure.

#### 4.4 Earthing the Circuit or Busbars through the Portable Earthing Devices: General

4.41 Either the circuit cable, the lower busbars or the upper busbars can be earthed through the circuit breaker by means of portable earthing devices (55) which mount on the moving main isolating contact clusters (41) of the moving portion. Both the earthing devices and the circuit breaker are designed to carry the full rated short circuit current without stress. This means that if an earth is mistakenly applied to live contacts, or if a set of earthed contacts is made alive from another source, the safety of the operator is assured. Circuit earthing devices are painted yellow, busbar earthing devices are painted red. Labels indicate their right way up for use.

4.42 Before earthing any circuit or busbar system, ensure that it has been made dead, isolated and locked off from all possible points of supply. At the panel where the earth is to be applied, the safety shutters (15a, b or c) of the contacts which are not to be earthed must be padlocked closed by means of the appropriate locking (bars) (71a, b or c).

#### 4.5 To Fit the Yellow Earthing Device for Feeder Circuit Earthing

4.51 With the moving portion withdrawn from the fixed portion, and the circuit breaker OFF and wound down (see paragraph 4.12), stand between the fixed and moving portions and hold the yellow earthing device horizontal, so that its glass reinforced plastic (GRP) moulding (73) is uppermost, the earthing star point contacts (74) are at the bottom, and the contact clusters (75) are pointing towards the feeder circuit safety shutters (15a).

4.52 Make sure that the locking handle (76) is in its horizontal, unlocked position.

4.53 Offer the device to the moving portion so that the horizontal operating shaft (77) passes between the upper and lower moving portion contact clusters (41a and b) and their bushings, and the 'spouts' (82) formed by the earthing device GRP moulding (73) envelope the upper set (41a) of moving portion contact clusters.

4.54 Push the device home so that the securing forks (78) at each side engage the earthing bosses (81) on the sides of the moving portion.

4.55 Rotate the earthing device locking handle (76) so that the claw cams (80) also engage the bosses (81) on the sides of the moving portion, and so pull the device firmly into engagement with the moving portion contact clusters (41). At the same time the earth wipe contacts (114) will rub against the earthing bars (79) on the sides of the moving portion.

4.56 Check that the earthing device contact clusters (75) are in line with the unlocked feeder circuit shutters (15a), whose locking bar (71a) is folded down into its horizontal position.



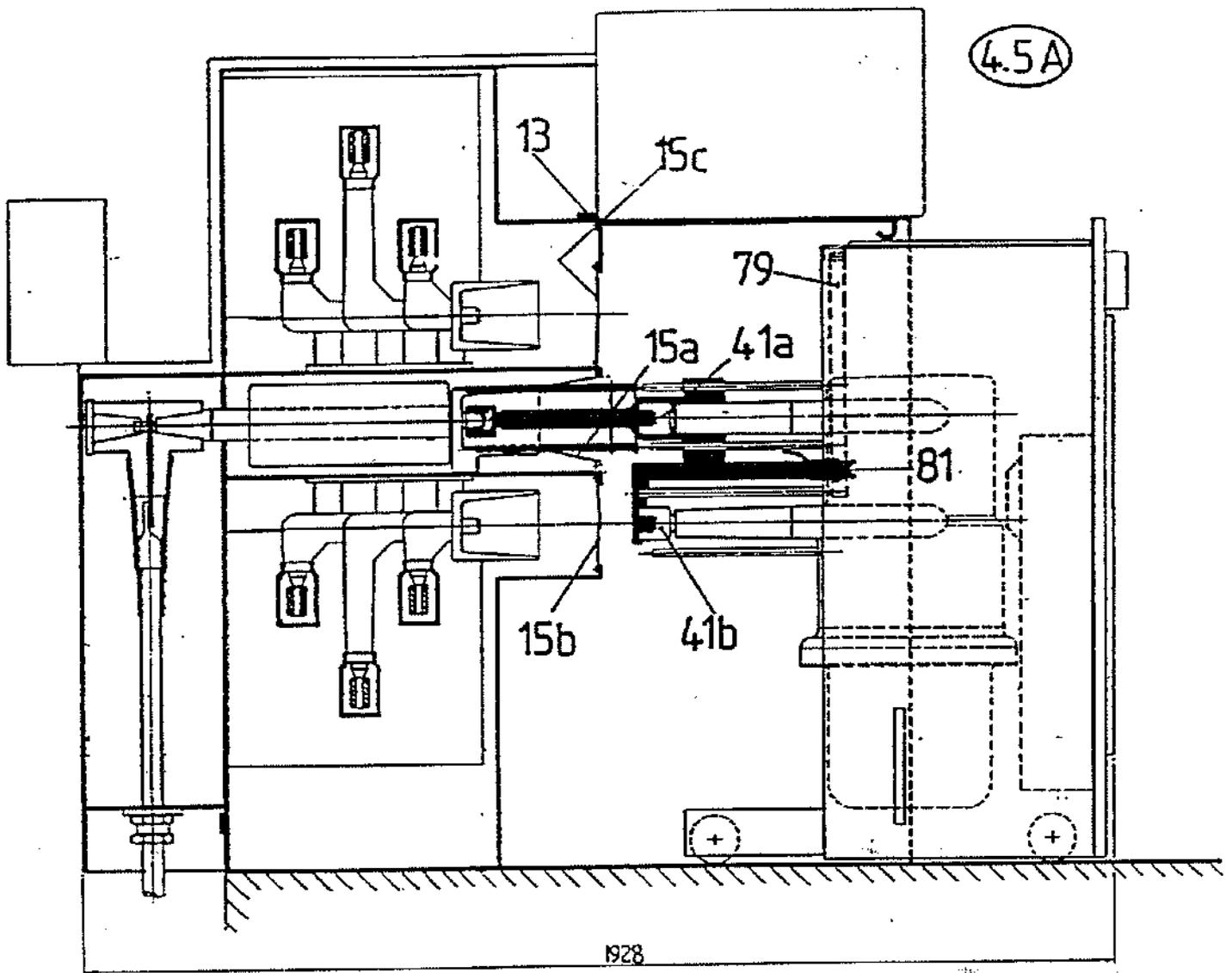

4.5A

YSF6 circuit earthing

#### **4.6 To Fit the Red Earthing Device for Upper Busbar Earthing**

- 4.61 With the moving portion withdrawn from the fixed portion, and the circuit breaker OFF and wound up (see paragraph 4.12), stand between the fixed and moving portions and hold the red earthing device horizontal, so that its glass reinforced plastic (GRP) moulding (73) is at the top, the earthing star point contacts (74) are lower, and the contact clusters (75) are pointing towards the upper busbar safety shutters (15c).
- 4.62 Make sure that the locking handle (76) is in its horizontal, unlocked position.
- 4.63 Offer the device to the moving portion so that the horizontal operating shaft (77) passes between the upper and lower moving portion contact clusters (41a and b) and their bushings, and the 'spouts' (82) formed by the earthing device GRP moulding (73) envelope the upper set (41b) of moving portion contact clusters.
- 4.64 Push the device home so that the securing forks (78) at each side engage the earthing bosses (81) on the sides of the moving portion.
- 4.65 Rotate the earthing device locking handle (76) so that the claw cams (30) engage the bosses (81) on the sides of the moving portion, and so pull the device firmly into engagement with the moving portion contact clusters (41). At the same time, the earth wipe contacts (114) will rub against the earthing bars (79) on the sides of the moving portion.
- 4.66 Check that the earthing device contact clusters (75) are in line with the unlocked upper busbar shutters (15c), whose locking bar (71c) is lowered.

#### **4.7 To Fit the Red Earthing Device for Lower Busbar Earthing**

- 4.71 With the moving portion withdrawn from the fixed portion, and the circuit breaker OFF and wound down (see paragraph 4.12), stand between the fixed and moving portions and hold the red earthing device horizontal, so that its glass reinforced plastic (GRP) moulding (73) is at the bottom, the earthing star point contacts (74) are higher, and the contact clusters (75) are pointing towards the lower busbar safety shutters (15b).
- 4.72 Make sure that the locking handle (76) is in its horizontal, unlocked position.
- 4.73 Offer the device to the moving portion so that the horizontal operating shaft (77) passes between the upper and lower moving portion contact clusters (41a and b) and their bushings, and the 'spouts' (82) formed by the earthing device GRP moulding (73) envelope the lower set (41c) of moving portion contact clusters.
- 4.74 Push the device home so that the securing forks (78) at each side engage the earthing bosses (81) on the sides of the moving portion.
- 4.75 Rotate the earthing device locking handle (76) so that the claw cams (30) engage the bosses (81) on the sides of the moving portion, and so pull the device firmly into engagement with the moving portion contact clusters (41). At the same time, the earth wipe contacts (114) will rub against the earthing bars (79) on the sides of the moving portion.
- 4.76 Check that the earthing device contact clusters (75) are in line with the unlocked lower busbar shutters (15b) whose locking bar (71b) is lowered.

#### **4.8 Plugging in and Withdrawing the Moving Portion with the Earthing Device Fitted**

- 4.81 With the appropriate sets of shutters locked and unlocked, the earthing device mounted on the moving portion in the appropriate attitude, the circuit breaker open and the moving portion raised or lowered as required, close the moving portion door (43), lower the interlock flap (66) and set the black isolating selector (8) to its vertical FREE position.

POSITION B

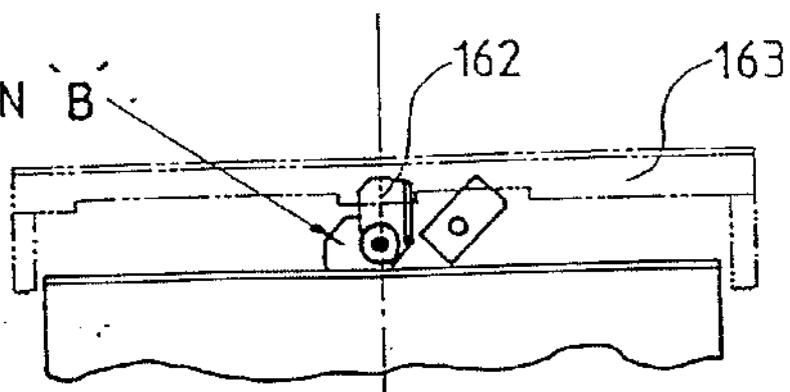

4-8B

POSITION A

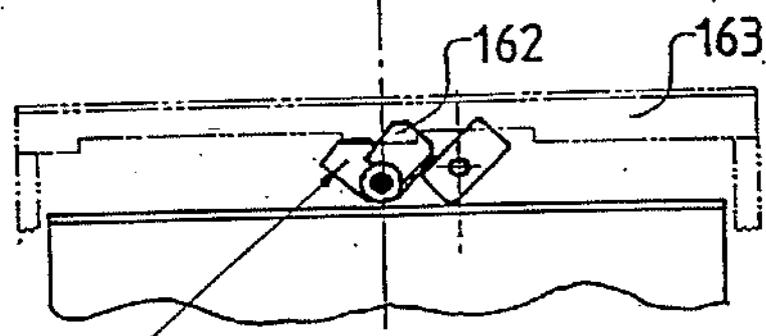

- 164
- 158
- 159
- 155
- 161
- 62
- 156
- 85

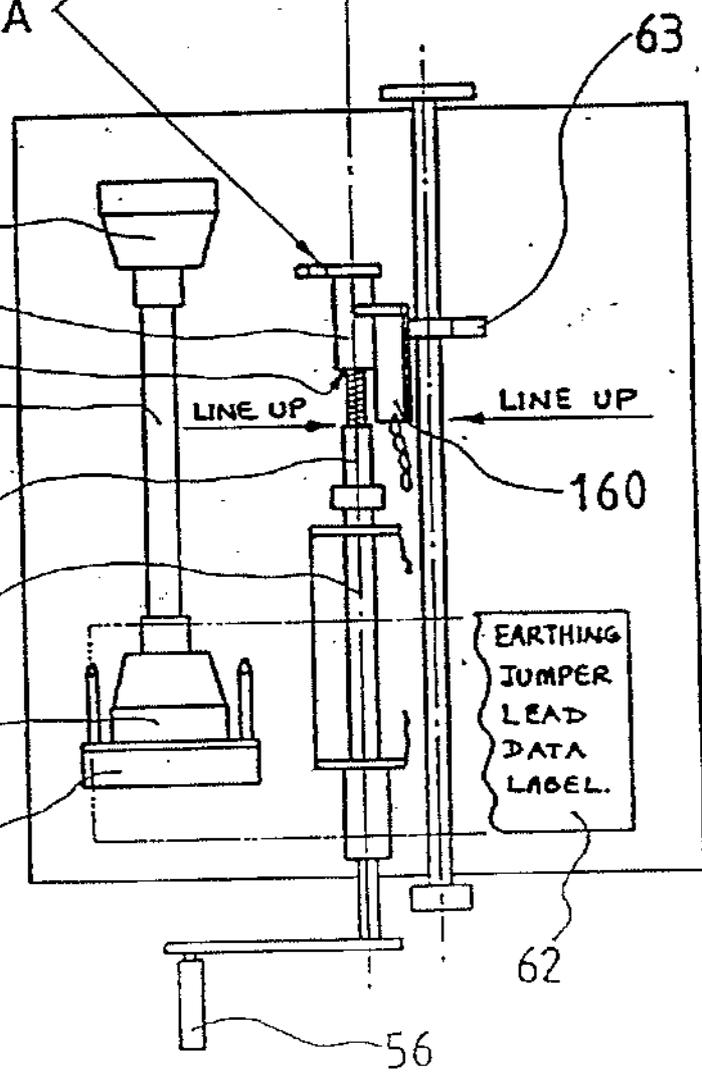

4-8A

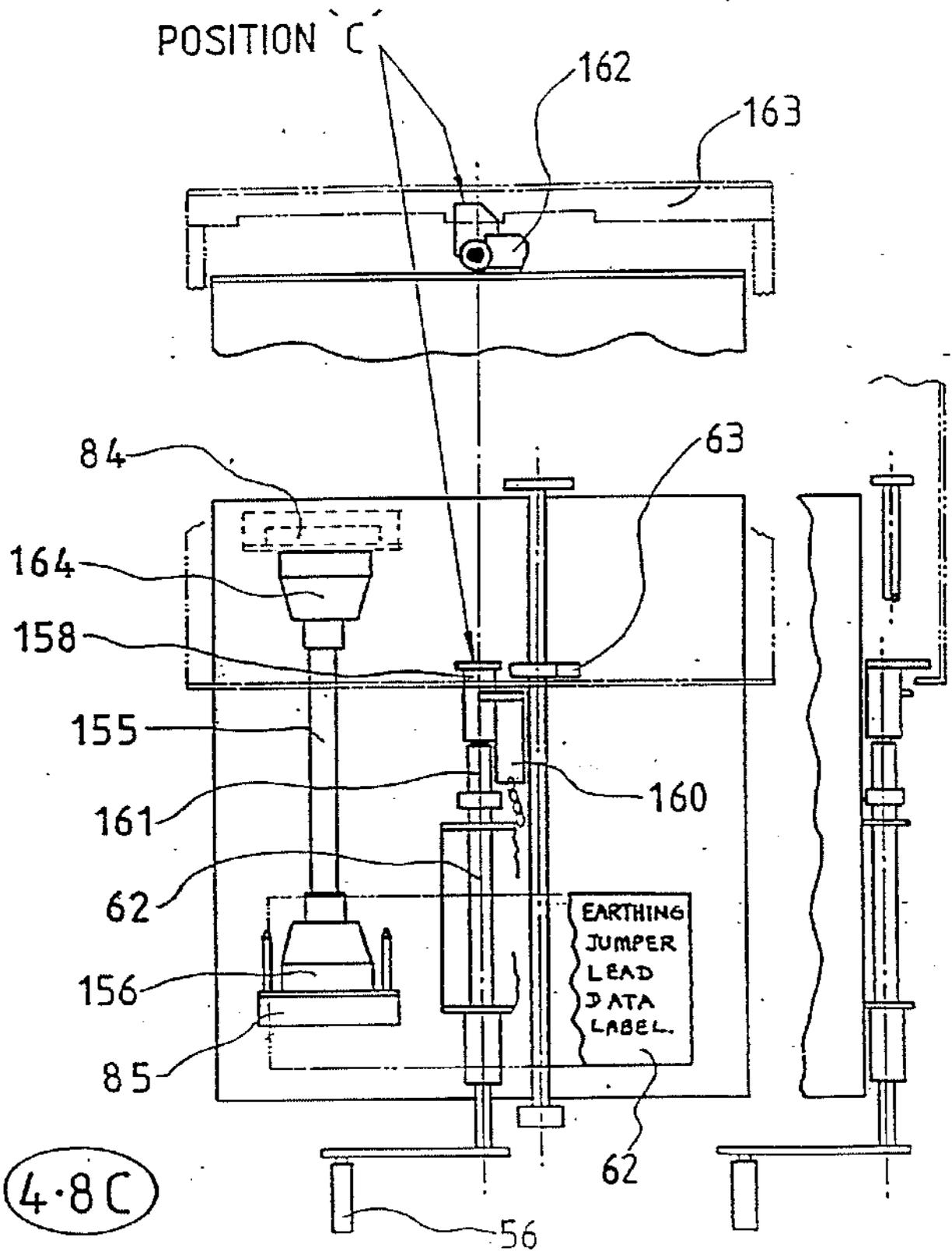

- 4.82 Place the earthing jumper lead assembly (155) on top of the moving portion carriage, engaging the secondary contact block (156) on the underside of the jumper lead plate (157) with that (85) on the moving portion.
- 4.83 Insert the long winding handle (56) into the socket at the end of the isolating screw (62) and place the racking-in device (158), which is secured to the plate (157) by a short length of chain, on top of the moving portion so that it rests against the angled front hold-in block (63). Turn the handle (56) clockwise to screw the isolating screw (62) into the tapped hole (159) in the racking in device (158), until the edge of the device's flat plate (160) nearest to you is aligned with the shoulder (161) at the end of the isolating screw thread. (Position 'A').
- 4.84 Turn the racking in device (158) to the left, so that the block (162) is vertical (Position 'B'). Grip the curved 'handle' portion of the interlock flap (66) with both hands and push the moving portion firmly but slowly towards the fixed portion, until the block (162) is stopped by the vertical front edge (163) of the fixed portion housing top plate. Turn the winding handle (56) clockwise, so that the racking in device (158) first rotates to Position 'C', then pulls the moving portion into the housing. Continue to turn the handle (56) until it will turn no further.
- 4.85 During the foregoing operations, the shutters will have been pushed open and the earthing device contact clusters (75) will have passed through them and engaged the appropriated fixed main isolating contacts (44a or 44b). At the same time, securing hooks (102) on the earthing device will have engaged bosses (103) on the fixed portion sidewalls, to hold the device and the moving portion securely plugged in.
- 4.86 When the contacts are securely engaged, the horizontal hold-in block (64) will be up against the front edge of the main angled section of the fixed portion hold-in interlock bracket (65). Remove the winding handle (56) and move the black isolating selector (8) to the horizontal LOCKED position.
- 4.87 Plug the secondary isolating contact block (164) at the free end of the jumper lead into the fixed secondary isolating contact block (84) on the underside of the fixed portion housing top plate.
- 4.88 Lift the interlock flap (66), open the door (43) and charge and close the breaker, either electrically or manually (see section 5), to apply the earth. The TRIP lever (53) may be padlocked to prevent unauthorised removal of the earth. Electrical tripping is impossible, since the earthing jumper lead does not carry the trip circuit between the fixed and moving portions.

NOTE: An alternative testing jumper assembly which DOES carry the trip circuit is available for use during routine testing of the circuit breakers operation, but must NOT be used for earthing purposes.

- 4.89 To remove the earth, unlock the TRIP lever (53) and trip the breaker. Operate the release lever (104) on the side of the earthing device to release the securing hooks (102). Lower the interlock flap (66) and pivot the black isolating selector (8) to the vertical position. Insert the winding handle (56) into the socket at the end of the isolating screw (62) and wind it anti-clockwise until it rotates freely. Hook your fingers behind the curved handle portion of the interlock flap (66) and pull the moving portion towards you.

#### 4.9 Test Access Device

- 4.91 To give access to the fixed main isolating contacts (44) for testing purposes, a test access device (83) is available.
- 4.92 YOU MUST NOT INSERT ANYTHING OTHER THAN AN APPROVED VOLTAGE INDICATOR INTO THE RECEPTABLE INSULATORS, NOR INTO ANY CHAMBER WHICH NORMALLY HOUSES LIVE METAL PARTS, UNLESS EITHER, THE SWITCHGEAR HAS NOT YET BEEN CONNECTED INTO THE SYSTEM AND COMMISSIONED OR, THE RELEVANT BUSBARS (12, 19) OR CIRCUIT CONNECTION (10) HAVE BEEN MADE DEAD, ISOLATED AND LOCKED OFF AT ALL POSSIBLE POINTS OF SUPPLY AND EFFECTIVELY EARTHED.

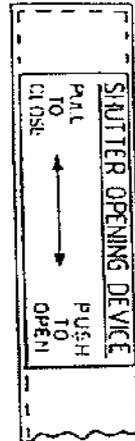

(4-9A) Shutter Opening Device (117)

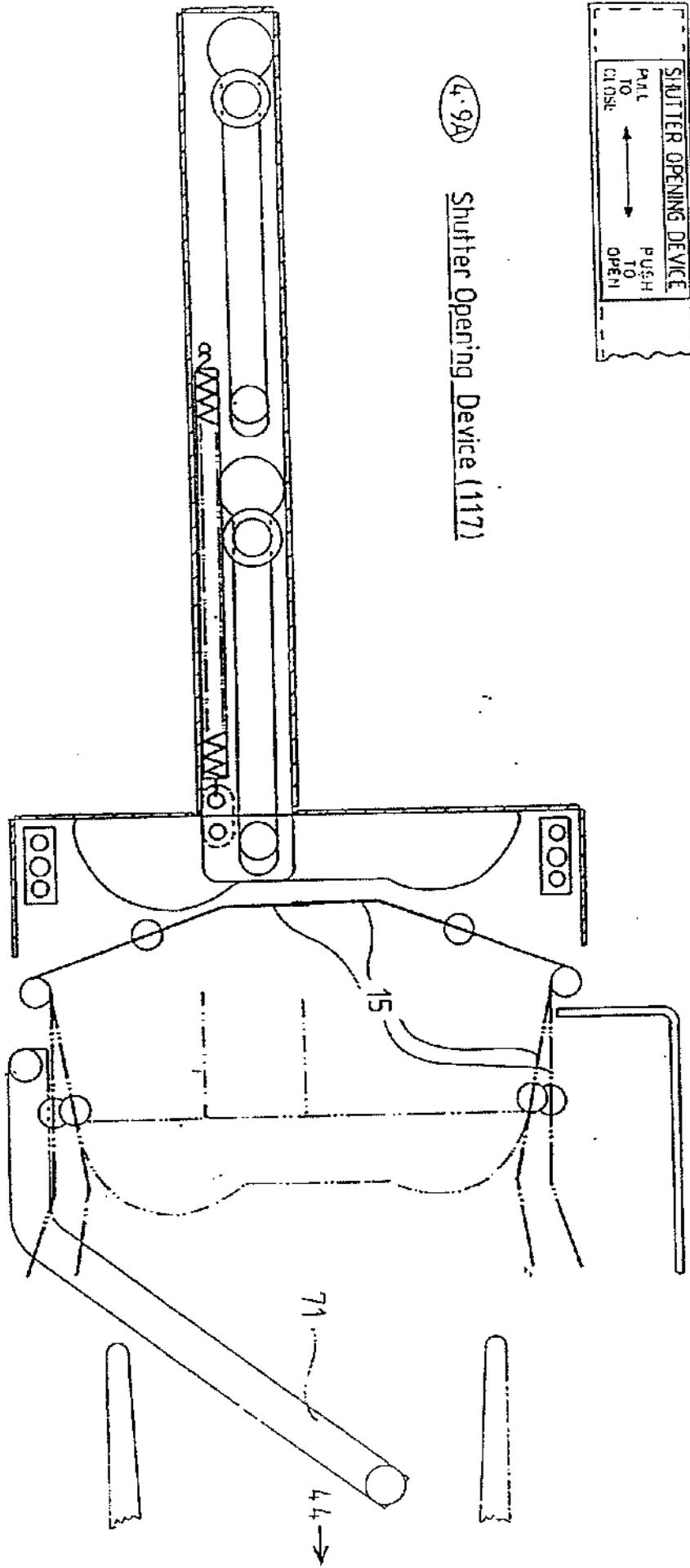

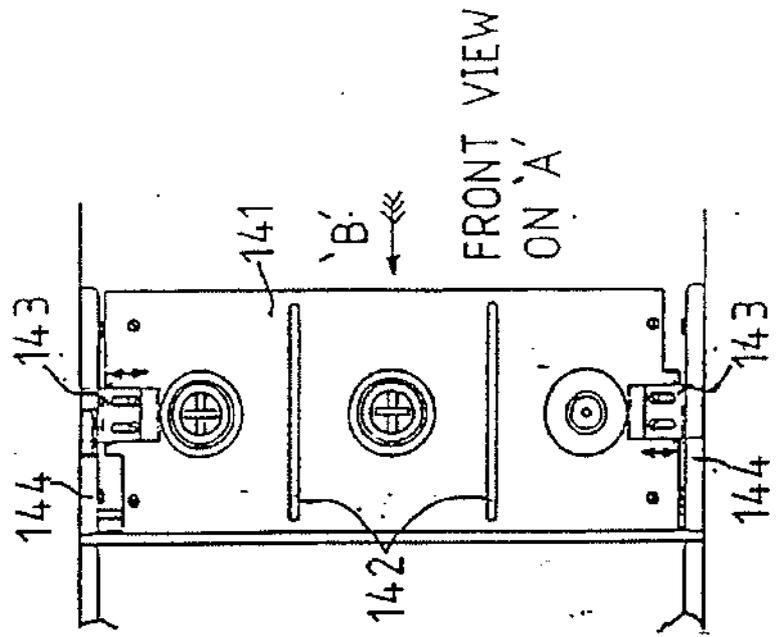
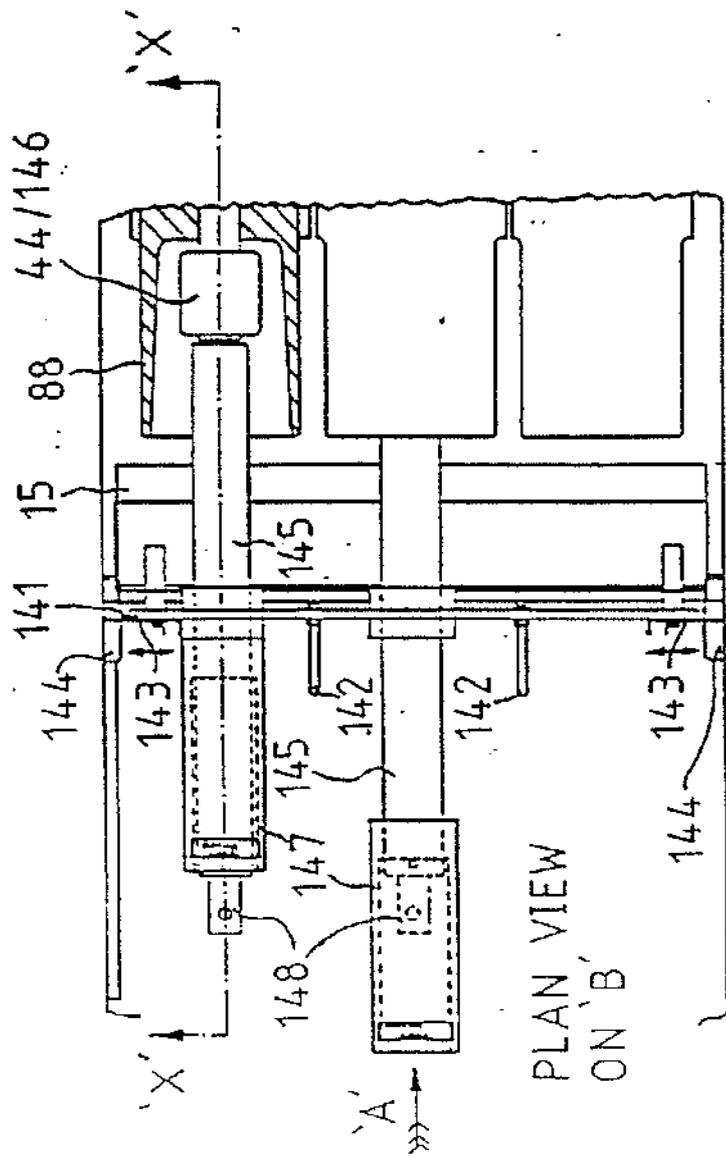
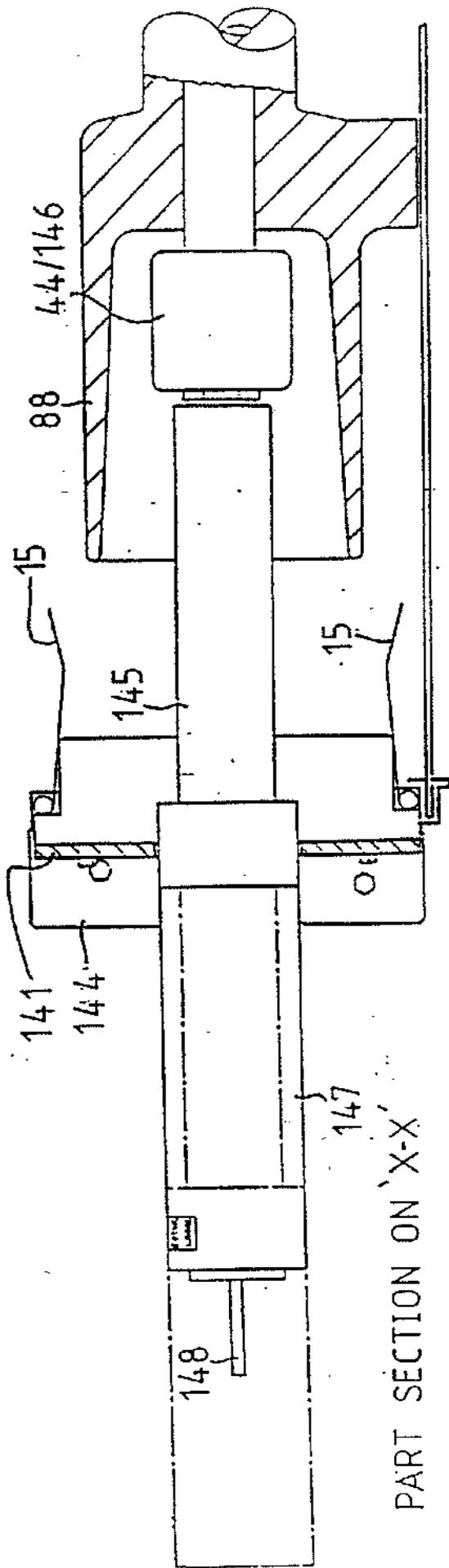

4.9 B TEST ACCESS DEVICE.

- 4.93 To apply the test access device, first open the shutters (15) in front of the contacts concerned by pushing the shutter opening device (117) fully home.
- 4.94 Then, take the test device main plate (141) without its test bushings and, holding it by the two handles (142), place it vertically in the aperture between the shutters and slide the locking bolts (143) outwards so that they lodge behind the shutter side plates (144).
- 4.95 If required (i.e. if the equipment has been previously alive and/or has been commissioned), you can now insert the test bushings of an approved voltage indicating device of relevant rating through the holes in the plate (141).
- 4.96 With the fixed contacts (44) proved dead, you can now insert the test bushings (145) through the holes in the plate (141) and push their contact clusters (146) home onto the fixed contacts.
- 4.97 Each test bushing (145) has a sliding insulated tube (147) at the opposite end to the contact clusters (146). The tube is slid towards the main plate (141) to uncover the test connections (148). For current transformer injection tests, or other tests at relatively low voltage, the tubes can be left in this position with the connections uncovered. However, for high voltage testing the test leads should be fastened to the connections (148) and the tubes (147) should then be slid back as far as possible from the main plate (141) to cover the connections before testing commences.
- 4.98 Removal of the test access device is the reverse of the above.



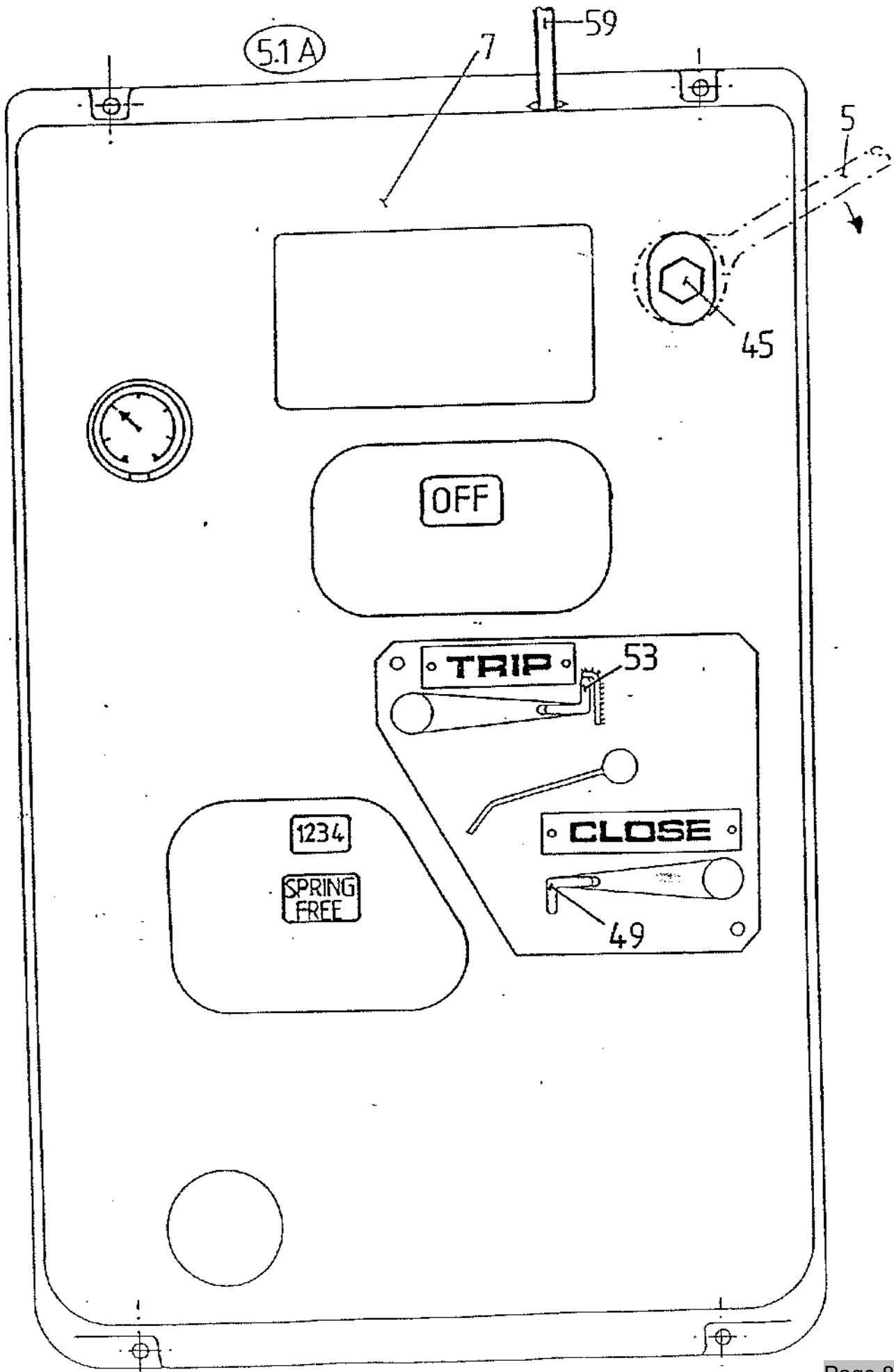

## **5. OPERATION OF SPRING CLOSING MECHANISMS**

### **5.1 To Charge the Closing Springs Manually**

- 5.11 The springs of a unit equipped for hand charging only, or of one equipped with a charging motor which has lost its auxiliary supply or had it disconnected, may equally be charged by one or other of the methods described in the following paragraphs. The springs may be charged with the circuit breaker switched 'OFF' or 'ON' - in the latter case, a second spring closing charge may be stored ready for a rapid reclosure.
- 5.12 The interlocks (see sub-section 1.5) are such that it is only possible to gain access to the spring charging spigot (45) when the moving portion is fully isolated, fully plugged into the service location or in the intermediate 'earthing through portable device' location.
- 5.13 Note the indication 'SPRINGS FREE' and open the moving portion front door (43). Check that the ratchet on the spring charging handle (5) is set to drive clockwise and fit the handle to the charging spigot (45). Move the handle back and forth (or up and down) until the resistance to it stiffens, gives way and then sets solid as the 'SPRINGS CHARGED' condition is reached. Remove the charging handle.

### **5.2 Electrical Charging of the Closing Springs**

- 5.21 For a circuit breaker with spring charging motor, the standard arrangement is such that, with the moving portion plugged in, or isolated but with a jumper connection between the secondary contact blocks (84, 85), the mechanism springs will be automatically charged when the manual AUTO/OFF motor control switch on the instrument panel (1) is set to AUTO.
- 5.22 Immediately the breaker is closed, the springs will be recharged ready for a subsequent reclosure. This will continue until the motor control switch is set to OFF.
- 5.23 If the motor control switch is set to OFF, or the auxiliary supply is lost whilst the springs are being charged, the motor will stop, leaving the closing springs partially charged until power is restored. The breaker cannot be closed in this condition.

### **5.3 To Close the Circuit Breaker**

- 5.31 The closing springs may be discharged to close the circuit breaker in four basic ways:-
- a) by the pressing of the CLOSE lever (49) at the front of the mechanism housing (7);
  - b) by the operation of the electrical TRIP/CLOSE switch on the unit instrument panel (1) so as to energise the close coil (50) within the mechanism housing (7).
  - c) by the operation of a similar TRIP/CLOSE switch at a remote location;
  - d) by the operation of automatic auto-reclose circuitry, where this is provided for a specific installation, to energise the close coil (50).
  - e) NOTE: If the close lever (49) is padlocked to prevent operation, any attempt to close the breaker by local or remote electrical control could result in burning out the close coil (50).

DO NOT ATTEMPT TO press the TRIP lever (53) and CLOSE lever (49) at the same time.

- 5.32 The closing movement of the mechanism automatically charges the mechanism opening springs, and the electrode throw-off springs.
- 5.33 The closing springs may be re-charged immediately the breaker is closed, as discussed in sub-sections 5.1 and 5.2 above.

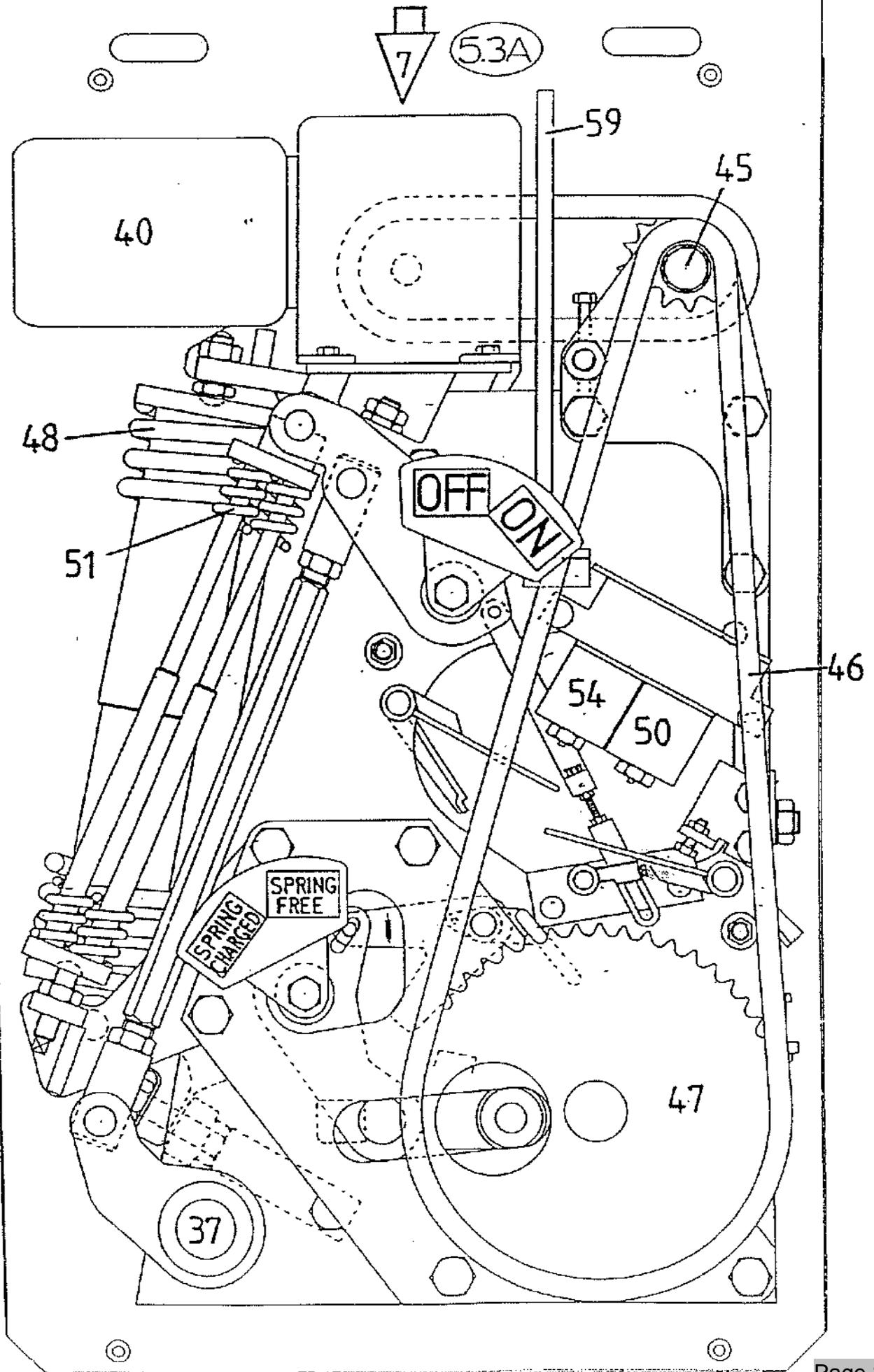

#### **5.4 To Trip the Circuit Breaker**

5.41 The opening springs may be tripped to open the circuit breaker in several ways:

- a) by the pressing of the TRIP lever (53) at the front of the mechanism housing (7);
- b) by the operation of the electrical TRIP/CLOSE switch on the unit instrument panel (1) so as to energise the trip coil (54) within the mechanism housing (7);
- c) by the operation of a similar TRIP/CLOSE switch at a remote location;
- d) by the operation of automatic protective circuitry and/or relays to operate the trip coil (54).

DO NOT attempt to press the TRIP lever (53) and CLOSE lever (49) at the same time.

#### **5.5 Operation of Low-Pressure Lock Out System Single Pressure Switch**

5.51 A pressure switch (86) fitted to the circuit breaker gas module is pre-set at the factory to a pressure below the normal filling pressure of the unit. A reduction in gas pressure to this level causes normally open contacts in the switch to close.

5.52 This illuminates a local L.E.D alarm lamp on the instrument panel (1) and energises a seal-in auxiliary relay circuit.

5.53 The relay has normally open contacts which close to initiate remote alarm operation, and normally closed contacts arranged to open and inhibit electrical tripping and/or closing of the circuit breaker.

5.54 A 'check alarm-reset' push button on the instrument panel (1) has two functions. If it is pressed under normal circumstances it causes the L.E.D lamp to light and the relay to operate as a check that they are functioning. After a genuine alarm, when the low pressure condition has been rectified (or the faulty circuit breaker removed), pressing the same push button resets the relay.

5.55 See also the circuit diagrams for the specific installation. (See section 9.2).

#### **5.6 Operation of Low-Pressure Lock Out System Double Pressure Switch**

5.61 Where a double pressure switch system is fitted, the second switch can be used to operate a warning or alarm.

5.62 The lockout pressures are the same on single and double switches but the alarm pressures on the extra switch are set at approx 0.05 to 0.1 bar higher than lockout. This gives an early warning that lockout will occur.

## **6. INSPECTION, SERVICING AND OVERHAUL REQUIREMENTS**

### **6.1 General Policy**

6.11 This document is to be used as a guide to the maintenance of YSF6 switchgear. It should be read in conjunction with BS.6626:1985, the current British code of practice for the maintenance of electrical switchgear from 650V to 36kV, which sets out recommendations for safe conditions during maintenance work and guidelines for maintenance procedures. (See graph 6.1A).

6.12 Routine maintenance is generally described as:

- a) Inspection and operation check, a general check for cleanliness and correct operation and to detect signs of abnormality.
- b) Servicing, a more detailed inspection during which the equipment is cleaned, lubricated and checked for correct operation.
- c) Examination and overhaul, the investigation and replacement, if necessary, of internal parts considered unsatisfactory following routine inspections.

6.13 YSF6 has been designed to minimise maintenance. Care has been taken to protect the equipment from the ingress of dust and the circuit breaker module is a sealed for life device which needs no contact changes or settings. This eliminates the need to overhaul it. Since the circuit breaker's electrical endurance capability is higher than that required for Performance Level 4 in Appendix C of ESI 41-5:1983, the need for post-fault checks on units employed for normal duties is also eliminated.

6.14 Provided that a YSF6 switchboard is located in a substation which is clean, warm, dry and well-ventilated, maintenance will usually be limited to checking for correct operation and cleanliness, some re-lubrication and the establishment of records. BS.6626 emphasises the benefits of good maintenance records, which should begin at the commissioning stage.

### **6.2 Frequency of Maintenance**

6.21 In view of the foregoing, the following maintenance regime is recommended:

6.22 Inspection and operation checks after a maximum of five years or 500 operations;

6.23 Servicing after a maximum of 10 years or 1000 operations;

6.24 Further alternate inspection and servicing at intervals of five years or 500 operations or, where equipment is operated with extreme frequency, at such intervals as may be decided after consultation with Merlin Gerin.

6.25 If a switchboard has to be made dead for any reason, such as the installation of extension panels, the opportunity may be taken for a general overhaul of the interior of the fixed portions, but this is by no means a routine requirement.

### **6.3 Guarantee**

6.31 Merlin Gerin guarantees any YSF6 equipment during an initial period of 18 months from delivery to site or 12 months from commissioning, whichever is the sooner, provided that the customer does NOT attempt to modify or maintain the equipment within that period.

6.32 Should any circuit breaker moving portion require to be removed from service for any significant period of time during the guarantee period, a complete replacement unit having the same ratings and facilities will be provided. At the end of the guarantee period, maintenance requirements should be in accordance with the recommendations set out above.

Number of operations

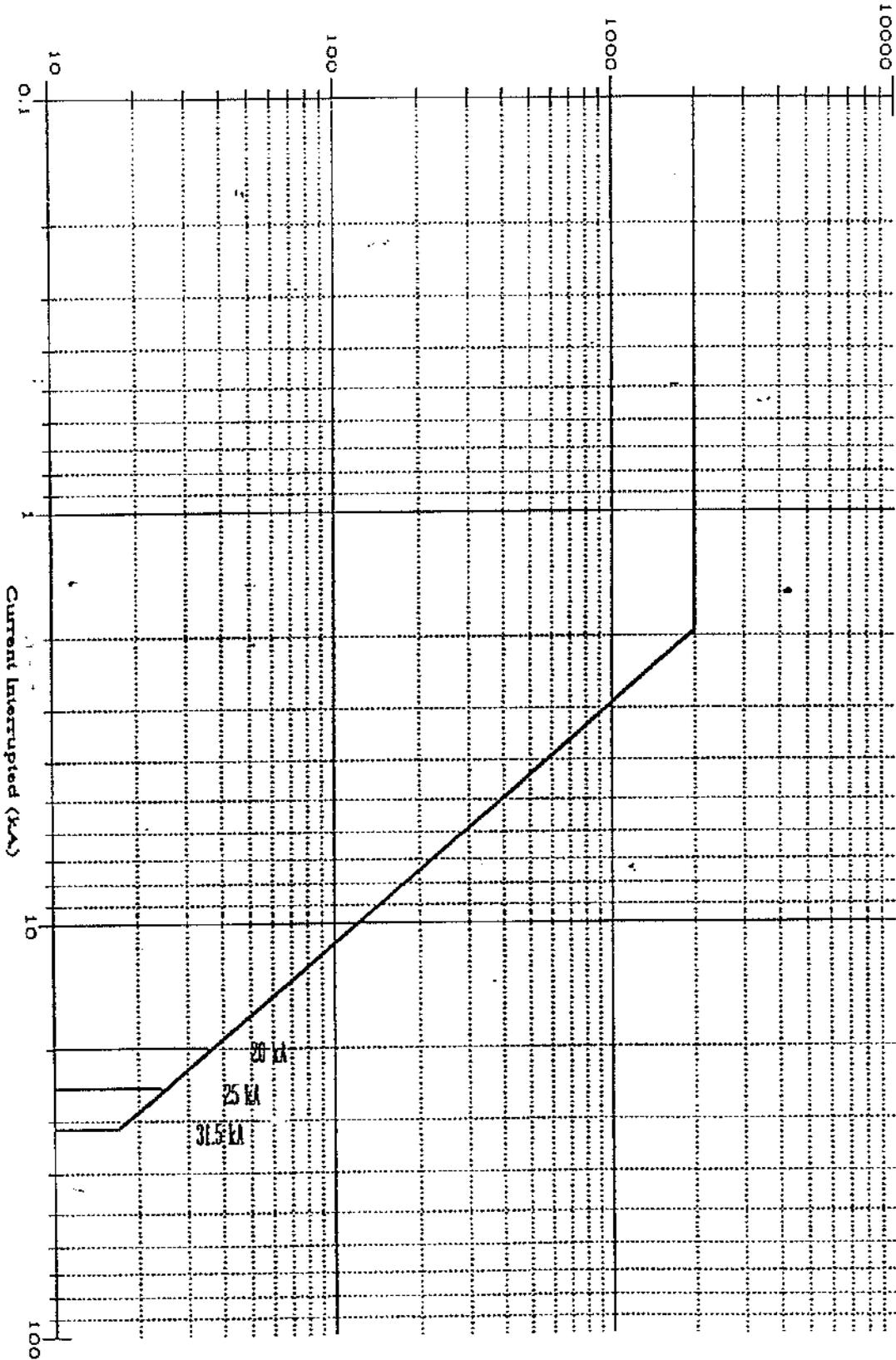
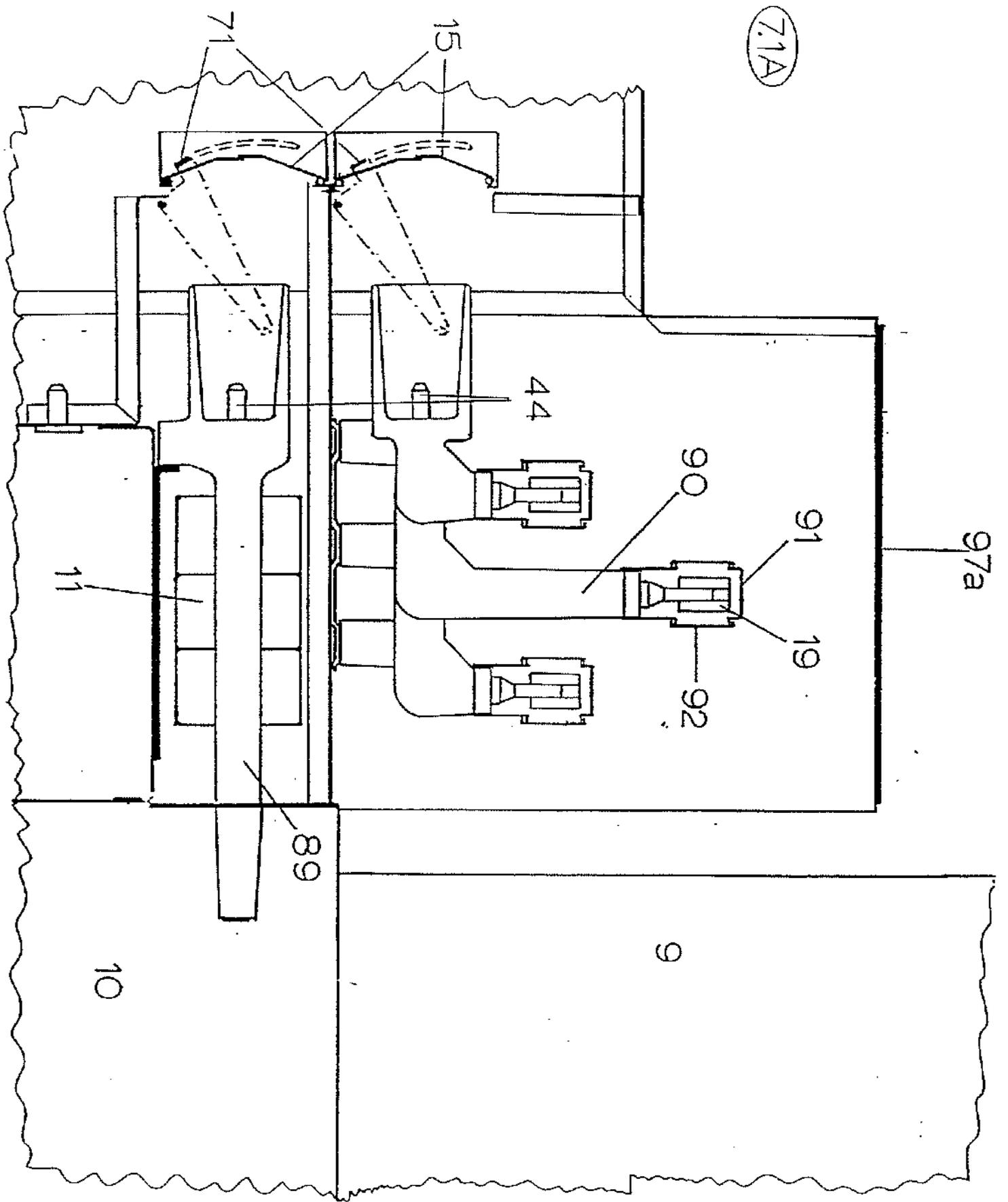

FIGURE 6.1A - PROSPECTIVE INTERRUPTING CAPACITY YSF6 PUFFER CIRCUIT BREAKER

**6.4 Maintenance Agreements**

- 6.41** Customers with only a few YSF6 units in service may feel it is uneconomic for them to train staff, stock spares and purchase equipment for maintenance purposes. They may prefer to negotiate a maintenance contract under which Merlin Gerin will continue to be responsible for the equipment, on a fixed charge or time and materials basis.





## 7. INSPECTION AND MAINTENANCE CHECKS (5 YEARS/500 OPERATIONS)

### 7.1 General Inspection

- 7.11 Inspect the general condition of the switchroom to see that it is clean, dry and adequately heated and ventilated. Listen for any audible discharge, note any unusual smell. Should anything be amiss, investigate the cause and arrange for its correction.
- 7.12 Clean down the outside of the switchgear with cloths having no loose fibres or metallic threads. Do not use synthetic cloths in conjunction with cleaning solvents.
- 7.13 Check for any damaged paintwork. Damaged areas should be cleaned and re-coated as follows:
- 7.14 Rub down area around the damage with medium glass paper. Clean the damaged area with emery paper, ensuring that the surface is clean and free of corrosion. Apply a 35-40 micron thick coat of zinc-rich epoxy primer. A two-pack system such as 'International Paints' Interzinc EPA 072 and EPA 073 is recommended.
- 7.15 Leave to cure for 24 hours then apply two, 35-40 micron thick coats (i.e. 70-80 microns in all) of two pack polyurethane such as Interphane PFR 764.
- 7.16 The standard colours employed are:
- |  |               |
|--|---------------|
| Signal red (busbar shutters)           | 537 (BS.381C) |
| Lemon yellow (circuit shutters)        | 355 (BS.381C) |
| Dark admiralty grey (overall cladding) | 632 (BS.381C) |

### 7.2 Operational Check

- 7.21 Trip and isolate each moving portion to be inspected in turn and charge, close and trip it, both manually and electrically (see section 4 of this manual).
- 7.22 A testing jumper assembly which carries the charging, tripping and closing circuits between the secondary isolating contacts of the fixed and moving portions is available to facilitate the operational testing of isolated moving portions.

### 7.3 Number of Operations

- 7.31 Check and record the number of operations shown on the operations counter.

### 7.4 Gas Pressure

- 7.41 If the unit is equipped with an integral pressure gauge (154), check and record the gas pressure as indicated.
- 7.42 The data label on the moving portion lower front panel shows gas pressure recommendations in graphical form. The filling pressure is dependent upon the ambient temperature.

$$\text{Bar Gauge Pressure} = \frac{\text{Pressure in kilopascals}}{100}$$

- 7.43 If the unit is NOT equipped with an integral pressure gauge, it is NOT recommended that the pressure be checked routinely by means of a hand-held pressure gauge, as this in itself leads to a slight loss of gas pressure.
- 7.44 Tests and a decade of service experience show typical leakage rates to be below 0.05% per annum, by volume. All units are fitted with a pressure switch and relay which operate if the internal pressure drops below a pre-set level. The relay can be arranged to operate local or remote alarms or indicators, to disconnect the trip and close circuits or to trip the breaker immediately, according to customers' requirements.

## **7.5 Isolating Contacts**

- 7.51 Remove the isolating contact clusters (41) from the moving portions by unfastening their internal securing screws.
- 7.52 Using a lint-free rag, clean any old grease or loose dirt from the ends of the moulding conductor stems. The radius at the end of each stem should be reasonably smooth and free from severe dents or irregularities.
- 7.53 Apply a thin, even layer of a recognised contact grease, such as Electrolube type 2G, over the radius at the end of the stem. Insert a small amount of the grease into the hole in the end of the stem.
- 7.54 Clean any old grease or loose dirt from the contact cluster assemblies with a lint-free rag and inspect the contact fingers for damage. If any cluster has more than two or three significant pit marks on the contact areas at either end, replace the entire cluster.
- 7.55 Apply a thin, even layer of the contact grease over the entire contact areas which have been cleaned.
- 7.56 Re-fit the clusters to their supporting stems.

## **7.6 Moving Portion Insulation Cleaning**

- 7.61 Examine the external insulator surfaces on the moving portion and clean them if necessary, using lint-free, non-metallic, non-synthetic cloths and 1.1.1 trichloroethane, which can be obtained in the UK as:
- 7.62 "ICI Genklene", from  
Ellis & Everard  
Dudley Hill Chemical Works  
Holme Lane  
Bradford 4  
West Yorkshire
- 7.63 "Electrolube Ultraclene V", from  
Automation Facilities Ltd  
Blakes Road  
Wargrave  
Berkshire RG10 8AW
- 7.64 Inspect the insulators for signs of damage. Minor surface scratches are unimportant, but if severe damage is found, remove the unit from service and inform Merlin Gerin.

## **7.7 Insulation Resistance Check**

- 7.71 Measure and record the surface resistivity of the bushing stems supporting the contact clusters (41). Provided that the insulation is dry and has been cleaned effectively, a surface resistivity of not less than 40,000 megohms will be obtained.

**7.8 Visual Inspection of Fixed Portion**

- 7.81 NOTE THAT YOU MUST NOT WORK ON THE SAFETY SHUTTERS (15) OF A FIXED PORTION, NOR LEAN ON THEM, NOR OPERATE THEM DIRECTLY, NOR INSERT ANYTHING INTO THE RECEPTACLE INSULATORS (88) BEHIND THEM, NOR INTO ANY CHAMBER WHICH NORMALLY HOUSES LIVE METAL PARTS, NOR REMOVE ANY PART OF THE PROTECTIVE METAL CLADDING, UNLESS THE SWITCHBOARD BUSBARS (12, 19) AND ASSOCIATED CIRCUIT CONNECTION (10) OF THAT FIXED PORTION HAVE BEEN MADE DEAD, ISOLATED AND LOCKED OFF AT ALL POSSIBLE POINTS OF SUPPLY AND EFFECTIVELY EARTHED.
- 7.82 With the moving portion withdrawn, BUT THE FIXED PORTION STILL ALIVE, check the remote operation of the fixed portion safety shutters (15) by pushing fully home the shutter opening devices (117) on the fixed portion left hand side wall, until the shutters are propped open.
- 7.83 Look into the receptacle insulators (88) to see that the male, fixed main isolating contacts (44) are undamaged and there is no foreign body or excessive dust in the receptacles.
- 7.84 Lubricate the accessible parts of the shutter opening devices OUTSIDE the shutter apertures with a light machine oil.
- 7.85 Reclose the shutters by pulling back the opening devices. Lubricate the shutter hinges with a light machine oil.

## 8. SERVICING (10 YEARS/1000 OPERATIONS)

### 8.1 Inspection and Operation Checks

8.11 Repeat all the inspection and operation checks detailed in Section 7 of this manual, as well as the following additional service operations.

### 8.2 Mechanism

8.21 With the moving portion withdrawn from the fixed portion, the springs free and the moving portion front panel door (43) closed, lower the interlock flap (66). Pivot the isolating selector (8) to give access to the grub screw which secures it to its shaft (63) and remove the screw. Pull the selector off its shaft. Raise the interlock flap (66) and open the front panel door (43). Remove the five screws which secure the front panel (42) to the carriage (diagram 8.2A). Note that two of the screws are integral with the door opening stay. Remove the front panel and front panel door.

8.22 Remove the following components and assemblies in turn: The red height pointer (165) fitted to the left hand moving portion side sheet (two screws and nuts); The trip/close controls plate (166) (two screws); The two screws (167) which secure the mechanism cover to the conduit elbow bracket; Where a front-mounted gas filler (153) is fitted, break the lockwire and remove the filler cap retaining chain and lockwire anchor pillar (168); Auxiliary drive tube (169); Mechanism cover fixing nuts (170).

(See diagrams 8.2B and 8.2C).

8.23 Remove the mechanism cover (171) by pulling forwards and upwards over the auxiliary drive shaft protruding from its top. The exposed mechanism should need no more than a wipe with a lightly oiled rag or brushing with a 50-75mm stiff bristle brush.

8.24 Diagram 8.2D shows the complete mechanism and 8.2E shows a section between the main plates. The rotating, semi-rotating and sliding components requiring lubrication are indicated by: (G) for grease, (O) for oil and (W) for Waxoyl if available.

8.25 Since not all of the components between the main plates are accessible, it is permissible to apply an oil spray or oil fog to the whole of this area through the apertures in the plates. The oil may be diluted with 5% Genklene or equivalent fluid to reduce its viscosity. Cover the floor beneath the mechanism with paper or cloths to catch the excess and leave the mechanism to drain for some time before re-fitting the cover.

8.26 Replace all components, including the lockwire, in the reverse order.

8.27 Recommended lubricants are:

Grease:	Shell Livona 3 or Castrol Spheerol AP2;
Oil:	Shell Vitrea 68 or Castrol Magna 68;
Waxoyl:	From car accessory stores or Finnegans Speciality Paints Ltd Eltringham Works Prudhoe Northumberland.

### 8.3 Earth Connection

8.31 Check all earth connections on the fixed and moving portions for tightness of joints.

### 8.4 Auxiliary Switches & Interlocks

8.41 So far as is practicable, check all auxiliary switches, interlocks and padlocking points on both fixed and moving portions for correct operation, in accordance with sub-section 1.5 of this manual.

### 8.5 Isolating & Elevating Mechanisms

8.51 Clean and re-lubricate with a general purpose grease the isolating and elevating screw mechanisms on the moving portion.

### 8.6 VT & Secondary Circuitry

8.61 If a voltage transformer (VT) (9) is fitted, isolate the VT and check the high voltage fuses.

8.62 Clean and re-lubricate with a general purpose grease the elevating screw mechanism on the VT.

8.63 Check the low voltage fuses in the relay and instrument compartment.

8.64 Whilst the fuses are out, clean and examine the relays and protective equipment in accordance with the makers' instructions. Note that current transformer terminations must not be open-circuited, since this can give rise to dangerously high voltages.

8.65 As far as is practicable, check all secondary wiring terminations.

8.66 Replace all fuses and rack the VT back in.

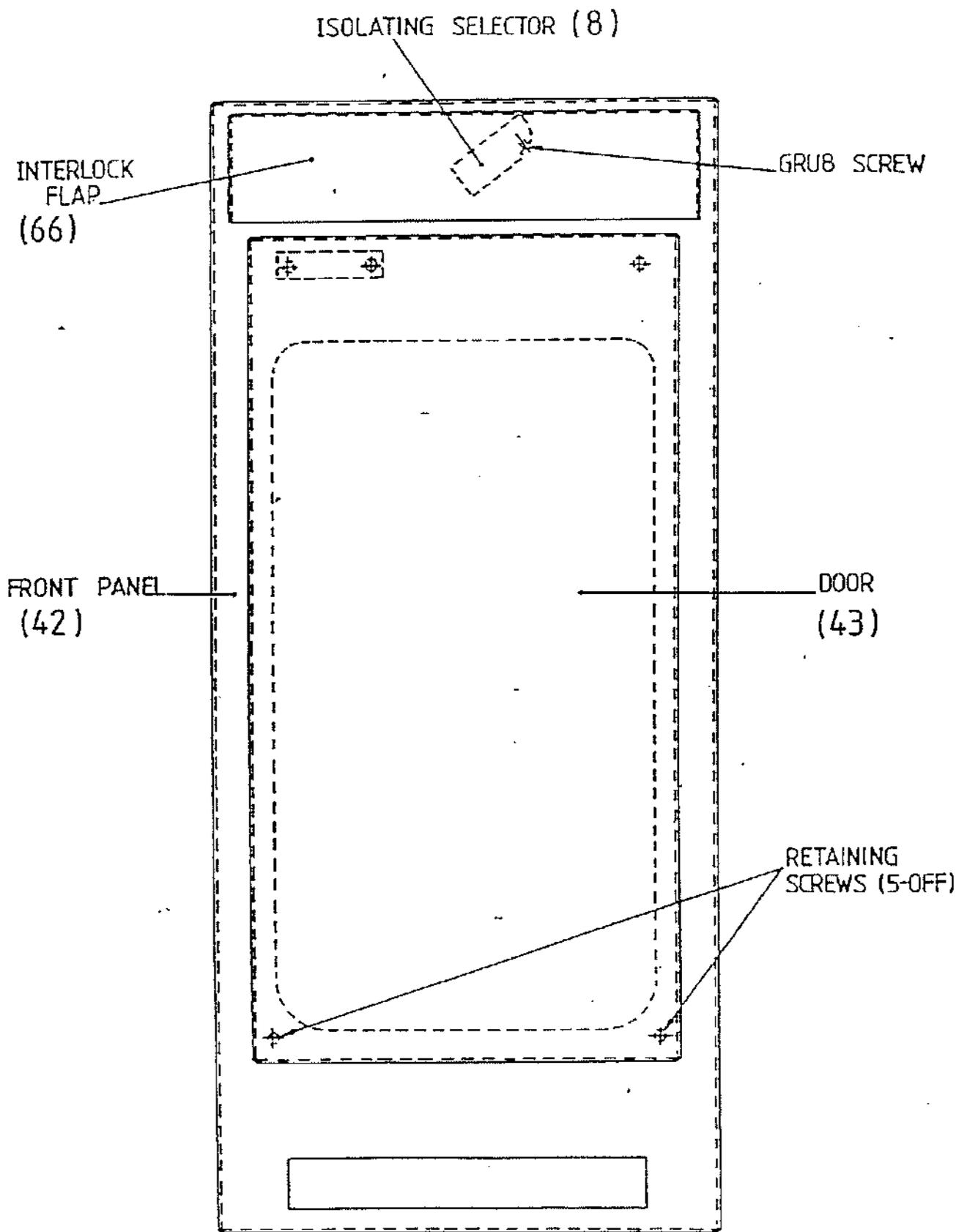

DIAGRAM (8-2A)

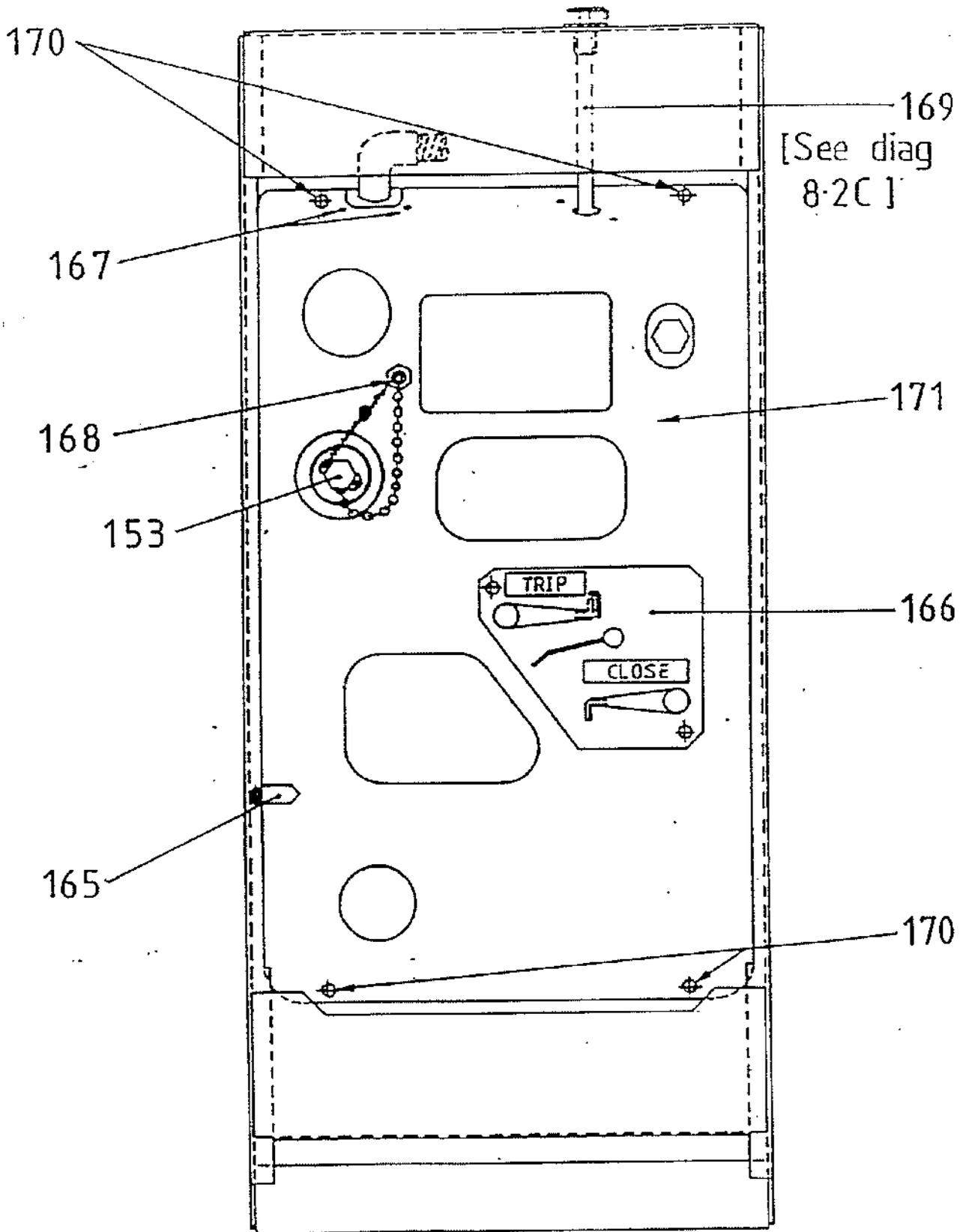

DIAGRAM (8-2 B)

NOTE-CIRCUIT BREAKER SHOWN IN APPROXIMATE MID POSITION.

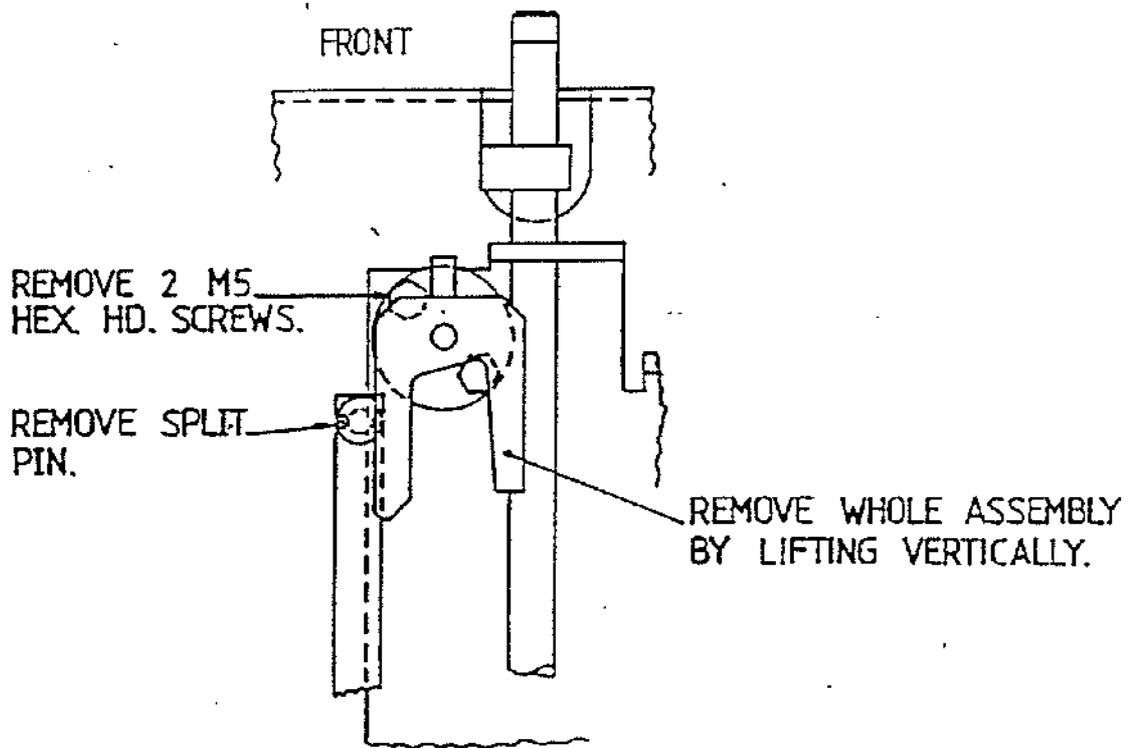

DIAGRAM (8-2C)  
(PART PLAN VIEW OF CARRIAGE TOP SHEET)



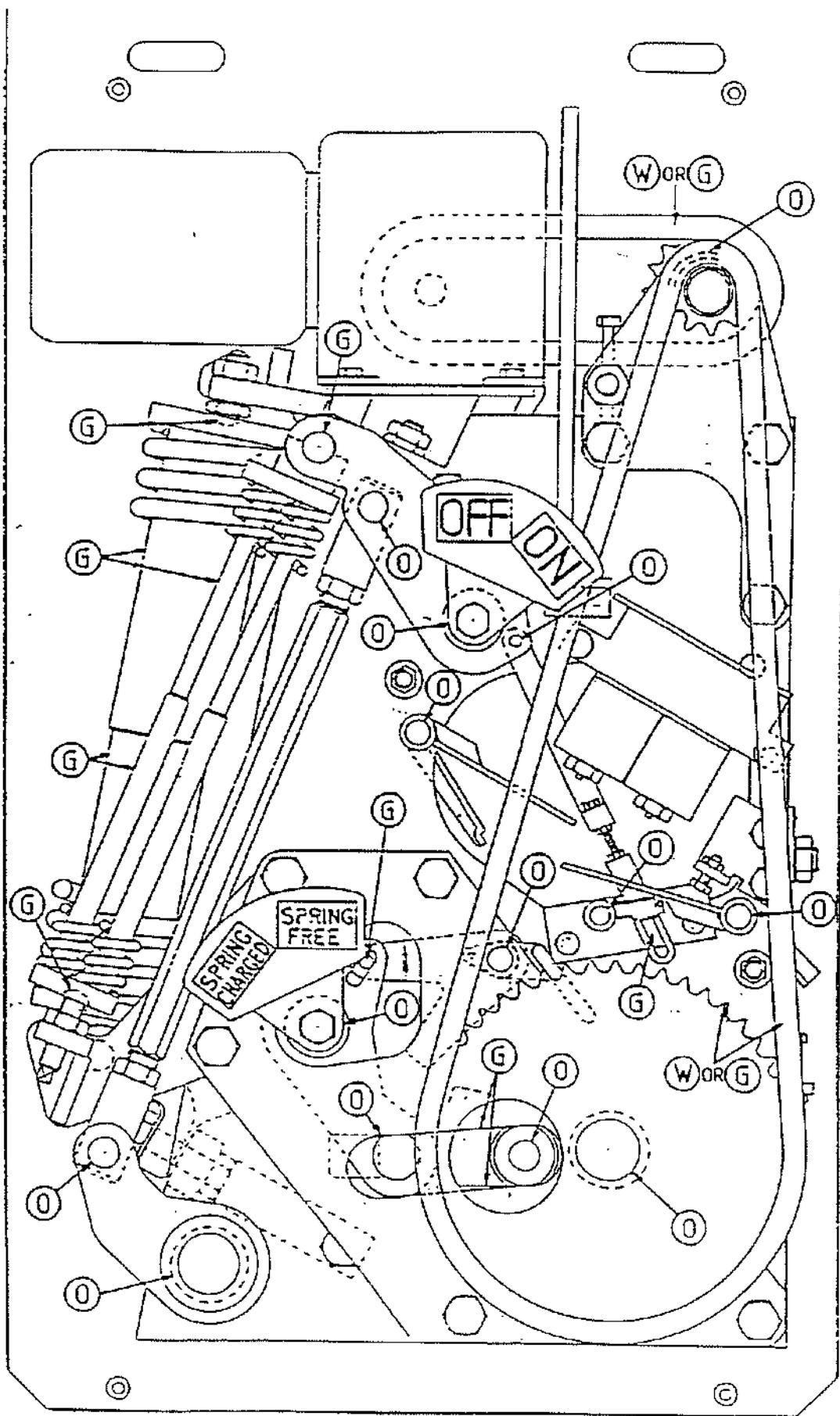

DIAGRAM. 8-2 D

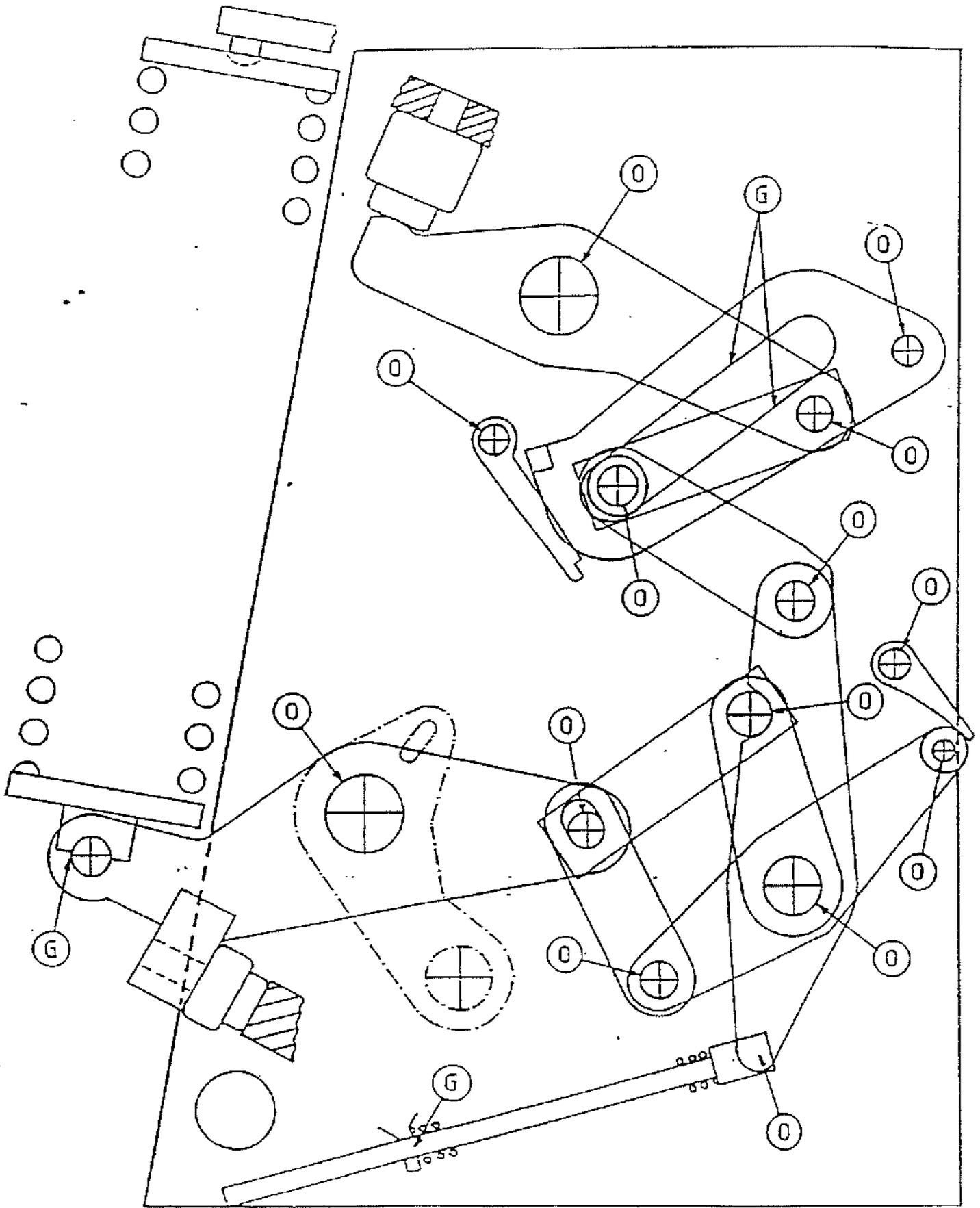

DIAGRAM 8-2E

## 9. ADDITIONAL MAINTENANCE OPERATIONS IN EXCEPTIONAL CASES

### 9.1 Gas Pressure Testing & Filling

- 9.11 See the note in sub-section 7.4 of this manual concerning the inadvisability of checking the pressure routinely by means of a hand-held pressure gauge where an integral gauge is not fitted, as this leads to a gradual loss of gas pressure. However, it is possible to perform such a check at long intervals, or after a low pressure alarm. Two types of gas filler, rear-mounted and front-mounted, are in use on YSF6 units. Both are dealt with in this section. Both can be used for testing the internal gas pressure and for topping up the gas.
- 9.12 To test the pressure via a rear-mounted filler, isolate the moving portion from the switchboard and break and remove the filling point lockwire and seal. Remove the plug from the filler, leaving the locking ring in position. Fit the hand-held pressure gauge, using PTFE sealing tape. Lift out the locking ring and open the valve. Read off the pressure as quickly as possible and re-close the valve. Re-fit the locking ring. Remove the pressure gauge and re-fit the plug, using PTFE sealing tape. Lockwire the locking ring, valve handle and plug together, sealing if required. Test for leaks using a conventional SF6 sniffer device with a sensitivity of at least 10 parts per million.
- 9.13 To top up the gas via a rear-mounted filler, the procedure is the same as for testing the pressure except that the filling pipe from the SF6 cylinder is fitted in place of the hand-held pressure gauge.
- 9.14 Where a front-mounted filler is fitted, it is possible to test the pressure with the moving portion plugged into the fixed portion, but this is not recommended in the interests of safety. With the moving portion isolated from the switchboard, open the front panel door and break and remove the lockwire and seal. Unscrew and remove the brass filler plug cover cap, ensuring that the 'O' ring is retained in its groove or removed to a clean, safe place. Snap the quick-release coupling socket/ pressure gauge assembly. (See paragraph 9.16 below) onto the filler plug. Read off the pressure, then remove the coupling/gauge assembly. Re-grease the 'O' ring with petroleum jelly and replace it so that it is correctly seated in the groove in the boss. Screw on the brass cover cap. Lockwire the cap to the anchor pillar and seal if required.
- 9.15 To top up the gas via a front-mounted filler, the procedure is the same as for testing the pressure, except that the coupling socket/pressure gauge assembly is replaced by a coupling socket/filler pipe assembly.
- 9.16 Quick release coupling sockets and coupling socket/pressure gauge assemblies for the front mounted filler are available from Merlin Gerin, or from other suppliers. Either of the following types should be used:-

Dyna-Quip (IMI Norgren Enots) Type DHS440BP  
Hanson Type B2K16-BS

Both are brass, with a ¼ inch female parallel pipe thread.

### 9.2 Action in the Event of Low Gas Pressure

- 9.21 The automatic lockout system will prevent automatic or remote operation of the circuit breaker once the low pressure relay has operated, unless the customer has specified some other mode of operation.
- 9.22 Disconnect the load or supply at the remote end of the affected feeder or transformer circuit and then trip the breaker manually on charging current only.
- 9.23 Check the gas pressure in the breaker by means of the integral pressure gauge if fitted, or by means of a hand-held gauge (see sub-section 9.1 above).
- 9.24 If the pressure is not low, check the operation of the pressure switch (86) and its associated relay and circuitry.

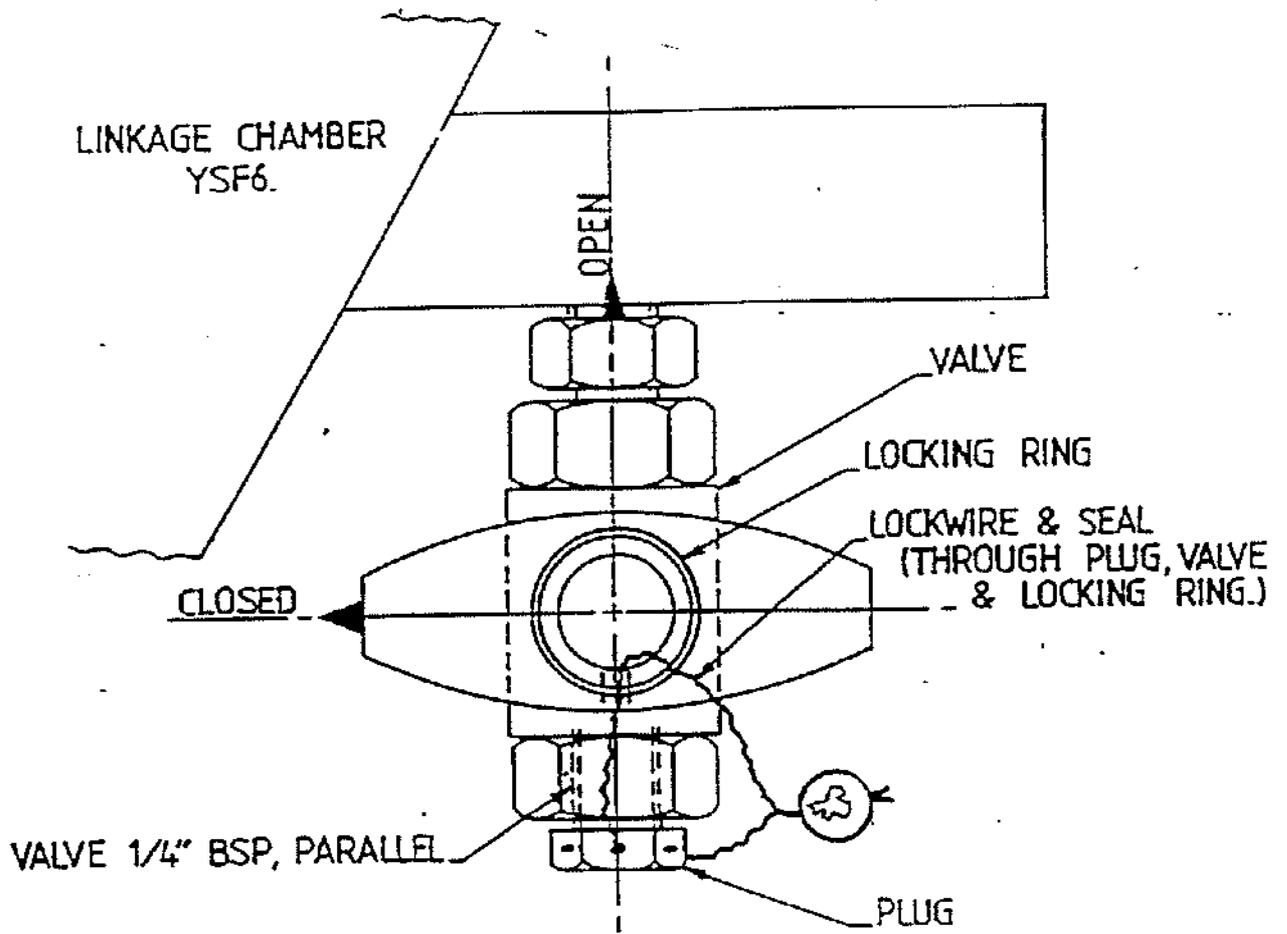

NOTE-VALVE HANDLE SHOWN CLOSED.

DIAGRAM

9-1A

9.25 If no fault is found, withdraw the unit from service and contact Merlin Gerin for further assistance.

### 9.3 Leakage of SF6 By-Products

9.31 In the extremely unlikely event of a serious leakage of SF6 gas which has been subjected to arcing in service, such as would occur if the gas module envelope were severely damaged, the presence of any potentially toxic by-products would be obvious at concentrations far below danger level because of their nauseous smell (like rotten eggs).

9.32 The area should be energetically ventilated to clear the airborne products (and the smell) before the switchroom is entered.

9.33 Suitable gloves and a mask fitted with an approved filter, should be worn during cleaning-up operations. The gloves should then be thoroughly washed and rinsed and the mask's filter should be carefully disposed of.

9.34 The above precautions are unnecessary for the purposes of checking the pressure and topping up under normal conditions. The internal molecular sieve absorbs normal by-products. Normal personal hygiene must be observed.

### 9.4 Fixed Portion General Overhaul During Switchboard Outage

9.41 If a switchboard has to be made dead for any reason, such as the installation of extension panels, the opportunity may be taken for a general overhaul of the interior of the fixed portions, but this is by no means a routine requirement. It involves the inspection, cleaning and maintenance of equipment within the busbar chambers, current transformer chamber, voltage transformer tank, cable box and fixed main contact system, in addition to the work covered in sections 7 and 8 of this manual.

9.42 UNTIL THE SWITCHBOARD BUSBARS (12, 19) AND ASSOCIATED CIRCUIT CONNECTION (10) OF ANY FIXED PORTION HAVE BEEN MADE DEAD, ISOLATED AND LOCKED OFF AT ALL POSSIBLE POINTS OF SUPPLY AND EFFECTIVELY EARTHED, YOU MUST NOT INSERT ANYTHING INTO THE RECEPTACLE INSULATORS NOR INTO ANY CHAMBER WHICH NORMALLY HOUSES LIVE METAL PARTS, NOR MUST YOU REMOVE ANY PART OF THE PROTECTIVE METAL CLADDING.

9.43 Padlock each shutter locking lug (71) in turn and note that in each case it is now impossible to push open the shutter (15). Remove the padlocks, lower the lugs and wedge the shutters open in turn by means of the shutter opening devices (117) on the fixed portion left hand sidewall.

9.44 MAKE SURE THAT ALL FIXED CONTACTS (44) ARE DEAD, by means of an approved testing device, then remove the busbar chamber top and/or rear and/or front plates (97, 98). Check that the busbar (90) and circuit (89) resin mouldings are secure and that the busbars (12, 19) are held firmly in position. Check that the busbar tee-off shrouds (91) are securely in position. Clean the busbars and mouldings.

9.45 Remove any solidified grease from the male fixed isolating contacts (44) using a lint-free cloth. Apply a thin, uniform film of a recognised contact grease (e.g. Electrolube type G2) to the contact surfaces, but keep it off the resin surfaces. Clean all accessible insulator surfaces with 1.1.1 trichloroethane (see sub-section 7.6 of this manual) and a lint-free, non-metallic, non-synthetic cloth.

9.46 Replace the busbar chamber top and/or rear and/or front plates (97.98).

9.47 Lubricant the shutter (15) hinges and locking bar (71) pivots. Allow the shutters to close by pulling back the shutter opening devices (117).

- 9.48 Where a voltage transformer (VT) (9) is fitted, remove its cover and note the general condition of the interior. Check the condition of contacts. Replace the cover.
- 9.49 AFTER ENSURING THAT THE INCOMING OR OUTGOING CIRCUIT IS DEAD, remove the cable box cover plate (99) and check the terminations. Clean the cable box and insulation and re-close box.

## 11. KEY TO ILLUSTRATIONS

1. Relay and instrument accommodation
2. Circuit breaker lowered to 'transfer earthing' position (where applicable)
3. Circuit breaker in 'service' or 'upper busbar' position (as applicable)
4. Cast resin 'puffer' circuit breaker moulding incorporating 3 x single phase chambers.
5. Spring charging handle
6. Moving portion carriage
7. Mechanism housing
8. Hold-in interlock or isolating selector
9. Cast resin voltage transformer
10. Air insulated cable box
11. Current transformers
12. Lower busbars
13. Earth connection
14. Elevating screw handle location
15. Padlockable safety shutters: a) circuit, b) lower busbars, c) upper busbars
16. Transfer earth star point contacts
17. Pilot cable box
18. Circuit breaker lowered to 'lower busbar' position (where applicable).
19. Upper busbars
20. Spring loaded flap valves
21. Section of cast resin enclosure (see 4) around one single phase chamber
22. Upper isolating contact bushing conductor ('puffer' units)
23. Sprung fixed main contact fingers
24. Insulating nozzle
25. a) Compressor piston, b) moving main contact face
26. Piston ring
27. Sprung upper arcing electrode
28. Lower arcing electrode
29. Main conductor rod
30. Lower isolating contact bushing conductor
31. Partition/moving contact connections support frame
32. Insulated sliding bearing for (29)
33. Insulated drive link
34. Gas seal between (21) and (35)
35. Metal drive linkage housing (common to all phases)
36. Drive linkage
37. Input drive shaft from mechanism
38. Filter pack to absorb products of arcing
39. Flexible laminated copper electrode connections a) upper, b) lower
40. Spring charging motor
41. Moving main isolating contacts: a) upper, b) lower
42. Moving portion front panel
43. Moving portion front panel door
44. Fixed main isolating contacts; a) feeder, b) lower busbars, c) upper busbars
45. Spring charging spigot for (5)
46. Mechanism drive chain
47. Ratchet chain wheel
48. Closing spring
49. 'CLOSE' lever on mechanism
50. Close coil on mechanism
51. Opening springs
52. Upper electrode springs
53. 'TRIP' lever on mechanism
54. Trip coil on mechanism
55. Portable earthing devices a) yellow for circuit, b) red for busbars
56. a) Isolating long winding handle, b) elevating short winding handle
57. Auxiliary switch assembly

58. Auxiliary switch drive forks a) at front of moving portion, b) towards rear of moving portion.
59. Auxiliary switch telescopic drive rod
60. Moving portion top plate
61. Interlock lug on (58)
62. Horizontal isolating screw
63. Isolating selector rod operated by (8)
64. Hold-in block on (63)
65. Hold-in bracket assembly engaged by (64)
66. Interlock flap on (42)
67. Interlock cam on (63)
68. Switch operated by (67)
69. Vertical location interlock rubbing plates
70. Interlock lugs engaged by (69)
71. Shutter locking lugs a) feeder, c) upper busbars
72. Screwed block engaged by (62)
73. GRP moulding on (55)
74. Earthing star point contacts on (55)
75. Contact clusters on (55)
76. Locking handle on (55)
77. Horizontal operating shaft on (55)
78. Securing forks on (55)
79. Earthing bars on moving portion engaged by (78)
80. Claw cams on (55)
81. Bosses on moving portion engaged by (80)
82. Spouts formed by (73)
83. Test access device
84. Fixed secondary contact blocks
85. Moving secondary contact blocks
86. Low pressure switch
87. Micro switch to prevent remote operation in Transfer Earth position
88. Receptacle insulators round (44), a) feeder circuit, b) lower busbars, c) upper busbars
89. bar primary bushings for (11)
90. Busbar support moulding, b) lower busbars, c) upper busbars
91. Busbar tee off shrouds
92. Covers for (91)
93. Foundation channels
94. Foundation channel spring nuts
95. Chases for (93)
96. Tie bar jig for (93)
97. Upper busbar chamber access plates a) top, b) rear
98. Lower busbar chamber access plates a) front, b) rear
99. Cable box cover
100. Nut/screw/washer sets to fasten housings together
101. Apron in front of fixed portion
102. Earthing device securing hooks to engage (103)
103. Earthing device securing bosses on fixed portion a) lower, b) upper
104. Earthing device release lever
105. Busbar tee off connection
106. Busbar fishplate packer a) 630/1250A, b) 1250/1250A, c) 1250/2300A, d) 630/2300A
107. Busbar end panel packet a) 1250A busbar, b) 2300A busbar
108. Clamping jig for filling (91, 92)
109. Filling nozzle for busbar shroud compound
110. 'Dyscon' cable termination adaptor
111. Plug for (110)
112. Cable lug
113. Heat shrink sleeve for cable core
114. Earthing device earth wipe contacts
115. Busbar offset packet a) 1250A busbar, b) 2500A busbar
116. Interlock lug on (63) engaged by (61)



117. Integral shutter opening device
118. Interlock pads on non-reversible (55) (where fitted)
119. Shrouded earthing contact stems on (55)
120. Shutter operating rods on (55)
121. Removal instruction label on (104)
122. Earthing location identifying label (various) on (104)
123. Height interlock block
124. Identification label (various) on (55)
125. Rating label (various) on (55)
126. Serial number label on (55)
127. 'Dyscon' extension adaptor for additional cable core
128. U-section instrument panel fascia plate (550mm centres)
129. Inter-unit fastenings to secure lower fascia plate (550mm centres)
130. Inter-unit fastenings with housing spacers (550mm centres)
131. Housing spacers (550mm centres)
132. Packing plates for (131) (550mm centres) (integral with fixed portion side sheets)
133. Inter-panel conduit (550mm centres)
134. U-section lower fascia plate (550mm centres)
135. Two-part busbar chamber spacer (550mm centres)
136. Gaskets
137. Busbar end cover (in two halves)
138. Securing clamps for (137)
139. Strap securing two halves of (137)
140. Gasket between (137) and (139)
141. Main plate of test access device (83)
142. Handles on (141)
143. Locking bolts on (141)
144. Shutter side plates engage by (143)
145. Test bushings for (83)
146. Contact clusters on (145)
147. Sliding insulated tube on (145)
148. Test connections on (145)
152. Inter bus chamber channel on units above 15kV
153. SF6 gas filling and testing point
154. Optional integral pressure gauge
155. Earthing jumper lead assembly
156. Secondary isolating contact block on underside of (157)
157. Plate of (155)
158. Racking-in device associated with (155)
159. Tapped hold in (158)
160. Plate of (158)
161. Shoulder at end of screw thread on (62)
162. Interlock block on (158)
163. Vertical front edge of fixed portion housing top plate
164. Secondary isolating contact block on free end of (155)
165. Red height pointer on moving portion
166. Trip/close control plate
167. Puffer breaker mechanism cover bracket screws
168. Front gas filler lockwise anchor pillar
169. Auxiliary drive tube
170. Puffer breaker mechanism fixing screws
171. Puffer breaker mechanism cover fixing screws.