

# USE, INSTALLATION AND MAINTENANCE INSTRUCTIONS FOR BUILT-IN HOT PLATES

Dear Customer

Thank you for purchasing a Blanco Cooktop.

Before we continue telling you about this cooktop, we cordially invite you to become part of the Blanco family by subscribing to ongoing information and invitations. Please visit our website where you can subscribe and request such things as invitations to future cooking classes and gourmet recipes. Go to [www.meaappliances.com.au](http://www.meaappliances.com.au) and fill in the subscription details.

You will find that the clean lines and modern look of your Blanco Cooktop blends perfectly with your kitchen décor. It is easy to use and performs to a high standard.

Blanco also makes a range of products that will enhance your kitchen such as ovens, rangehoods, dishwashers, microwaves, sinks and taps.

There are models to complement your new Blanco Cooktop.

Of course we make every effort to ensure that our products meet all your requirements, and our Customer Relations department is at your disposal, to answer your questions and to listen to all your suggestions (see back cover of manual).

Please complete the warranty section of this manual and keep your receipt as proof of purchase. Retain all documents relating to the purchase of this products.

Blanco is committed to providing increasingly efficient products that are easy to use, respect the environment and are attractive and reliable.

**BLANCO**

# BLANCO

## *MODELS: PI5V*

# BLANCO

We ask that you carefully read the instructions within this booklet to enable you to obtain quality results from the outset.

The appliance must be installed only by an authorised person in compliance with the instructions provided. The manufacturer declines all responsibility for improper installation which may harm persons and animals and damage property.

The appliance must be used for the purpose for which it was expressly designed. Any other use (eg heating rooms) is considered to be improper and consequently dangerous. The manufacturer declines all responsibility for damage resulting from improper and irresponsible use.

The manufacturer shall not be held responsible for any inaccuracies in this handbook due to printing or transcription errors. The designs in the figures are purely indicative.

The manufacturer also reserves the right to make any modifications to the products as may be considered necessary, useful or in the interests of the user, without jeopardizing the main functional and safety features on the products themselves.

If your cooktop requires service, please contact your local customer service centre or your nearest Blanco agent listed at the back of this booklet.

COD. 04071GGB - 23.12.2009

# DESCRIPTION OF THE HOT PLATES

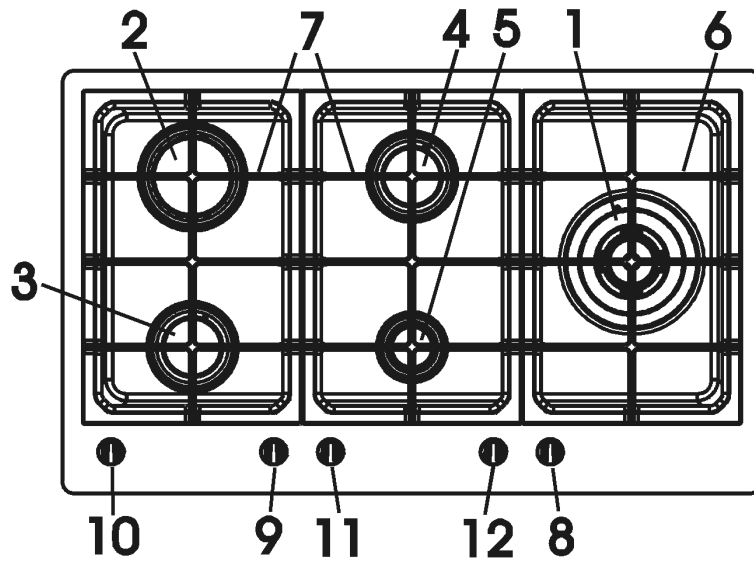

- 1 Ultra rapid gas burner
- 2 Rapid gas burner
- 3 Front semirapid gas burner
- 4 Back semirapid gas burner
- 5 Auxiliary gas burner
- 6 Enamelled steel pan support ultra rapid gas burner
- 7 Enamelled steel pan support 2F
- 8 Burner n° 1 control knob
- 9 Burner n° 2 control knob
- 10 Burner n° 3 control knob
- 11 Burner n° 4 control knob
- 12 Burner n° 5 control knob

	Natural	Propane
1	12.6 MJ/h	11.16 MJ/h
2	10.8 MJ/h	10.8 MJ/h
3	6.3 MJ/h	6.3 MJ/h
4	6.3 MJ/h	6.3 MJ/h
5	3.6 MJ/h	3.6 MJ/h

**Attention: this appliance has been manufactured for domestic use only and its employment by private person.**

# USE

## 1) BURNERS

A diagram is screen-printed above each knob on the front panel. This diagram indicates to which burner the knob in question corresponds. After having opened the gas mains or gas bottle tap, light the burners as described below:

### - manual ignition

Push and turn the knob corresponding to the required burner in an anticlockwise direction until it reaches the full on position (large flame fig. 1), then place a lighted match near the burner.

### - Electrical ignition

Push and turn the knob corresponding to the required burner in an anticlockwise direction until it reaches the full on position (large flame fig. 1), then depress and release the ignition button.

### - Automatic electrical ignition

Push and turn the knob corresponding to the required burner in an anticlockwise direction until it reaches the full on position (large flame fig. 1), then depress the knob.

### - Lighting burners equipped with flame failure device

The knobs of burners equipped with flame failure device must be turned in an anticlockwise direction until they reach the full on position (large flame fig. 1) and come to a stop. Now depress the knob in question and repeat the previously indicated operations.

Keep the knob depressed for about 10 seconds once the burner has ignited.

Should the flames accidentally go out, turn the burner control knob off and wait at least 1 min before attempting to light it again.

### HOW TO USE THE BURNERS

Bear in mind the following indications in order to achieve maximum efficiency with the least possible gas consumption:

- use adequate pans for each burner (consult the following table and fig. 2).
- When the pan comes to the boil, set the knob to the reduced rate position (small flame fig. 1).

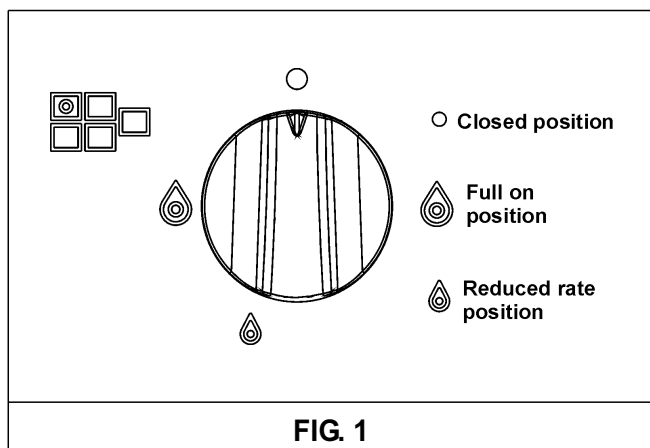

FIG. 1

- Always place a lid on the pans.
- Use only pan with a flat bottom.

Burners	Power ratings		Pan Ø in cm
	Natural	Propane	
Ultra rapid	12.6 MJ/h	11.16 MJ/h	24 ÷ 26
Rapid	10.8 MJ/h	10.8 MJ/h	20 ÷ 22
Semirapid red.	6.3 MJ/h	6.3 MJ/h	16 ÷ 18
Semirapid	6.3 MJ/h	6.3 MJ/h	16 ÷ 18
Auxiliary	3.6 MJ/h	3.6 MJ/h	10 ÷ 14

### WARNINGS:

- matches can be used to ignite the burners in a blackout.
- Never leave the appliance unattended when the burners are being used. Make sure there are no children in the near vicinity. Particularly make sure that the pan handles are correctly positioned and keep a check on foods requiring oil and grease to cook since these products can easily catch fire.
- The machine must not be used by people (including children) with impaired mental or physical capacities, or without experience of using electrical devices, unless supervised or instructed by an expert adult responsible for their care and safety. Children should not be allowed to play with the equipment.
- Never use aerosols near the appliance when it is operating.
- If the built-in hot plate has a lid, any spilt food should be immediately removed from this before it is opened. If the appliance has a glass lid, this could shatter when the hot plate becomes hot. Always switch off all the burners before closing the lid.
- Containers wider than the unit are recommended.

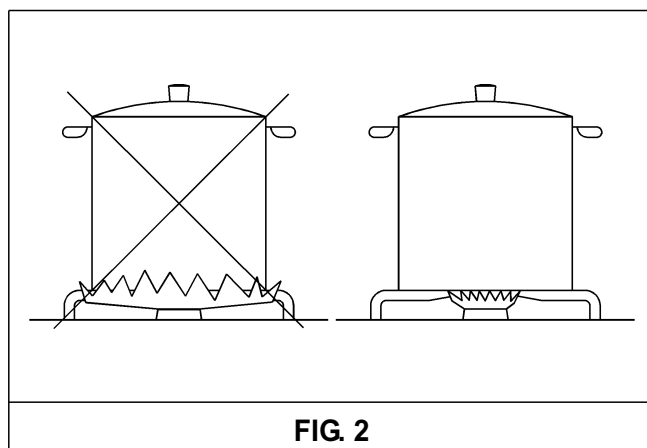

FIG. 2

# USE

**Notes:**

*use of a gas cooking appliance produces heat and moisture in the room in which it is installed. The room must therefore be well ventilated by keeping the natural air vents clear (fig. 3) and by activating the mechanical aeration device (suction hood or electric fan fig. 4 and fig. 5).*

*Intensive and lengthy use of the appliance may require additional ventilation. This can be achieved by opening a window or by increasing the power of the mechanical exhausting system if installed.*

**(\*) AIR INLET: SEE INSTALLATION CHAPTER**

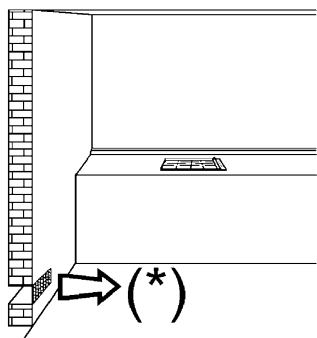

**FIG. 3**

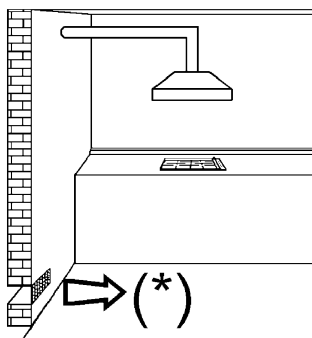

**FIG. 4**

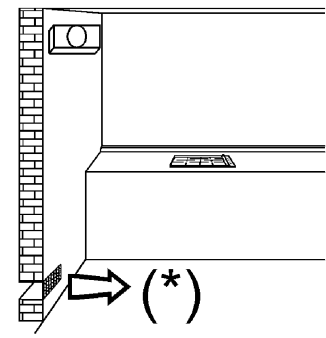

**FIG. 5**

# CLEANING

**IMPORTANT:**

*always disconnect the appliance from the gas and electricity mains before carrying out any cleaning operation.*

## 2) HOT PLATE

Periodically wash the hot plate, the enamelled steel pan support, the enamelled burner caps "C" and the burner heads "T" (see fig. 6) with lukewarm soapy water. Following this, all parts should be thoroughly rinsed and dried. Never wash them while they are still warm and never use abrasive powders. Do not allow vinegar, coffee, milk, salted water, lemon or tomato juice from remaining in contact with the enamelled surfaces for long periods of time.

**WARNINGS:**

*comply with the following instructions, before remounting the parts:*

*- check that burner head slots "T" (fig. 6) have not become clogged by foreign bodies.*

- *Check that enamelled burner cap "C" (fig. 6) have correctly positioned on the burner head. It must be steady.*
- *The exact position of the pan support is established by the rounded corners, which should be set towards the side edge of the hot plate.*
- *Do not force the taps if they are difficult open or close. Contact the technical assistance service for repairs.*
- *Don't use steam jets for the equipment cleaning.*

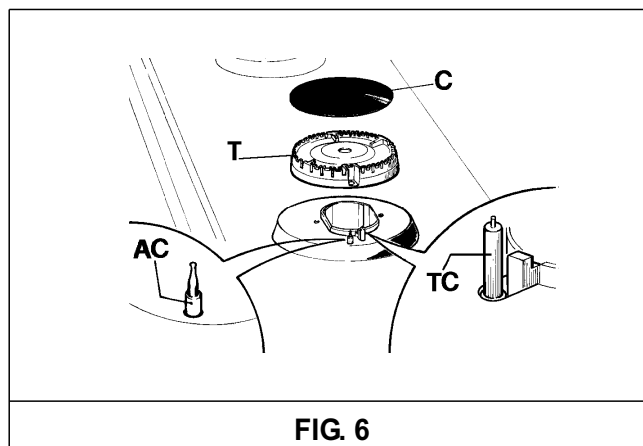

FIG. 6

# INSTALLATION

## TECHNICAL INFORMATION FOR THE INSTALLER

**Installation, adjustments of controls and maintenance must only be carried out by a qualified engineer.**

**Incorrect installation may cause damage to persons, animals or property for which the Manufacturer shall not be considered responsible. During the life of the system, the automatic safety or regulating devices on the appliance may only be modified by the manufacturer or by his duly authorized dealer.**

### 3) INSTALLING THE HOT PLATE

Check that the appliance is in a good condition after having removed the outer packaging and internal wrappings from around the various loose parts. In case of doubt, do not use the appliance and contact qualified personnel.

**Never leave the packaging materials (cardboard, bags, polystyrene foam, nails, etc.) within children's reach since they could become potential sources of danger.**

The measurements of the opening made in the top of the modular cabinet and into which the hot plate will be installed are indicated in either fig. 7. Always comply with the measurements given for the hole into which the appliance will be recessed (see fig. 7 and 8). The filotop model needs of a milling on the plan top of depth 3 mm, measures are shown in figures 10 of next page. It is advisable to spread on the milled surface a layer of "primer" anti-infiltration.

**The appliance belongs to class 3 and is therefore subject to all the provisions established by the provisions governing such appliances.**

### 4) FIXING THE HOT PLATE

The hot plate has a special seal which prevents liquid from getting into the cabinet. Strictly comply with the following instructions in order to correctly apply this seal:

- detach the seals from their backing, checking that the transparent protection still adheres to the seal itself.
- Overturn the hot plate and correctly position seal "E" (fig. 9) under the edge of the hot plate itself, so that the outer side of the seal perfectly matches the outer edge of the hot plate. The ends of the strips must fit together without overlapping.
- Evenly and securely fix the seal to the hot plate, pressing into place with the fingers and remove the strip of protective paper from the seal and set the plate into the hole made in the cabinet.
- To insert the hooks "G" into the fissures on the bottom and rotate them according to the arrow indications. To insert the screw "F" into the bottom holes and turn thoroughly the screws "H" on the hooks holes (see the sequence on the next page).
- In order to avoid accidental touch with the overheating bottom of the hob, during the working, is necessary to put a wooden insert, fixed by screws, at a minimum distance of 120 mm from the top (see fig. 7).
- To follow the installation measures shown in figures 10.

### COMPLY WITH THE DIMENSIONS (in mm)

	A	B	C	D	E
5F	835	495	52.5	52.5	60 min.

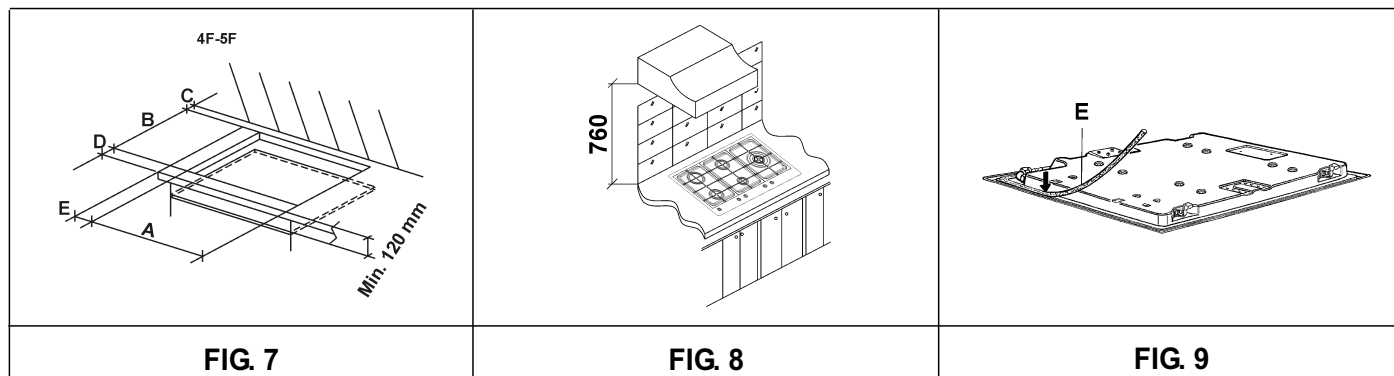

# INSTALLATION

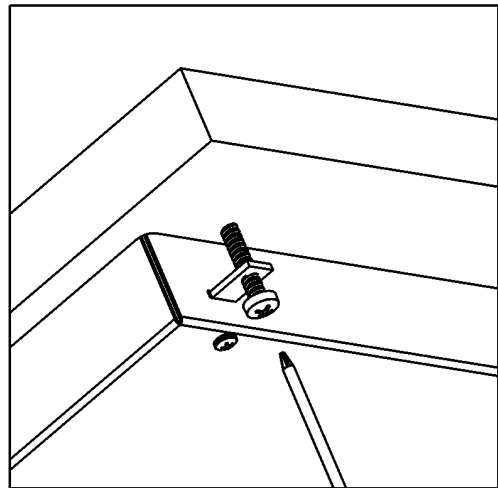
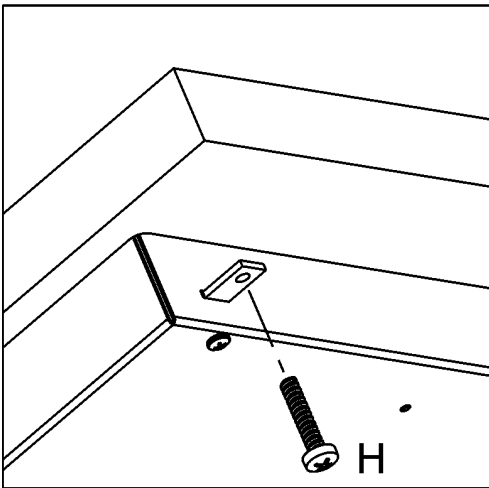
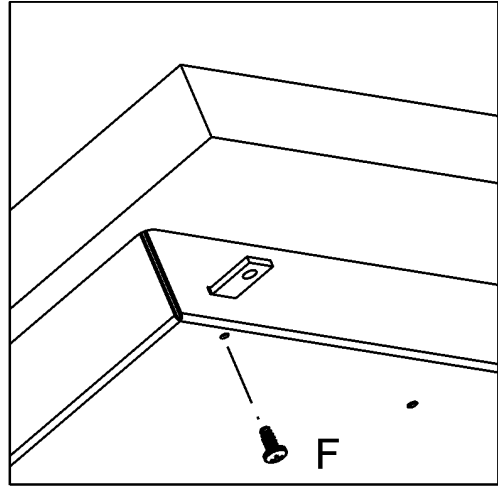
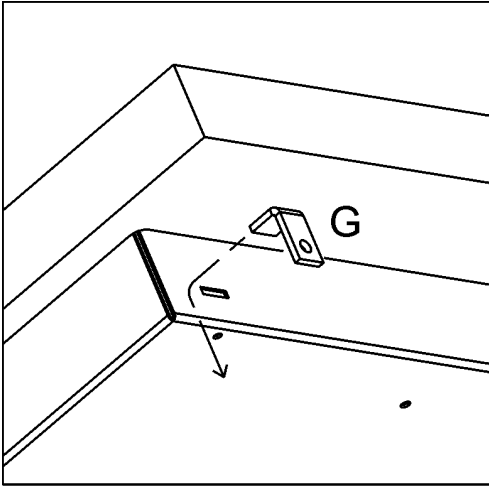

# INSTALLATION

## "FILOTOP" HOT PLATE INSTALLATION

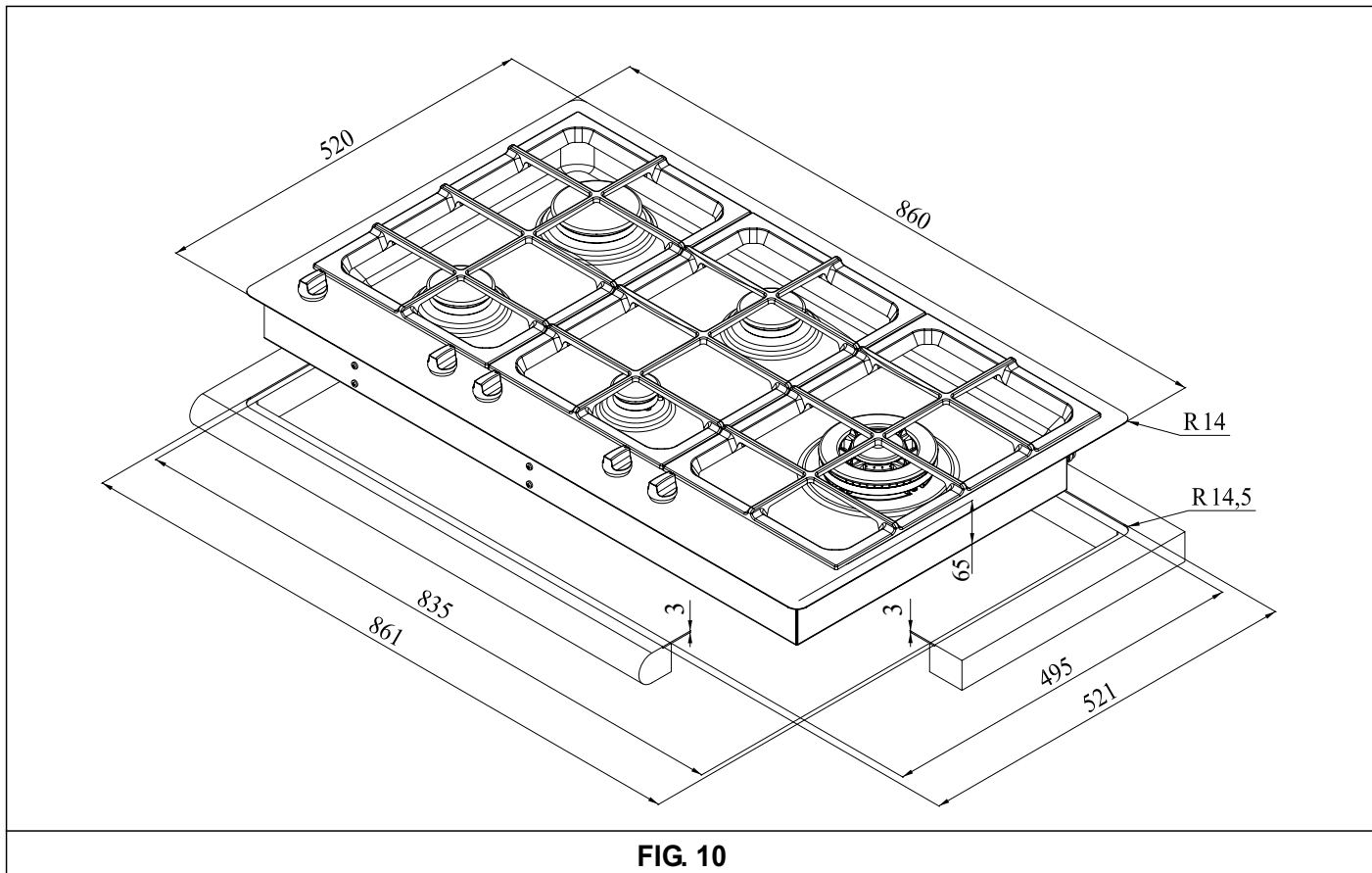

# INSTALLATION

## 5) GAS CONNECTION

The gas connection is located in the rear and on the underside of the appliance 100 mm from the right hand side.

There are two ways to carry out the connection to the main gas line:

**A.** The hotplate can be connected with rigid pipe as specified in AS5601 table 3.1.

**B.** If installing with a hose assembly, install with a hose assembly that complies with AS/ANZ 1869 (AGA Approved), 10mm ID, class B or D, no more than 1.2m long and in accordance with AS5601. Ensure that the hose does not contact the hot surfaces of the hotplate, oven, dishwasher or any other appliance that may be installed underneath or next to the hotplate. The hose should not be subjected to abrasion, kinking or permanent deformation and should be able to be inspected along its entire length with the cooktop in the installed position.

Unions compatible with the hose fittings must be used and all connections tested for gas leaks.

The gas supply connection for the hose assembly must be accessible.

### Natural Gas

Natural Gas installations require the connection of a gas regulator at the appliance. This regulator is supplied with the appliance on purchase.

Assemble the regulator (noting the gas flow direction) and transition pieces (supplied with the appliance), in accordance with figure 11.

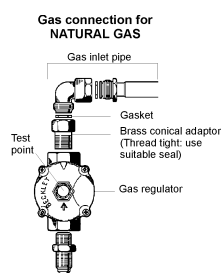

FIG. 11

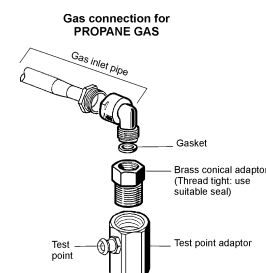

FIG. 12

The transition piece on the supply side of the regulator must be provided by the installer.

### Liquefied Petroleum Gas

In a Propane Gas installation the gas regulation is made at the gas cylinder and regulation at the appliance is not required. To connect supply to the appliance use transition pieces as shown in figure 12. These pieces are supplied with the appliance on purchase.

### WARNING:

**THE BURNER FLAME MUST BE ADJUSTED BY THE INSTALLER.**

**FAULTY INSTALLATION WILL NOT BE COVERED UNDER WARRANTY.**

## 6) ELECTRICAL CONNECTION

The appliance is supplied with a 1800 mm long flexible supply lead.

The point of attachment for this lead is located at the rear and on the underside of the appliance 380 mm from the right hand side.

The voltage and power consumption are detailed on the underside of the appliance. Ensure that the appliance is correctly rated to the supply.

Connect appliance by way of a switched power point.

### THE APPLIANCE MUST BE EARTHED

Ensure that this power point is properly earthed. Look at the connection wiring diagrams (fig. 13).

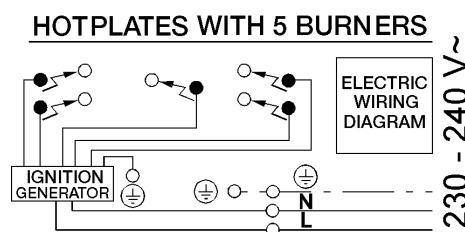

FIG. 13

# ADJUSTMENTS

**Always disconnect the appliance from the electricity main before making any adjustments. All seals must be replaced by the technician at the end of any adjustments or regulations. Our burners do not require primary air adjustment.**

## **a) Data Label**

The Data Label is located on the underside of the hotplate. A duplicate Data Label is supplied to adhere in an accessible area next to the hotplate. This hotplate is suitable for Natural Gas and Propane Gas; ensure that the available gas supply matches the Data Label.

## **b) Before Leaving**

Check that there are no gas leaks, but do not use a naked flame to detect gas leaks. Ignite all burners to ensure correct operation of gas valves, burners, ignition and if fitted, flame failure valves. Turn gas taps to low flame position and observe stability of the flame. When satisfied with the hotplate, please instruct the user on the correct method of operation. In case the appliance fails to operate correctly after all checks have been carried out, refer to the authorised service provider in your area.

## **7) TAPS**

Our taps are suitable for all gas, they are male conical type.

### **“Reduced rate” adjustment**

- Switch on the burner and turn the relative knob to the “Reduced rate” position (small flame fig. 1).
- Remove knob “M” (fig. 14) of the tap, which is simply pressed on to its rod.
- Insert a small screwdriver “D” into hole “C” (fig. 14) and turn the throttle screw to the right or left until the burner flame has been adequately regulated to the “Reduced rate” position.

Check that the flame does not go out when the knob is sharply switched from the “Full on” to the “Reduced rate” position.

***It is understood that only burners operating with Natural gas should be subjected to the above mentioned adjustments. The screw must be fully locked when the burners operate with Liquid gas.***

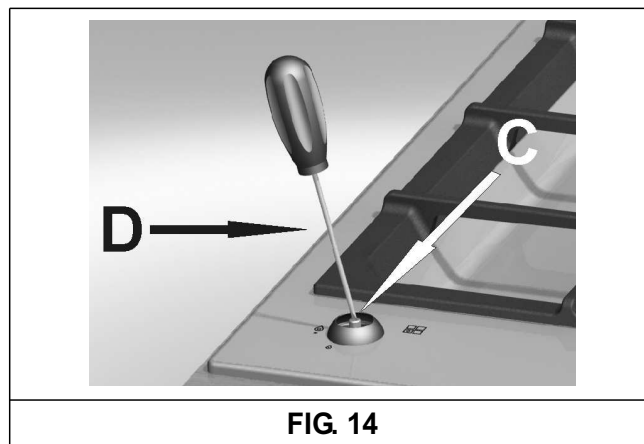

**FIG. 14**

# CONVERSIONS

## 8) PROPANE GAS TO NATURAL GAS CONVERSION PROCEDURE

Appliance models: Gas stainless steel hotplate models:

### PI5V 5 Burners

1. Remove each burner cap and burner skirt.
2. Remove the Propane Gas main injector with a 7 mm/VF tube spanner and replace with the appropriate size Natural Gas injector for each burner. The following injector sizes are required for Natural Gas:

<b>Burner</b>	<b>Main injector</b>
Wok	94 mm
Rapid	91 mm
Semi Rapid	70 mm
Semi Rapid	70 mm
Auxiliary	53 mm

3. Shut off gas supply to the appliance.
4. Disconnect gas inlet pipe from the Propane Gas test point inlet fitting.
5. Remove the Propane Gas test point inlet fitting from the appliance.
6. Fit the Natural Gas Regulator supplied in the conversion kit.
7. Connect the gas supply to the Regulator.
8. Check for gas leaks. Do not use a naked flame to check for gas leaks.
9. Adjust the gas pressure to 1.00 kPa.
10. Remove the control knob, with a thin shaft blade screwdriver down the centre of each gas valve shaft, screw the by-pass injector anti-clockwise. Test the appliance on both high and low flame for each burner. If the burner fails to remain alight or the flame is not stable on the simmer setting, adjust the by-pass screw, until flame is stable.
11. If not already removed, remove the "Only for use with Propane Gas" label adhered to the bottom panel near the gas connection.

## 9) NATURAL GAS TO PROPANE GAS CONVERSION PROCEDURE

Appliance models: Gas stainless steel hotplate models:

### PI5V 5 Burners

1. Remove each burner cap and burner skirt.
2. Remove the Natural Gas main injector with a 7 mm/VF tube spanner and replace with the appropriate size Propane Gas main injector for each burner. The following injector sizes are required for Propane Gas:

<b>Burner</b>	<b>Main injector</b>
Wok	176 mm
Rapid	155 mm
Semi Rapid	120 mm
Semi Rapid	120 mm
Auxiliary	90 mm

3. Remove the control knob, with a thin shaft blade screwdriver down the centre of each gas valve shaft, screw the by-pass injector fully clockwise.
4. Shut off gas supply to the appliance.
5. Disconnect gas inlet pipe from the Natural Gas Regulator.
6. Remove the Natural Gas Regulator from the appliance.
7. Fit the Propane Gas test point inlet fitting supplied in the conversion kit.
8. Connect the gas supply to the inlet fitting.
9. Check for gas leaks. Do not use a naked flame to check for gas leaks.
10. Adjust the gas pressure to 2.75 kPa.
11. Test the appliance on both high and low flame for each burner and check the gas pressure. If the burner fails to remain alight or the flame is not stable on the simmer setting, adjust the by-pass screw, until flame is stable.
12. If not already removed, remove the "Only for use with Natural Gas" label adhered to the bottom panel near the gas connection.

# CONVERSIONS

## 10) REPLACING THE INJECTORS

The burners can be adapted to different types of gas by mounting injectors suited to the type of gas in question. To do this, first remove the burner tops using a wrench "B". Now unscrew injector "A" (see fig. 15) and fit a injector corresponding to the utilized type of gas in its place.

It is advisable to strongly tighten the injector in place.

**After the injectors have been replaced, the burners must be regulated as explained in paragraphs 7. The technician must reset any**

**seals on the regulating or pre-regulating devices. The envelope with the injectors and the labels can be included in the kit, or at disposal to the authorized customer Service Centre.**

For the sake of convenience, the nominal rate table also lists the heat inputs of the burners, the diameter of the injectors and the working pressures of the various types of gas.

### BURNER ARRANGEMENT ON THE HOT PLATE

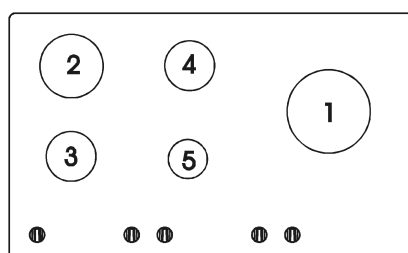

**TABLE 1**

BURNERS		GAS	NORMAL PRESSURE (kPa)	INJECTOR DIAMETER (1/100 mm)	NOMINAL HEAT INPUT ( MJ/h )
N°	DESCRIPTION				MAX.
1	ULTRA RAPID	PROPANE NATURAL	2.75 1.00	94 176	11.16 12.6
2	RAPID	PROPANE NATURAL	2.75 1.00	91 155	10.8 10.8
3	SEMI-RAPID	PROPANE NATURAL	2.75 1.00	70 120	6.3 6.3
4	SEMI-RAPID	PROPANE NATURAL	2.75 1.00	70 120	6.3 6.3
5	AUXILIARY	PROPANE NATURAL	2.75 1.00	53 90	3.6 3.6

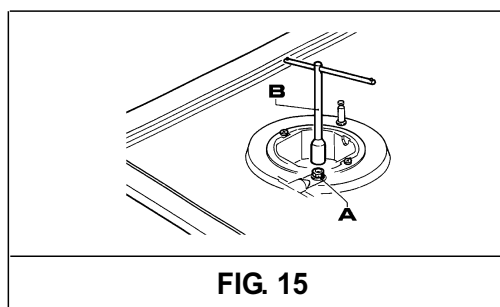

**FIG. 15**

# SERVICING

**Always disconnect the appliance from the electricity and gas mains before proceeding with any servicing operation.**

## 11) REPLACING HOT PLATE PARTS

When parts housed within the hot plate need replacing, it is first necessary to remove the hot plate itself from the cabinet, to overturn it, unscrew screws "V" and to remove part (see fig. 16) and the knobs fixed by pressure with the hands, in order to take off the appliance.

After having carried out the above listed operations, the burners (fig. 17), taps (fig. 18) and electrical components can all be replaced (fig. 19).

It is advisable to change seal "D" whenever a tap is replaced to ensure a perfect tightness.

## Greasing the taps (see fig. 20)

If a tap becomes stiff to operate, it must be immediately greased in compliance with the following instructions:

- remove the tap.
- Clean the cone and its housing using a cloth soaked in diluent.
- Lightly spread the cone with the relative grease.
- Fit the cone back in place, operate it several times and then remove it again. Eliminate any excess grease and check that the gas ducts have not become clogged.
- Fit all parts back in place, complying with the demounting order in reverse.
- Check the tightness by using soapy water. **The use of the flame is prohibited.**

To facilitate the servicing technician's task, here is a chart with the types and sections of the powering cables and the ratings of the electrical components.

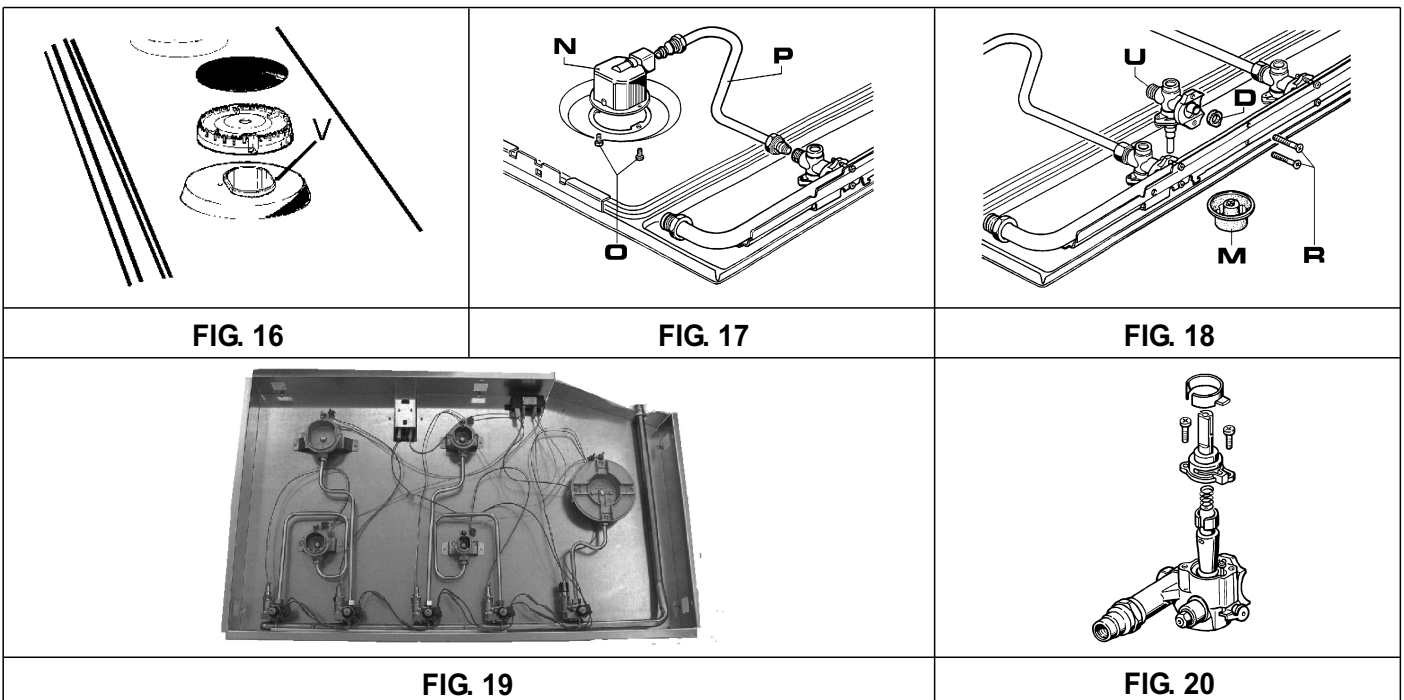

# SERVICING

## CABLE TYPES AND SECTIONS

TYPE OF HOT PLATE	TYPE OF CABLE	SINGLE - PHASE POWER SUPPLY
Gas hot plate	H05 RR - F	Section 3 x 0.75 mm <sup>2</sup>

**ATTENTION!!!**

*If the power supply cable is replaced, the installer should leave the ground wire longer than the phase conductors (fig. 21) and comply with the recommendations given in paragraph 6.*

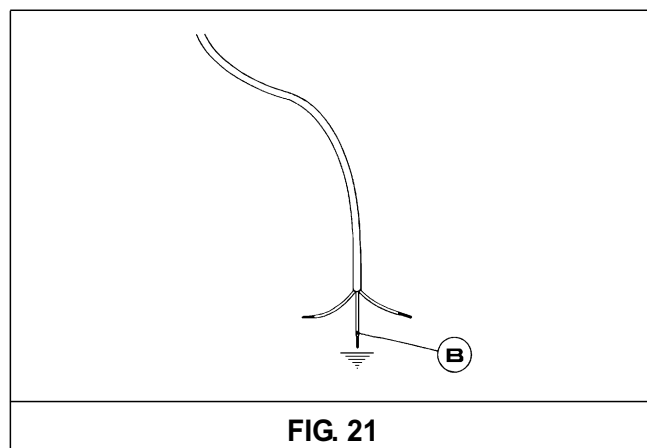

**FIG. 21**

# TECHNICAL ASSISTANCE AND SPARE PARTS

## MEA Contact Information.

### NEW SOUTH WALES

#### Head Office, Sales & Marketing Office

104 Vanessa Street  
Kingsgrove NSW 2208  
Telephone: 02 9503 2888  
Facsimile: 02 9503 2810

#### NSW Showroom\*

40 Ebley Street  
Bondi Junction NSW 2022  
Telephone: 02 9386 1190  
Facsimile: 02 9386 1671

#### Service and Spare Parts Metro

All General Whitegoods Service  
Telephone: 02 8788 8666  
Facsimile: 02 9756 1091

### AUSTRALIAN CAPITAL TERRITORY

#### Service and Spare Parts Metro

Detlevs Appliance & Electrical Care  
1/88 Sheppard Street  
Hume  
ACT 2905  
Telephone: 02 6260 1033  
Facsimile: 02 6260 1035

### VICTORIA

#### State Office and Showroom\*

35 Centre Road  
Scoresby VIC 3179  
Telephone: 03 8756 7888  
Facsimile: 03 8756 7907

#### Service and Spare Parts Metro

Advantage Appliances  
Telephone: 03 9874 4222  
Facsimile: 03 9874 6917

### QUEENSLAND

#### State Office and Showroom\*

148 Robinson Road - East  
Geebung  
QLD 4034  
Telephone: 07 3259 2555  
Facsimile: 07 3265 6933

#### Service and Spare Parts Metro

Endeavour Appliances  
Telephone: 07 3137 3633  
Facsimile: 07 3137 3663

#### Platinum Appliance Service

Telephone: 07 3862 1154  
Facsimile: 07 3862 1114

#### Roshad (Gold Coast)

Telephone: 07 5535 7044  
Facsimile: 07 5535 7407

### SOUTH AUSTRALIA & NORTHERN TERRITORY

#### Agent and Sales Office

S C Lighting & Electrical Supplies  
47 North Terrace  
Hackney SA 5069  
Telephone: 08 8362 4599  
Facsimile: 08 8362 4591

#### Service and Spare Parts Metro

Prestige Appliance Repair Centre  
Telephone: 08 8352 2022  
Facsimile: 08 8352 3044

### WESTERN AUSTRALIA

#### State Office

4/8 Ellen Stirling Boulevard.  
Innaloo  
WA 6018  
Telephone: 1300739033

#### Service and Spare Parts Metro

Metropolitan Appliance Repairs  
Telephone: 08 9330 1724  
Facsimile: 08 9317 1296

### TASMANIA

#### Agent and Sales Office

35 Centre Road  
Scoresby VIC 3179  
Telephone: 03 8756 7888  
Facsimile: 03 8756 7907

#### Service and Spare Parts

Electrical Equipment Service (Launceston)  
Telephone: 03 6339 3873  
Facsimile: 03 6339 4588

#### Baldocks Appliance Service (Hobart)

Telephone: 03 6234 5995  
Facsimile: 03 6234 8134

### MEA CUSTOMER SERVICE

# 1300 739 033

#### Website:

[www.meappliances.com.au](http://www.meappliances.com.au)  
[www.blanco-australia.com.au](http://www.blanco-australia.com.au)  
[www.dedietrich.com.au](http://www.dedietrich.com.au)

\* Contact Showrooms to confirm hours of business.

# WARRANTY SECTION

## BLANCO

### BLANCO COOKING PRODUCT WARRANTY

1. Subject to the "Statement of Standard Warranty Conditions" this product is covered by the following Warranty.

**TWO (2) YEARS WARRANTY from date of purchase, covering all parts and labour.**

2. The appliance is warranted under normal single family domestic installation and use, as set out in the instruction manual, against manufacturing defects for the Warranty periods shown above.

3. Should service be required under this Warranty, the purchaser should contact an approved BLANCO Service Provider during their normal business hours.

4. At no time does BLANCO/MEA have liability for any freight or transportation costs or for any damage during transit or for any consequence of failure of this appliance outside of the normal service area, unless such limitation of liability is prohibited by statute.

5. This Warranty excludes replacement of parts required due to normal wear and tear including light globes.

6. This Warranty only applies, provided the appliance has been used in accordance with the manufacturer's instructions and provided an accident, misuse, neglect or abuse has not damaged the appliance.

7. None of the above Warranties purport to exclude, restrict or modify either the application or the exercise of a right conferred by any applicable Statute.

8. Please complete the details below, which should be retained for future reference along with your proof of purchase:

**Date of Purchase:** .....

**Model No:** .....

**Serial No:** .....

#### Notice to Victorian Customers from the Victorian Plumbing Industry Commission.

This product must be installed by a licenced person as required by the Victorian Building Act 1993.

Only a licenced person will give you a Compliance Certificate, showing that the work complies with all the relevant standards. Only a licenced person will have insurance protecting their workmanship for 6 years. Make sure you use a licenced person to install this product and ask for your Compliance Certificate.

1. The Warranty only applies provided that the appliance has been used in accordance with the manufacturer's instructions and provided that the appliance has not been damaged by an accident, misuse, neglect or abuse of any person other than the manufacturer or BLANCO/Major Electrical Appliances ("MEA") or from faulty installation, mis-adjustment or tampering by unauthorised persons.

2. When a service inspection reveals the alleged fault or faults are caused by incorrect operation, contrary to the instruction manual, and otherwise the appliance is in good order and working condition, the purchaser shall be liable for a service fee charged by BLANCO/MEA or one of its' Service Providers.

3. If the appliance is used in Commercial Applications or for Rental purposes, a separate warranty of Twelve (12) months covering all parts with Three (3) months on the labour will apply.

4. Subject to the provisions of any applicable statute this Warranty applies to the original retail purchaser only and is not transferable.

5. Subject to the provisions of any applicable statute, at no time does BLANCO/MEA have liability for freight, transport or travel costs outside normal service areas.

6. None of the above Warranties purport to exclude, restrict or modify either the application or the exercise of a right conferred by any applicable statute.

7. Subject to any Warranties implied by statute, at no time will BLANCO/MEA or its' Service Providers be liable for any economic loss consequent upon the failure of the appliance.

8. This Warranty is only valid for major appliances imported and distributed by BLANCO/MEA, purchased and used in Australia.

**MEA0304**